

EEDi-5273 Drug-Drug Interaction Profile: A Technical Guide

Author: BenchChem Technical Support Team. **Date:** April 2026

Compound of Interest

Compound Name: EEDi-5273

Cat. No.: B10861843

[Get Quote](#)

SUZHOU, China, and ROCKVILLE, Md., December 8, 2025 — This technical support guide provides researchers, scientists, and drug development professionals with a comprehensive overview of the drug-drug interaction (DDI) profile of **EEDi-5273** (also known as APG-5918), an investigational, potent, and orally bioavailable small-molecule inhibitor of the Embryonic Ectoderm Development (EED) protein. Preclinical data indicate a low potential for **EEDi-5273** to cause clinically significant drug-drug interactions mediated by cytochrome P450 (CYP) enzymes.

Frequently Asked Questions (FAQs)

Q1: What is the potential for **EEDi-5273** to inhibit or induce cytochrome P450 (CYP) enzymes?

A1: Preclinical studies have demonstrated that **EEDi-5273** has a low risk of engaging in drug-drug interactions mediated by CYP enzymes.^{[1][2][3][4][5]} In these in vitro studies, **EEDi-5273** did not show significant inhibitory or inductive activity towards major CYP isoforms at clinically relevant concentrations.^{[1][2][3][4][5]}

Q2: Has the effect of **EEDi-5273** been tested on specific CYP450 enzymes?

A2: Yes, the inhibitory potential of **EEDi-5273** against a panel of key human CYP450 enzymes has been evaluated. The results, summarized in the table below, show weak inhibition with IC50 values largely considered to be outside the range of clinical significance.

Q3: What do the IC50 values for CYP inhibition indicate?

A3: The IC50 value is the concentration of a drug that is required to inhibit the activity of an enzyme by 50%. Higher IC50 values are indicative of weaker inhibition. The preclinical data for **EEDi-5273** suggest that high concentrations of the drug would be needed to cause significant inhibition of CYP enzymes, reducing the likelihood of DDIs when co-administered with other drugs that are metabolized by these enzymes.

Q4: Is there any information on the potential for **EEDi-5273** to interact with drug transporters like P-glycoprotein (P-gp)?

A4: Currently, there is limited publicly available information regarding the interaction of **EEDi-5273** with drug transporters such as P-glycoprotein (P-gp). Further studies are likely required to fully characterize the potential for transporter-mediated drug interactions.

Troubleshooting Guide for In Vitro DDI Experiments

Issue 1: Observing higher than expected CYP inhibition in an in vitro assay.

- Possible Cause 1: Experimental Conditions. Ensure that the concentration of **EEDi-5273** used in the assay is appropriate and that the incubation times and protein concentrations are consistent with established protocols.
- Possible Cause 2: Solvent Effects. Verify that the final concentration of the solvent (e.g., DMSO) used to dissolve **EEDi-5273** is not affecting enzyme activity. A solvent control group is crucial.
- Possible Cause 3: Non-specific Binding. **EEDi-5273** may bind non-specifically to labware or other components in the assay mixture. Consider using low-binding plates and tubes.

Issue 2: Difficulty in interpreting CYP induction assay results.

- Possible Cause 1: Cytotoxicity. High concentrations of **EEDi-5273** may cause cytotoxicity in the hepatocytes, leading to a decrease in mRNA expression that could be misinterpreted as a lack of induction. Assess cell viability concurrently.
- Possible Cause 2: Sub-optimal Inducer Concentration. Ensure that the positive control inducers for each CYP isoform are used at concentrations known to elicit a robust response.

Data on Cytochrome P450 Inhibition

The following table summarizes the in vitro inhibitory potential of **EEDi-5273** against major human cytochrome P450 enzymes.

CYP Isozyme	% Inhibition	IC50 (µM)
CYP1A2	>30	>30
CYP2B6	>30	>30
CYP2C9	8.8	>30
CYP2C19	17.9	>30
CYP2D6	14.3	>30
CYP3A4	>30	>30

Data from in vitro preclinical studies.

Experimental Protocols

Cytochrome P450 Inhibition Assay (IC50 Determination)

The potential for **EEDi-5273** to inhibit major human CYP enzymes (CYP1A2, CYP2B6, CYP2C9, CYP2C19, CYP2D6, and CYP3A4) was assessed using human liver microsomes.

- Incubation: Human liver microsomes were incubated with a range of concentrations of **EEDi-5273** and a specific probe substrate for each CYP isoform.
- Reaction Initiation: The metabolic reaction was initiated by the addition of an NADPH-regenerating system.

- **Metabolite Quantification:** Following a specific incubation period, the reaction was terminated, and the formation of the specific metabolite was quantified using liquid chromatography-tandem mass spectrometry (LC-MS/MS).
- **IC50 Calculation:** The concentration of **EEDi-5273** that caused a 50% reduction in the rate of metabolite formation (IC50) was determined by non-linear regression analysis of the concentration-response curve.

Cytochrome P450 Induction Assay

The potential for **EEDi-5273** to induce the expression of CYP1A2, CYP2B6, and CYP3A4 was evaluated in cultured human hepatocytes.

- **Cell Treatment:** Human hepatocytes were treated with **EEDi-5273** at various concentrations for a period of 48 to 72 hours. Positive control inducers were used in parallel.
- **mRNA Quantification:** After the treatment period, total RNA was isolated from the hepatocytes, and the relative mRNA levels of the target CYP genes were quantified using quantitative real-time polymerase chain reaction (qRT-PCR).
- **Data Analysis:** The fold-change in CYP mRNA expression in **EEDi-5273**-treated cells was compared to that in vehicle-treated cells to determine the induction potential.

Visualizations

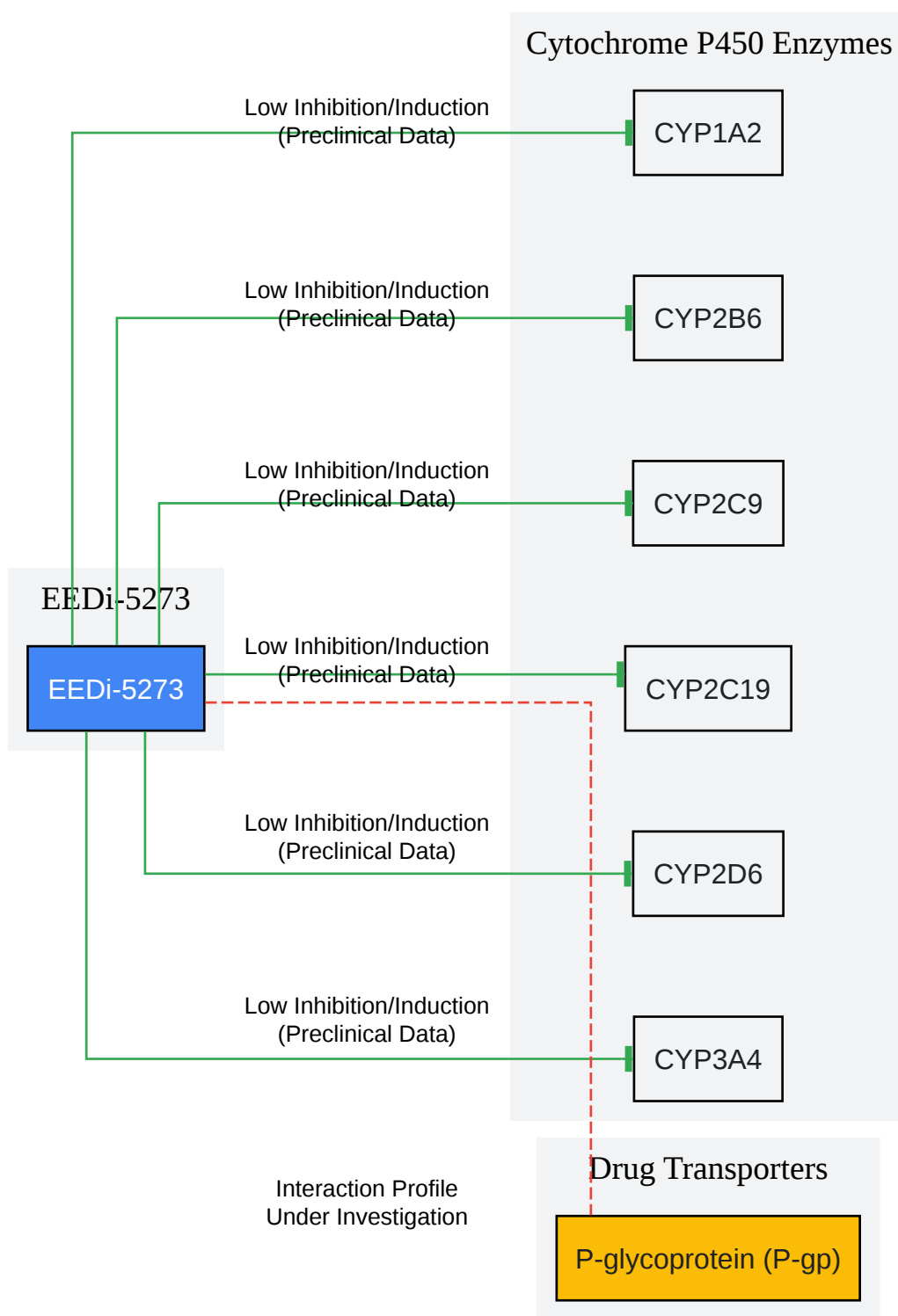

[Click to download full resolution via product page](#)

Caption: Overview of **EEDi-5273**'s drug-drug interaction profile.

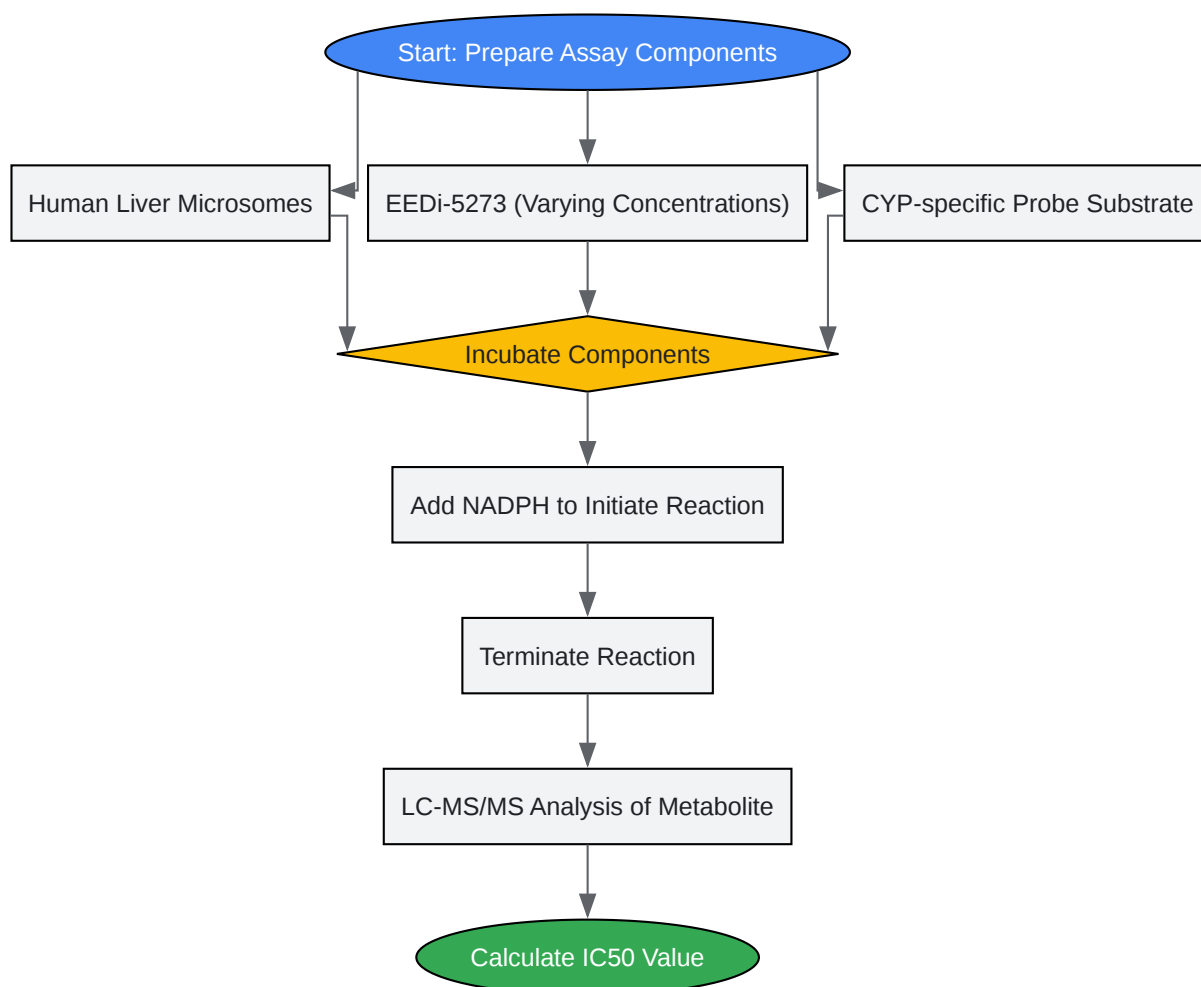

[Click to download full resolution via product page](#)

Caption: Experimental workflow for CYP450 inhibition assay.

Need Custom Synthesis?

BenchChem offers custom synthesis for rare earth carbides and specific isotopic labeling.

Email: info@benchchem.com or [Request Quote Online](#).

References

- [1. Discovery of EEDi-5273 as an Exceptionally Potent and Orally Efficacious EED Inhibitor Capable of Achieving Complete and Persistent Tumor Regression - PMC \[pmc.ncbi.nlm.nih.gov\]](#)
- [2. drugdiscovery.umich.edu \[drugdiscovery.umich.edu\]](#)
- [3. JMC Publishes Study Showing Potential of EED Inhibitor EEDi-5273 - \[ascentage.com\]](#)
- [4. Assessing Cytochrome P450 Time-Dependent Inhibition \(IC50 Shift Assay\) Using Both Diluted and Non-Diluted Methods | Springer Nature Experiments \[experiments.springernature.com\]](#)
- [5. biospace.com \[biospace.com\]](#)
- To cite this document: BenchChem. [EEDi-5273 Drug-Drug Interaction Profile: A Technical Guide]. BenchChem, [2026]. [Online PDF]. Available at: [\[https://www.benchchem.com/product/b10861843/docs#eedi-5273-drug-drug-interaction-profile-a-technical-guide\]](https://www.benchchem.com/product/b10861843/docs#eedi-5273-drug-drug-interaction-profile-a-technical-guide)

Disclaimer & Data Validity:

The information provided in this document is for Research Use Only (RUO) and is strictly not intended for diagnostic or therapeutic procedures. While BenchChem strives to provide accurate protocols, we make no warranties, express or implied, regarding the fitness of this product for every specific experimental setup.

Technical Support: The protocols provided are for reference purposes. Unsure if this reagent suits your experiment?

Need Industrial/Bulk Grade? [Request Custom Synthesis Quote](#)

BenchChem

Our mission is to be the trusted global source of essential and advanced chemicals, empowering scientists and researchers to drive progress in science and industry.

Contact

Address: 3281 E Guasti Rd

Ontario, CA 91761, United States

Phone: (601) 213-4426

Email: info@benchchem.com

[Contact our Ph.D. Support Team for a compatibility check](#)