

# Comparative In Vitro Analysis of DAPT and Begacestat: A Guide for Researchers

**Author:** BenchChem Technical Support Team. **Date:** April 2026

## Compound of Interest

Compound Name: *Dapt*  
Cat. No.: *B10861383*

[Get Quote](#)

For researchers, scientists, and drug development professionals, this guide provides an objective in vitro comparison of two prominent gamma-secretase inhibitors: DAPT and Begacestat. This analysis is supported by experimental data on their potency and selectivity, alongside detailed protocols for key assays.

Gamma-secretase is a critical enzyme in the amyloidogenic processing of amyloid precursor protein (APP), which leads to the production of amyloid-beta ( $A\beta$ ) peptides. The accumulation of  $A\beta$ , particularly the  $A\beta_{42}$  isoform, is a central event in the pathogenesis of Alzheimer's disease. Consequently, inhibiting gamma-secretase to reduce  $A\beta$  production has been a major focus of therapeutic development. However, gamma-secretase also cleaves other substrates, most notably the Notch receptor, which is essential for normal cell signaling. Inhibition of Notch signaling is associated with significant adverse effects, making substrate selectivity a key challenge in the development of gamma-secretase inhibitors.

This guide focuses on the in vitro characteristics of two well-studied gamma-secretase inhibitors: DAPT (N-[N-(3,5-Difluorophenacetyl)-L-alanyl]-S-phenylglycine t-butyl ester) and Begacestat (GSI-953).

## Data Presentation: In Vitro Efficacy and Selectivity

The following tables summarize the quantitative data on the in vitro potency and selectivity of DAPT and Begacestat. It is important to note that the experimental conditions, such as cell lines and assay formats, can influence the observed IC50/EC50 values.

Compound	Assay Type	Target	IC50/EC50 (nM)	Cell Line/System
DAPT	Cellular	Total A $\beta$	115	Human Primary Neuronal Cultures
Cellular	A $\beta$ 42	200	Human Primary Neuronal Cultures	
Cellular	Notch Signaling	160	OVCAR-3	
Begacestat	Cellular	A $\beta$ 40	14.8[1]	Cellular Assay
Cellular	A $\beta$ 42	12.4[1]	Cellular Assay	
Cellular	APP vs. Notch Selectivity	~16-fold	Cellular Assay[2]	

Table 1: In Vitro Potency of DAPT and Begacestat. This table provides a summary of the half-maximal inhibitory/effective concentrations for each compound against A $\beta$  production and Notch signaling.

## Mandatory Visualization

### Signaling Pathways and Experimental Workflow

To visually represent the mechanisms of action and experimental procedures, the following diagrams have been generated using the DOT language.

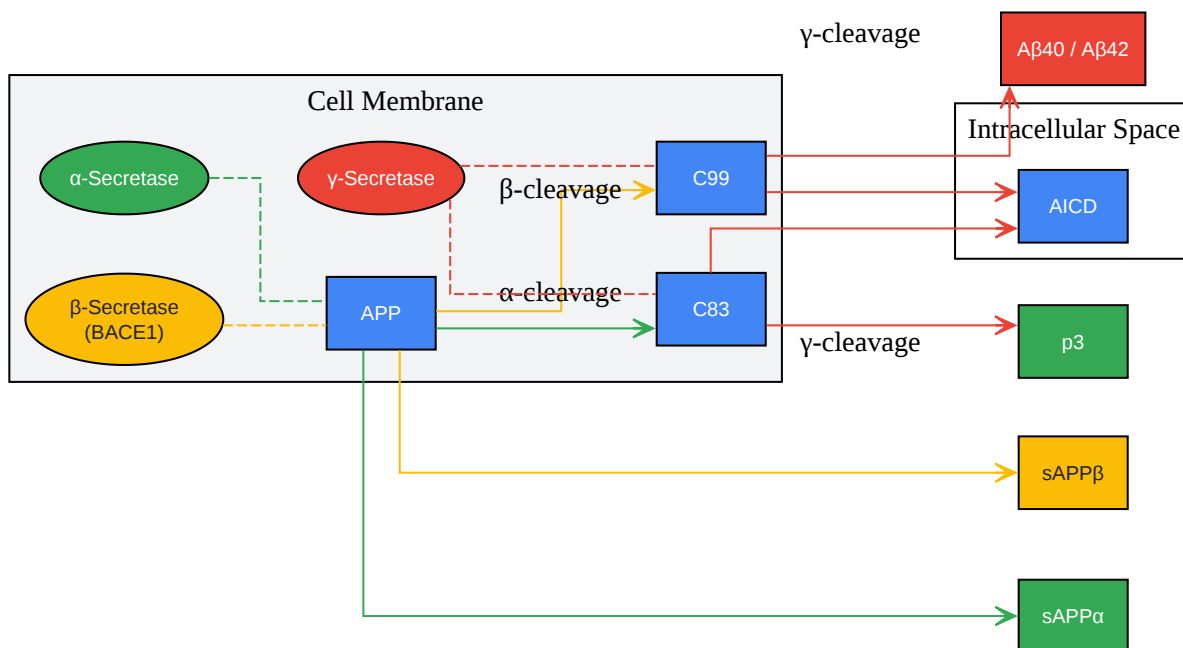

[Click to download full resolution via product page](#)

Caption: Amyloid Precursor Protein (APP) Processing Pathways.

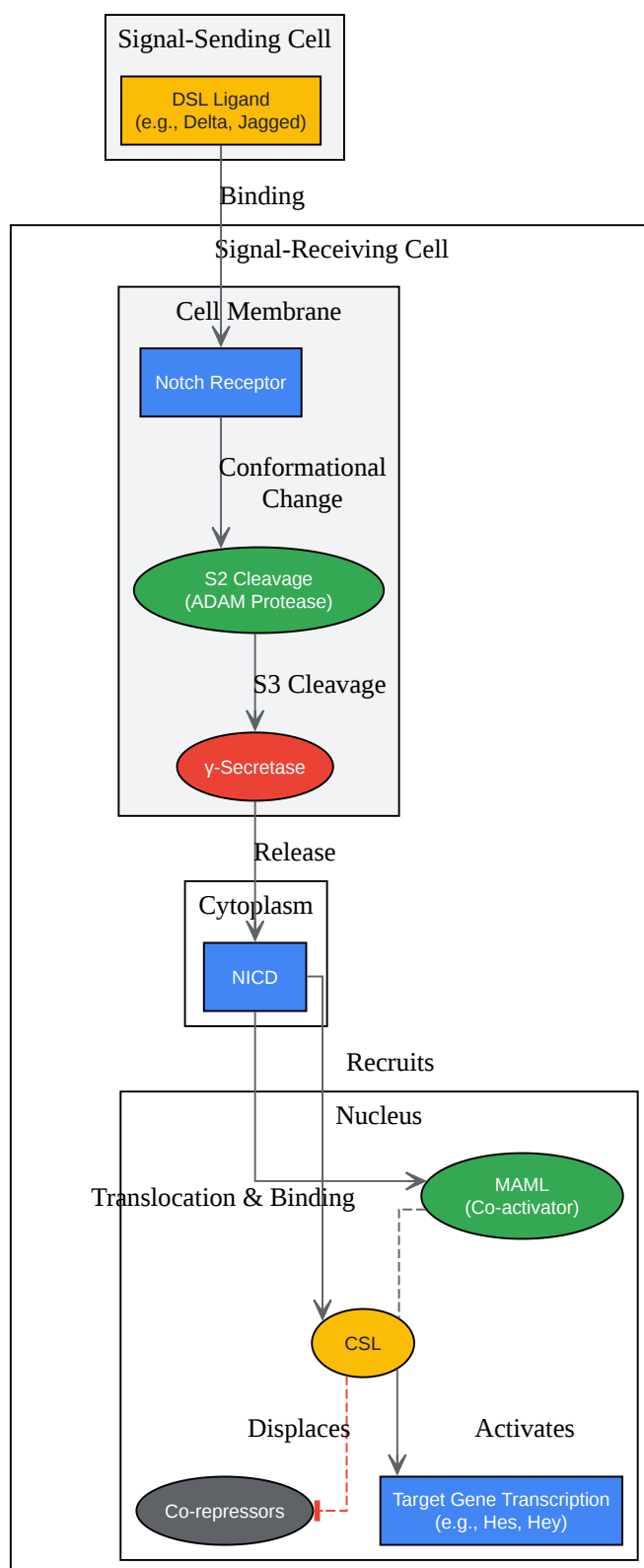

[Click to download full resolution via product page](#)

Caption: The  $\gamma$ -Secretase Dependent Notch Signaling Pathway.

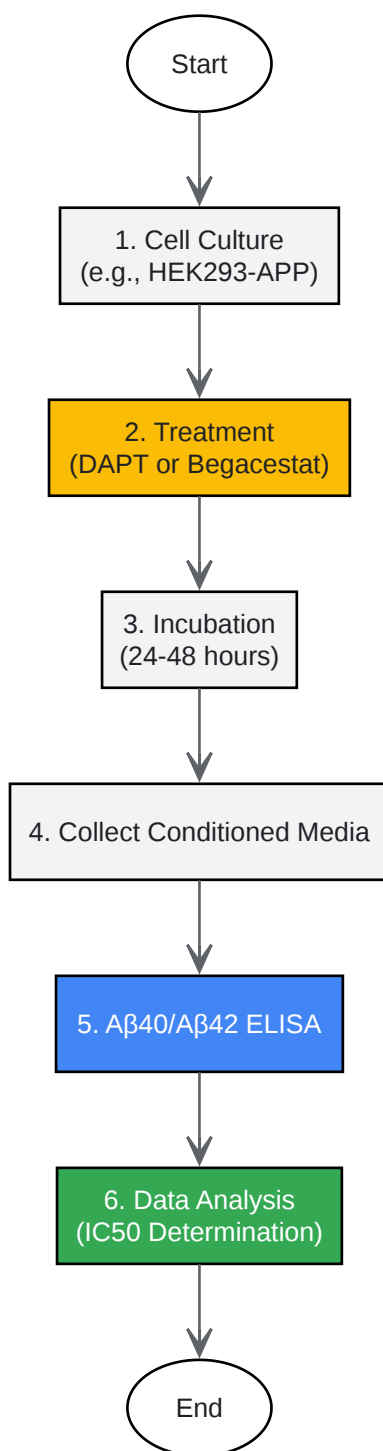

[Click to download full resolution via product page](#)

Caption: Workflow for Cell-Based Aβ Quantification Assay.

## Experimental Protocols

## Cell-Based A $\beta$ Quantification Assay (ELISA)

This assay quantifies the amount of A $\beta$ 40 and A $\beta$ 42 secreted from cells treated with a gamma-secretase inhibitor.

Materials:

- HEK293 cells stably overexpressing human APP (or other suitable cell line)
- Dulbecco's Modified Eagle Medium (DMEM)
- Fetal Bovine Serum (FBS)
- Penicillin-Streptomycin
- DAPT and Begacestat
- Dimethyl sulfoxide (DMSO)
- Phosphate-Buffered Saline (PBS)
- A $\beta$ 40 and A $\beta$ 42 ELISA kits
- 96-well cell culture plates
- Microplate reader

Procedure:

- **Cell Seeding:** Seed HEK293-APP cells into 96-well plates at a suitable density and allow them to adhere overnight in a humidified incubator at 37°C with 5% CO<sub>2</sub>.
- **Compound Preparation:** Prepare stock solutions of DAPT and Begacestat in DMSO. Serially dilute the compounds in cell culture medium to achieve a range of final concentrations. Include a vehicle control (DMSO alone).
- **Cell Treatment:** Remove the existing medium from the cells and replace it with the medium containing the various concentrations of the test compounds or vehicle control.

- Incubation: Incubate the treated cells for 24-48 hours at 37°C with 5% CO<sub>2</sub>.
- Sample Collection: After incubation, collect the conditioned medium from each well.
- ELISA: Perform the A $\beta$ 40 and A $\beta$ 42 ELISAs on the collected conditioned media according to the manufacturer's instructions.[\[3\]](#)[\[4\]](#)[\[5\]](#)[\[6\]](#)
- Data Analysis: Measure the absorbance using a microplate reader. Generate a standard curve for A $\beta$ 40 and A $\beta$ 42 to determine the concentration of A $\beta$  in each sample. Calculate the percentage of inhibition for each compound concentration relative to the vehicle control. Determine the IC<sub>50</sub> value by plotting the percentage of inhibition against the compound concentration and fitting the data to a dose-response curve.

## Notch Signaling Inhibition Assay (Luciferase Reporter Assay)

This assay measures the inhibition of Notch signaling by quantifying the activity of a reporter gene (luciferase) under the control of a Notch-responsive promoter.[\[7\]](#)[\[8\]](#)[\[9\]](#)[\[10\]](#)[\[11\]](#)[\[12\]](#)

### Materials:

- HEK293 cells stably co-transfected with a Notch receptor construct and a luciferase reporter construct under the control of a CSL-responsive promoter.
- Cell culture medium and supplements.
- DAPT and Begacestat.
- DMSO.
- 96-well white, clear-bottom cell culture plates.
- Luciferase assay reagent.
- Luminometer.

### Procedure:

- Cell Seeding: Seed the reporter cell line into 96-well white, clear-bottom plates and allow them to adhere overnight.
- Compound Preparation: Prepare serial dilutions of DAPT and Begacestat in cell culture medium. Include a vehicle control.
- Cell Treatment: Treat the cells with the compounds or vehicle and incubate for 24 hours.[7]
- Luciferase Assay: After incubation, lyse the cells and measure luciferase activity using a luminometer according to the manufacturer's protocol for the luciferase assay system.[10]
- Data Analysis: Normalize the luciferase signal to a co-transfected control reporter (e.g., Renilla luciferase) or to total protein concentration to account for differences in cell number. Calculate the percentage of inhibition of Notch signaling for each compound concentration relative to the vehicle control. Determine the IC50 value from the dose-response curve.

## Comparative Analysis

Based on the available in vitro data, Begacestat demonstrates significantly higher potency in inhibiting the production of both A $\beta$ 40 and A $\beta$ 42 compared to DAPT.[1] The EC50 values for Begacestat are in the low nanomolar range, while the IC50 values for DAPT are in the mid-to-high nanomolar range for A $\beta$  inhibition.

Furthermore, Begacestat exhibits notable selectivity for inhibiting APP processing over Notch signaling, with a reported selectivity of approximately 16-fold.[2] This is a crucial characteristic, as off-target inhibition of Notch signaling can lead to toxicity. While a direct selectivity ratio for DAPT is not consistently reported in the same manner, the similar IC50 values for A $\beta$  and Notch inhibition suggest a lower selectivity profile compared to Begacestat.

In conclusion, the in vitro data presented in this guide suggests that Begacestat is a more potent and selective inhibitor of gamma-secretase for the reduction of A $\beta$  peptides compared to DAPT. These findings highlight the importance of considering both potency and selectivity in the development of gamma-secretase inhibitors for therapeutic applications. The provided experimental protocols offer a framework for researchers to conduct their own comparative studies and further investigate the properties of these and other gamma-secretase inhibitors.

### Need Custom Synthesis?

BenchChem offers custom synthesis for rare earth carbides and specific isotopic labeling.

Email: [info@benchchem.com](mailto:info@benchchem.com) or [Request Quote Online](#).

## References

- 1. ACS Chemical Neuroscience Molecule Spotlight on Begacestat (GSI-953) - PMC [[pubmed.ncbi.nlm.nih.gov](https://pubmed.ncbi.nlm.nih.gov)]
- 2. Begacestat (GSI-953): a novel, selective thiophene sulfonamide inhibitor of amyloid precursor protein gamma-secretase for the treatment of Alzheimer's disease - PubMed [[pubmed.ncbi.nlm.nih.gov](https://pubmed.ncbi.nlm.nih.gov)]
- 3. [benchchem.com](https://www.benchchem.com) [[benchchem.com](https://www.benchchem.com)]
- 4. Key considerations for ELISA-based quantification of diverse amyloid beta forms in murine brain homogenates - PMC [[pubmed.ncbi.nlm.nih.gov](https://pubmed.ncbi.nlm.nih.gov)]
- 5. [novamedline.com](https://www.novamedline.com) [[novamedline.com](https://www.novamedline.com)]
- 6. [researchgate.net](https://www.researchgate.net) [[researchgate.net](https://www.researchgate.net)]
- 7. [bpsbioscience.com](https://www.bpsbioscience.com) [[bpsbioscience.com](https://www.bpsbioscience.com)]
- 8. [bpsbioscience.com](https://www.bpsbioscience.com) [[bpsbioscience.com](https://www.bpsbioscience.com)]
- 9. [resources.amsbio.com](https://www.resources.amsbio.com) [[resources.amsbio.com](https://www.resources.amsbio.com)]
- 10. [med.emory.edu](https://www.med.emory.edu) [[med.emory.edu](https://www.med.emory.edu)]
- 11. Real-time imaging of Notch activation using a Luciferase Complementation-based Reporter - PMC [[pubmed.ncbi.nlm.nih.gov](https://pubmed.ncbi.nlm.nih.gov)]
- 12. [Establishment of in vitro and cell-based drug screening model for Notch signaling pathway] - PubMed [[pubmed.ncbi.nlm.nih.gov](https://pubmed.ncbi.nlm.nih.gov)]
- To cite this document: BenchChem. [Comparative In Vitro Analysis of DAPT and Begacestat: A Guide for Researchers]. BenchChem, [2026]. [Online PDF]. Available at: [<https://www.benchchem.com/product/b10861383/docs#comparative-in-vitro-analysis-of-dapt-and-begacestat-a-guide-for-researchers>]

---

### Disclaimer & Data Validity:

The information provided in this document is for Research Use Only (RUO) and is strictly not intended for diagnostic or therapeutic procedures. While BenchChem strives to provide accurate protocols, we make no warranties, express or implied, regarding the fitness of this product for every specific experimental setup.

**Technical Support:** The protocols provided are for reference purposes. Unsure if this reagent suits your experiment?

**Need Industrial/Bulk Grade?** [Request Custom Synthesis Quote](#)

## BenchChem

Our mission is to be the trusted global source of essential and advanced chemicals, empowering scientists and researchers to drive progress in science and industry.

### Contact

Address: 3281 E Guasti Rd  
Ontario, CA 91761, United States  
Phone: (601) 213-4426  
Email: [info@benchchem.com](mailto:info@benchchem.com)

[Contact our Ph.D. Support Team for a compatibility check](#)