

Application Notes and Protocols for PDZ1i Combination Therapy Experimental Design

Author: BenchChem Technical Support Team. **Date:** April 2026

Compound of Interest

Compound Name: PDZ1i
Cat. No.: B10861142

[Get Quote](#)

For Researchers, Scientists, and Drug Development Professionals

Introduction

Metastasis is the primary cause of mortality in cancer patients, making the identification of novel therapeutic targets that regulate this process a critical area of research. Melanoma Differentiation-Associated Gene 9/Syntenin (MDA-9/Syntenin), a scaffolding protein containing two PDZ domains, has emerged as a key driver of metastasis in a variety of cancers, including glioblastoma, melanoma, and breast cancer.[1][2][3][4] MDA-9/Syntenin facilitates the assembly of signaling complexes that promote tumor cell invasion, angiogenesis, and immune evasion.[2] The small molecule inhibitor, **PDZ1i**, targets the first PDZ domain of MDA-9/Syntenin, disrupting its protein-protein interactions and subsequent downstream signaling. Preclinical studies have demonstrated that **PDZ1i** can inhibit cancer cell invasion and metastasis. Furthermore, combining **PDZ1i** with standard-of-care therapies such as radiation has shown promise in enhancing anti-tumor efficacy, particularly in aggressive cancers like glioblastoma.

These application notes provide a comprehensive guide for designing and conducting preclinical experiments to evaluate **PDZ1i** in combination with other anti-cancer agents.

Detailed protocols for key in vitro and in vivo assays are provided to enable researchers to assess the synergistic or additive effects of **PDZ1i** combination therapies.

Rationale for Combination Therapy

The multifaceted role of MDA-9/Syntenin in promoting cancer progression makes it an attractive target for combination therapies. By inhibiting MDA-9/Syntenin with **PDZ1i**, cancer cells can be sensitized to the cytotoxic effects of other treatments. For instance, in glioblastoma, **PDZ1i** has been shown to radiosensitize tumor cells, leading to improved survival in animal models when combined with radiation therapy. The proposed mechanisms for this synergy include the inhibition of radiation-induced invasion and the disruption of key survival signaling pathways. Additionally, **PDZ1i**'s ability to modulate the tumor microenvironment and immune response suggests its potential for combination with immunotherapies, such as immune checkpoint inhibitors.

Key Signaling Pathways

MDA-9/Syntenin acts as a central hub for several pro-tumorigenic signaling pathways. Understanding these pathways is crucial for designing rational combination therapies and for interpreting experimental results.

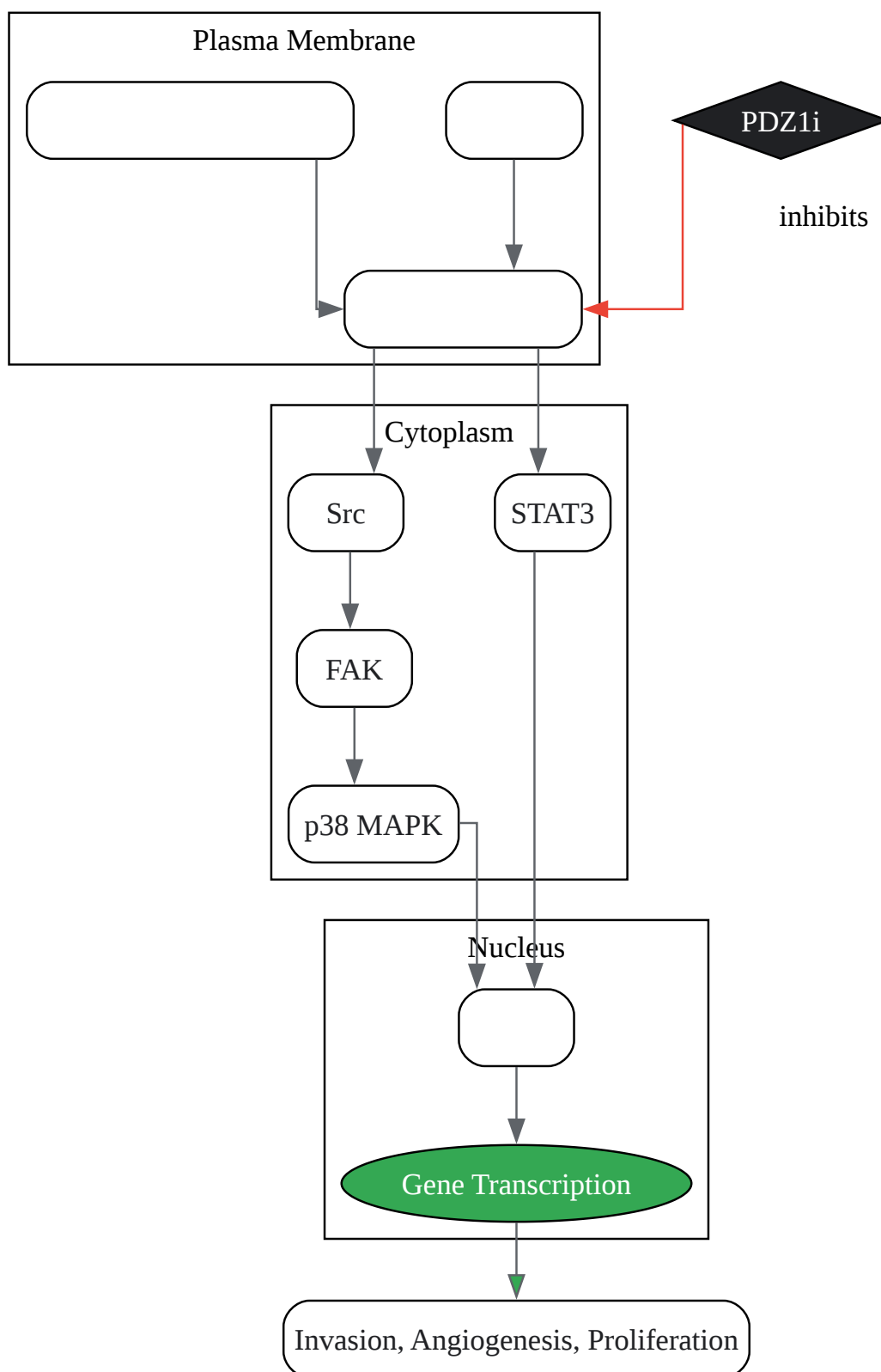

[Click to download full resolution via product page](#)

Figure 1: Simplified MDA-9/Syntenin Signaling Pathway and **PDZ1i** Inhibition.

Data Presentation

In Vitro Efficacy of PDZ1i

The following table summarizes representative data on the in vitro activity of **PDZ1i**. Note that specific IC50 values can vary depending on the cell line and assay conditions.

Cancer Type	Cell Line	Assay	IC50 (µM)	Reference
Glioblastoma	U87MG	Invasion Assay	~50	
Glioblastoma	T98G	Invasion Assay	~50	
Breast Cancer	MDA-MB-231	Migration Assay	Not specified	
Prostate Cancer	DU-145	Invasion Assay	~50	

In Vivo Efficacy of PDZ1i Combination Therapy

This table summarizes the in vivo efficacy of **PDZ1i** in combination with radiation therapy in an orthotopic glioblastoma mouse model.

Treatment Group	Median Survival (days)	Outcome	Reference
DMSO (Control)	55.5	-	
PDZ1i (30 mg/kg)	65.5	Increased survival	
DMSO + Radiation (2.5 Gy x 4)	67	Increased survival	
PDZ1i + Radiation	78.8	Significantly increased survival	

Experimental Protocols

Experimental Workflow for In Vitro Combination Studies

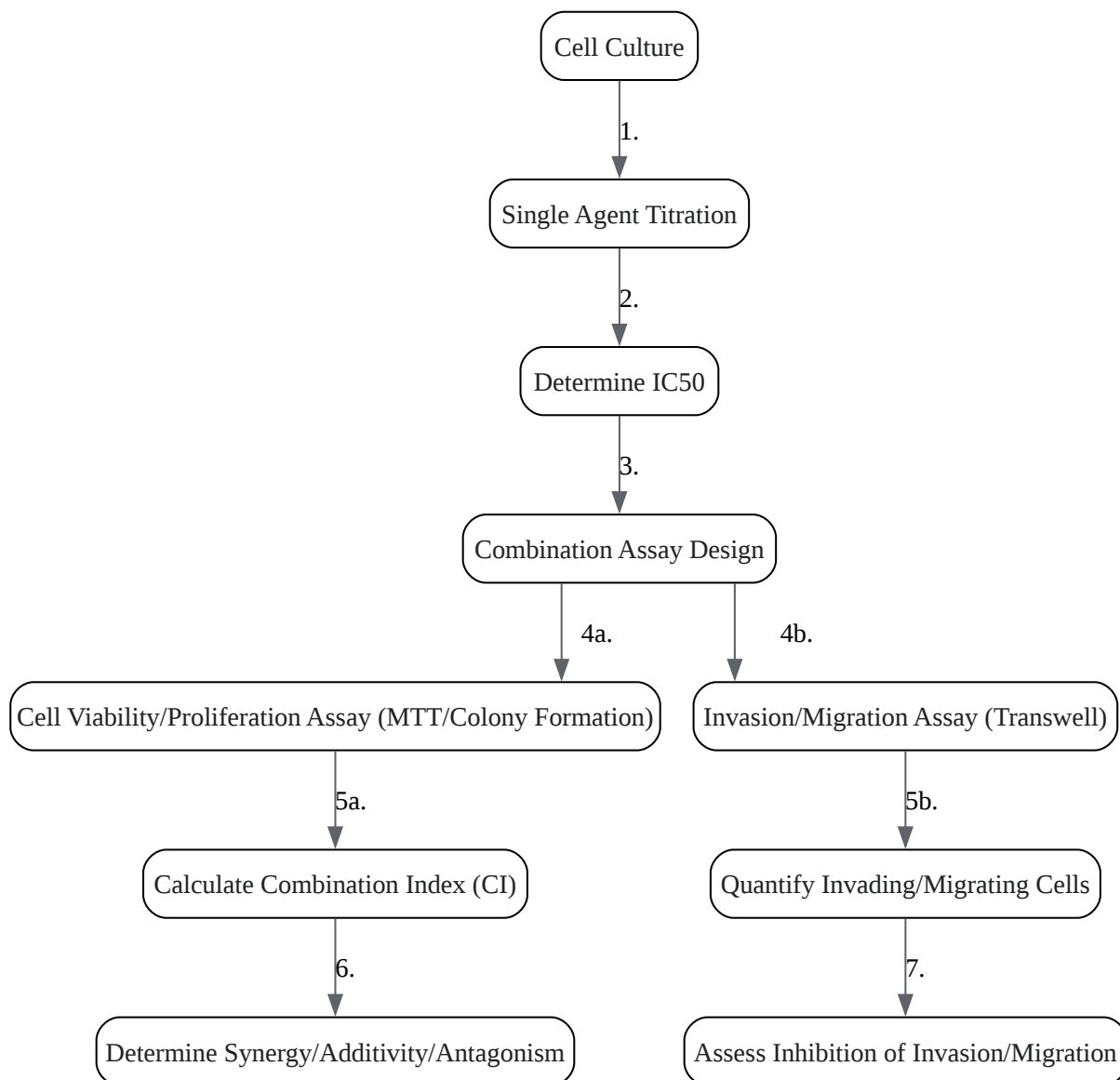

[Click to download full resolution via product page](#)

Figure 2: Workflow for in vitro evaluation of **PDZ1i** combination therapy.

Cell Viability Assay (MTT Assay) to Determine IC50

Objective: To determine the concentration of **PDZ1i** and the combination agent that inhibits cell viability by 50% (IC50).

Materials:

- Cancer cell line of interest (e.g., U87MG glioblastoma cells)
- Complete culture medium (e.g., DMEM with 10% FBS)
- **PDZ1i**
- Combination agent (e.g., temozolomide)
- DMSO (vehicle control)
- 96-well plates
- MTT (3-(4,5-dimethylthiazol-2-yl)-2,5-diphenyltetrazolium bromide) solution (5 mg/mL in PBS)
- Solubilization solution (e.g., DMSO or 0.01 M HCl in 10% SDS)
- Microplate reader

Protocol:

- Seed cells in a 96-well plate at a density of 5,000-10,000 cells/well in 100 μ L of complete medium.
- Incubate for 24 hours at 37°C and 5% CO₂ to allow for cell attachment.
- Prepare serial dilutions of **PDZ1i** and the combination agent in complete medium.
- Remove the medium from the wells and add 100 μ L of the drug dilutions. Include wells with vehicle control (DMSO) and untreated cells.
- Incubate for 48-72 hours.
- Add 10 μ L of MTT solution to each well and incubate for 2-4 hours at 37°C.

- Remove the medium and add 100 μ L of solubilization solution to each well to dissolve the formazan crystals.
- Measure the absorbance at 570 nm using a microplate reader.
- Calculate the percentage of cell viability relative to the untreated control and plot a dose-response curve to determine the IC₅₀ value.

Transwell Matrigel Invasion Assay

Objective: To assess the effect of **PDZ1i** combination therapy on the invasive capacity of cancer cells.

Materials:

- Transwell inserts (8 μ m pore size) for 24-well plates
- Matrigel Basement Membrane Matrix
- Serum-free medium
- Complete medium (chemoattractant)
- **PDZ1i** and combination agent
- Cotton swabs
- Methanol or 4% paraformaldehyde for fixation
- Crystal violet stain (0.5%)

Protocol:

- Thaw Matrigel on ice and dilute with cold serum-free medium (1:3 to 1:5).
- Coat the upper surface of the Transwell inserts with 50-100 μ L of the diluted Matrigel and incubate at 37°C for 1-2 hours to solidify.

- Harvest and resuspend cells in serum-free medium containing the desired concentrations of **PDZ1i**, the combination agent, or the combination of both.
- Seed 2.5×10^4 to 5×10^4 cells in 100 μ L of the cell suspension into the upper chamber of the inserts.
- Add 600 μ L of complete medium (containing 10% FBS as a chemoattractant) to the lower chamber.
- Incubate for 24-48 hours at 37°C and 5% CO₂.
- After incubation, remove the non-invading cells from the upper surface of the membrane with a cotton swab.
- Fix the invaded cells on the lower surface of the membrane with methanol or paraformaldehyde for 10-15 minutes.
- Stain the cells with crystal violet for 10-20 minutes.
- Wash the inserts with water and allow them to air dry.
- Count the number of invaded cells in several random fields under a microscope.

Western Blot Analysis

Objective: To investigate the effect of **PDZ1i** combination therapy on the expression and phosphorylation of key signaling proteins.

Materials:

- Cancer cells treated with **PDZ1i** and/or combination agent
- RIPA lysis buffer with protease and phosphatase inhibitors
- BCA protein assay kit
- SDS-PAGE gels
- PVDF membrane

- Blocking buffer (e.g., 5% non-fat milk or BSA in TBST)
- Primary antibodies (e.g., anti-MDA-9/Syntenin, anti-phospho-Src (Tyr416), anti-Src, anti-MMP-2, anti-MMP-9, anti-actin)
- HRP-conjugated secondary antibodies
- ECL detection reagent

Protocol:

- Lyse the treated cells with RIPA buffer and determine the protein concentration using a BCA assay.
- Denature 20-30 µg of protein from each sample by boiling in Laemmli sample buffer.
- Separate the proteins by SDS-PAGE and transfer them to a PVDF membrane.
- Block the membrane with blocking buffer for 1 hour at room temperature.
- Incubate the membrane with the primary antibody (e.g., rabbit anti-phospho-Src at 1:1000 dilution in 5% BSA/TBST) overnight at 4°C.
- Wash the membrane with TBST and incubate with the appropriate HRP-conjugated secondary antibody (e.g., anti-rabbit IgG-HRP at 1:2000 dilution) for 1 hour at room temperature.
- Wash the membrane again and detect the protein bands using an ECL detection system.
- Normalize the protein expression to a loading control like actin.

Co-Immunoprecipitation (Co-IP)

Objective: To determine if **PDZ1i** disrupts the interaction between MDA-9/Syntenin and its binding partners (e.g., c-Src).

Materials:

- Treated cell lysates

- Co-IP lysis buffer (non-denaturing)
- Primary antibody for immunoprecipitation (e.g., anti-MDA-9/Syntenin)
- Protein A/G agarose or magnetic beads
- Primary antibody for Western blotting (e.g., anti-c-Src)

Protocol:

- Lyse cells in a non-denaturing Co-IP buffer.
- Pre-clear the lysate by incubating with protein A/G beads for 1 hour at 4°C.
- Incubate the pre-cleared lysate with the immunoprecipitating antibody (e.g., anti-MDA-9/Syntenin) overnight at 4°C.
- Add protein A/G beads to the lysate and incubate for 2-4 hours at 4°C to capture the antibody-protein complexes.
- Wash the beads several times with Co-IP buffer to remove non-specific binding.
- Elute the protein complexes from the beads by boiling in SDS-PAGE sample buffer.
- Analyze the eluted proteins by Western blotting using an antibody against the putative interacting protein (e.g., anti-c-Src).

Orthotopic Glioblastoma Mouse Model

Objective: To evaluate the in vivo efficacy of **PDZ1i** combination therapy on tumor growth and survival.



[Click to download full resolution via product page](#)

Figure 3: Workflow for in vivo evaluation of **PDZ1i** combination therapy.

Materials:

- Immunocompromised mice (e.g., nude or SCID)
- Glioblastoma cells expressing luciferase (e.g., U87MG-luc)
- Stereotactic injection apparatus
- **PDZ1i** (formulated for in vivo use)
- Combination agent (e.g., radiation source)
- Bioluminescence imaging system

Protocol:

- Intracranially inject 1×10^5 to 2×10^5 U87MG-luc cells into the striatum of anesthetized mice using a stereotactic frame.
- Allow tumors to establish for 7-10 days, monitoring tumor growth by bioluminescence imaging.
- Randomize mice into treatment groups (e.g., Vehicle, **PDZ1i** alone, Radiation alone, **PDZ1i** + Radiation).
- Administer **PDZ1i** (e.g., 30 mg/kg, intraperitoneally) daily or on a specified schedule. For combination with radiation, **PDZ1i** is often administered 1-2 hours prior to irradiation.
- Deliver focal radiation to the tumor-bearing region of the brain (e.g., 2.5 Gy for 4 consecutive days).
- Monitor tumor growth regularly using bioluminescence imaging.
- Monitor animal health and body weight.
- Record survival data and generate Kaplan-Meier survival curves.

- At the end of the study, harvest brains for histological analysis to assess tumor size, invasion, and proliferation (e.g., Ki-67 staining).

Conclusion

The experimental designs and protocols provided in these application notes offer a robust framework for the preclinical evaluation of **PDZ1i** in combination with other cancer therapies. By systematically assessing the effects of these combinations on key cancer hallmarks such as proliferation, invasion, and in vivo tumor growth, researchers can generate the critical data needed to advance the development of novel and more effective treatment strategies for metastatic cancers. The provided diagrams and tables serve as a guide for visualizing complex biological processes and organizing experimental data for clear and concise presentation.

Need Custom Synthesis?

BenchChem offers custom synthesis for rare earth carbides and specific isotopic labeling.

Email: info@benchchem.com or [Request Quote Online](#).

References

- [1. Inhibition of radiation-induced glioblastoma invasion by genetic and pharmacological targeting of MDA-9/Syntenin - PMC \[pmc.ncbi.nlm.nih.gov\]](#)
- [2. MDA-9/Syntenin \(SDCBP\): Novel gene and therapeutic target for cancer metastasis - PMC \[pmc.ncbi.nlm.nih.gov\]](#)
- [3. Pharmacological inhibition of MDA-9/Syntenin blocks breast cancer metastasis through suppression of IL-1 \$\beta\$ - PMC \[pmc.ncbi.nlm.nih.gov\]](#)
- [4. aacrjournals.org \[aacrjournals.org\]](#)
- To cite this document: BenchChem. [Application Notes and Protocols for PDZ1i Combination Therapy Experimental Design]. BenchChem, [2026]. [Online PDF]. Available at: [\[https://www.benchchem.com/product/b10861142/docs#application-notes-and-protocols-for-pdz1i-combination-therapy-experimental-design\]](https://www.benchchem.com/product/b10861142/docs#application-notes-and-protocols-for-pdz1i-combination-therapy-experimental-design)

Disclaimer & Data Validity:

The information provided in this document is for Research Use Only (RUO) and is strictly not intended for diagnostic or therapeutic procedures. While BenchChem strives to provide accurate protocols, we make no warranties, express or implied, regarding the fitness of this product for every specific experimental setup.

Technical Support: The protocols provided are for reference purposes. Unsure if this reagent suits your experiment?

Need Industrial/Bulk Grade? [Request Custom Synthesis Quote](#)

BenchChem

Our mission is to be the trusted global source of essential and advanced chemicals, empowering scientists and researchers to drive progress in science and industry.

Contact

Address: 3281 E Guasti Rd
Ontario, CA 91761, United States
Phone: (601) 213-4426
Email: info@benchchem.com

[Contact our Ph.D. Support Team for a compatibility check](#)