

Application Notes and Protocols for Flow Cytometry Analysis Following SR12418 Treatment

Author: BenchChem Technical Support Team. **Date:** April 2026

Compound of Interest

Compound Name: SR12418
Cat. No.: B10861337

[Get Quote](#)

For Researchers, Scientists, and Drug Development Professionals

Introduction

SR12418 is a synthetic ligand that acts as a potent agonist of the nuclear receptors REV-ERB α and REV-ERB β .^[1] These receptors are critical components of the circadian clock and have been shown to play a significant role in regulating metabolic and inflammatory processes.^{[2][3]} ^[4] In the context of immunology, REV-ERB α is a key cell-intrinsic negative regulator of T helper 17 (TH17) cell development.^[1] **SR12418** has demonstrated efficacy in suppressing TH17-mediated inflammation in preclinical models of autoimmune diseases such as experimental autoimmune encephalomyelitis (EAE) and colitis, making it a compound of interest for therapeutic development.^{[1][2]}

These application notes provide a detailed overview of the use of flow cytometry to analyze cellular responses to **SR12418** treatment, with a focus on its effects on TH17 cell differentiation and function. The provided protocols are intended to serve as a guide for researchers investigating the immunomodulatory properties of **SR12418** and similar compounds.

Mechanism of Action of SR12418

SR12418 enhances the repressive activity of REV-ERB α and REV-ERB β .^{[3][4]} In the context of TH17 cells, REV-ERB α competes with the lineage-defining transcription factor ROR γ t for binding to regulatory elements of genes crucial for TH17 function, most notably the gene encoding for Interleukin-17A (IL-17A).^{[1][5]} By activating REV-ERB, **SR12418** leads to the repression of ROR γ t expression and activity, which in turn downregulates the expression of IL-17A and other pro-inflammatory cytokines, thereby inhibiting TH17 cell development and effector function.^[1]

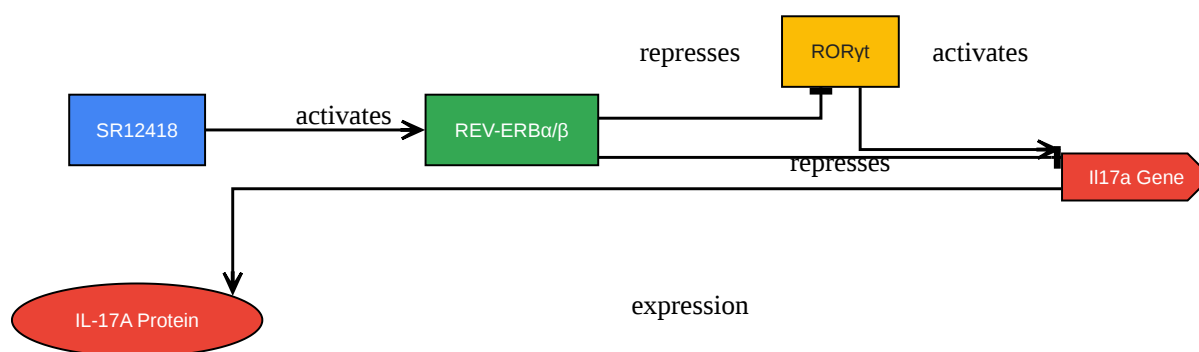

[Click to download full resolution via product page](#)

Caption: **SR12418** signaling pathway in TH17 cells.

Data Presentation

The following tables summarize quantitative data from studies analyzing the effects of **SR12418** treatment on T cell populations using flow cytometry.

Table 1: In Vitro Effects of **SR12418** on Mouse CD4⁺ T Cells under TH17-Polarizing Conditions

Treatment	% IL-17A+ Cells	RORyt MFI	Reference
Vehicle (DMSO)	Baseline	Baseline	[1]
SR12418 (5 μ M)	Significantly Decreased	Decreased	[1]
SR9009 (5 μ M)	Significantly Decreased	Decreased	[1]

MFI: Mean Fluorescence Intensity

Table 2: In Vivo Effects of **SR12418** on T Cell Populations in a Mouse Model of EAE

Cell Population	Location	Vehicle-Treated	SR12418-Treated	Reference
CD3+ CD4+ T Cells	Draining LNs & CNS	Baseline	Reduced Frequency & Number	[2]
RORyt+ Cells	LNs & CNS	Baseline	Significantly Decreased Frequency & Number	[1][2]
GM-CSF+ T Cells	LNs & CNS	Baseline	Significantly Lower Absolute Number	[1]
IL-17A+ Cells	LNs & CNS	Baseline	Decreased Frequency & Number	[1]
IL-17A+ IFN γ + Cells	LNs & CNS	Baseline	Decreased Number	[1]

LNs: Lymph Nodes; CNS: Central Nervous System

Experimental Protocols

The following are detailed protocols for the flow cytometric analysis of immune cells following **SR12418** treatment.

Protocol 1: Intracellular Staining for Cytokines (IL-17A, IFN γ) and Transcription Factors (ROR γ t) in Mouse Splenocytes or Lymph Node Cells

This protocol is designed for the analysis of TH17 cell populations from in vivo models.

Materials:

- Single-cell suspension from spleen or lymph nodes
- **SR12418** or vehicle control (for in vivo treatment)
- Cell stimulation cocktail (e.g., PMA, Ionomycin, and Brefeldin A or Monensin)
- Phosphate-Buffered Saline (PBS)
- FACS Buffer (PBS + 2% FBS + 0.05% Sodium Azide)
- Fixable Viability Dye
- Anti-mouse CD16/CD32 (Fc Block)
- Fluorochrome-conjugated antibodies against surface markers (e.g., CD4, CD45)
- Fixation/Permeabilization Buffer
- Permeabilization Wash Buffer
- Fluorochrome-conjugated antibodies against intracellular markers (e.g., IL-17A, IFN γ , ROR γ t)
- Flow cytometer

Procedure:

- Cell Preparation: Prepare a single-cell suspension from the spleen or lymph nodes of vehicle- or **SR12418**-treated mice.
- Cell Stimulation (for cytokine analysis): Resuspend cells at $1-2 \times 10^6$ cells/mL in complete RPMI medium. Add a cell stimulation cocktail and incubate for 4-6 hours at 37°C, 5% CO₂.
- Surface Staining:
 - Wash cells with PBS and resuspend in FACS buffer.
 - Stain with a fixable viability dye according to the manufacturer's instructions.
 - Wash cells and resuspend in FACS buffer containing Fc Block. Incubate for 10-15 minutes at 4°C.
 - Add the cocktail of fluorochrome-conjugated surface antibodies and incubate for 30 minutes at 4°C in the dark.
 - Wash cells twice with FACS buffer.
- Fixation and Permeabilization:
 - Resuspend cells in Fixation/Permeabilization buffer and incubate for 30-60 minutes at 4°C in the dark.
 - Wash cells twice with Permeabilization Wash Buffer.
- Intracellular Staining:
 - Resuspend the fixed and permeabilized cells in Permeabilization Wash Buffer containing the cocktail of fluorochrome-conjugated intracellular antibodies.
 - Incubate for 30-45 minutes at 4°C in the dark.
 - Wash cells twice with Permeabilization Wash Buffer.

- Data Acquisition: Resuspend cells in FACS buffer and acquire data on a flow cytometer. Ensure to collect a sufficient number of events for robust statistical analysis.

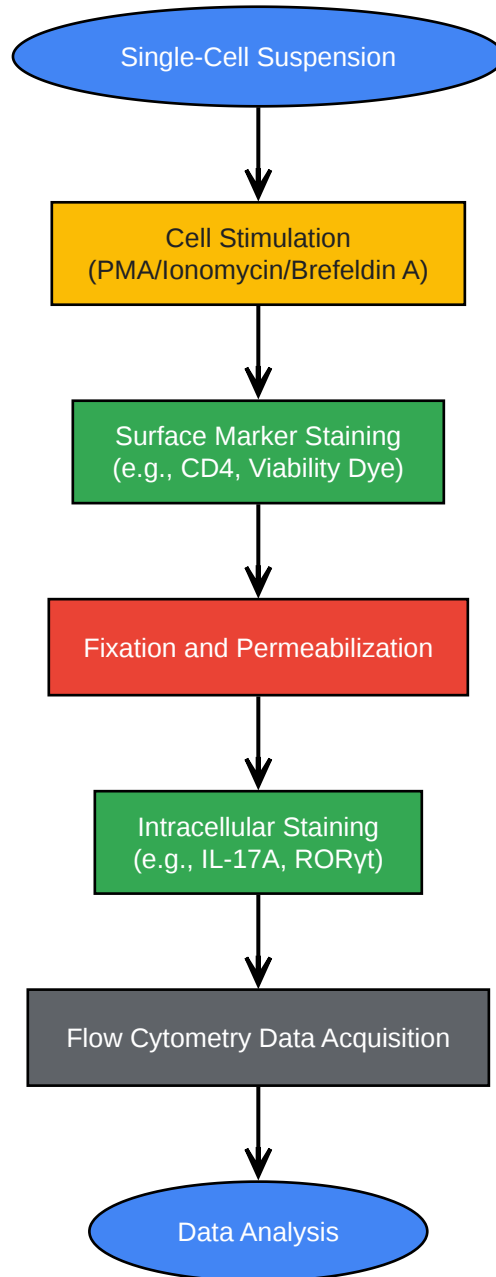

[Click to download full resolution via product page](#)

Caption: Experimental workflow for intracellular flow cytometry.

Protocol 2: Apoptosis Assay using Annexin V and Propidium Iodide (PI) Staining

This protocol can be used to assess if **SR12418** treatment induces apoptosis in target cells.

Materials:

- Cells treated with **SR12418** or vehicle control
- Annexin V Binding Buffer
- Fluorochrome-conjugated Annexin V
- Propidium Iodide (PI) or other viability dye (e.g., 7-AAD)
- Flow cytometer

Procedure:

- Cell Harvesting: Harvest cells after treatment with **SR12418** or vehicle.
- Washing: Wash cells twice with cold PBS.
- Resuspension: Resuspend cells in Annexin V Binding Buffer at a concentration of 1×10^6 cells/mL.
- Staining:
 - Add fluorochrome-conjugated Annexin V to the cell suspension.
 - Gently vortex and incubate for 15 minutes at room temperature in the dark.
 - Add PI or another viability dye to the cell suspension.
- Data Acquisition: Analyze the cells on a flow cytometer immediately after staining.

Data Interpretation:

- Annexin V- / PI- : Live cells
- Annexin V+ / PI- : Early apoptotic cells

- Annexin V+ / PI+ : Late apoptotic/necrotic cells
- Annexin V- / PI+ : Necrotic cells

Protocol 3: Cell Cycle Analysis using Propidium Iodide (PI) Staining

This protocol is to determine the effect of **SR12418** on cell cycle progression.

Materials:

- Cells treated with **SR12418** or vehicle control
- Cold 70% Ethanol
- PBS
- RNase A
- Propidium Iodide (PI) staining solution
- Flow cytometer

Procedure:

- Cell Harvesting: Harvest cells after treatment.
- Fixation: Resuspend the cell pellet in cold PBS. While vortexing gently, add cold 70% ethanol dropwise to fix the cells. Incubate at -20°C for at least 2 hours.
- Washing: Wash the fixed cells with PBS.
- RNase Treatment: Resuspend the cells in PBS containing RNase A and incubate for 30 minutes at 37°C.
- Staining: Add PI staining solution and incubate for 15 minutes at room temperature in the dark.

- **Data Acquisition:** Analyze the samples on a flow cytometer using a linear scale for the PI channel.

Data Interpretation:

- The DNA content histogram will show distinct peaks corresponding to the G0/G1, S, and G2/M phases of the cell cycle. The percentage of cells in each phase can be quantified using cell cycle analysis software.

Conclusion

Flow cytometry is an indispensable tool for elucidating the cellular mechanisms of action of immunomodulatory compounds like **SR12418**. The protocols and data presented here provide a framework for investigating the impact of **SR12418** on T cell differentiation, function, and viability. These methods can be adapted to various cell types and research questions, contributing to a deeper understanding of the therapeutic potential of targeting the REV-ERB nuclear receptors.

Need Custom Synthesis?

BenchChem offers custom synthesis for rare earth carbides and specific isotopic labeling.

Email: info@benchchem.com or [Request Quote Online](#).

References

- [1. REV-ERB \$\alpha\$ Regulates TH17 Cell Development and Autoimmunity - PMC \[pmc.ncbi.nlm.nih.gov\]](#)
- [2. researchgate.net \[researchgate.net\]](#)
- [3. Targeting Nuclear Receptors for TH17-Mediated Inflammation: REV-ERB \$\alpha\$ Regulates Circadian Rhythm and Metabolism \[wap.hapres.com\]](#)
- [4. Targeting Nuclear Receptors for TH17-Mediated Inflammation: REV-ERB \$\alpha\$ Regulates Circadian Rhythm and Metabolism - PMC \[pmc.ncbi.nlm.nih.gov\]](#)
- [5. Targeting REV-ERB \$\alpha\$ for therapeutic purposes: promises and challenges - PMC \[pmc.ncbi.nlm.nih.gov\]](#)

- To cite this document: BenchChem. [Application Notes and Protocols for Flow Cytometry Analysis Following SR12418 Treatment]. BenchChem, [2026]. [Online PDF]. Available at: [<https://www.benchchem.com/product/b10861337/docs#application-notes-and-protocols-for-flow-cytometry-analysis-following-sr12418-treatment>]

Disclaimer & Data Validity:

The information provided in this document is for Research Use Only (RUO) and is strictly not intended for diagnostic or therapeutic procedures. While BenchChem strives to provide accurate protocols, we make no warranties, express or implied, regarding the fitness of this product for every specific experimental setup.

Technical Support: The protocols provided are for reference purposes. Unsure if this reagent suits your experiment?

Need Industrial/Bulk Grade? [Request Custom Synthesis Quote](#)

BenchChem

Our mission is to be the trusted global source of essential and advanced chemicals, empowering scientists and researchers to drive progress in science and industry.

Contact

Address: 3281 E Guasti Rd
Ontario, CA 91761, United States
Phone: (601) 213-4426
Email: info@benchchem.com

[Contact our Ph.D. Support Team for a compatibility check](#)