

Application Notes: Visualizing Atg4B Inhibition with Fluorescence Microscopy

Author: BenchChem Technical Support Team. **Date:** April 2026

Compound of Interest

Compound Name: *Atg4B-IN-2*

Cat. No.: *B10861317*

[Get Quote](#)

Introduction

Autophagy is a fundamental cellular process responsible for the degradation and recycling of cytoplasmic components, playing a critical role in cellular homeostasis, stress response, and disease. A key molecular event in autophagy is the formation of the autophagosome, a double-membraned vesicle that engulfs cytoplasmic cargo. The formation and maturation of the autophagosome are critically dependent on the lipidation of Microtubule-associated protein 1 light chain 3 (LC3) and other Atg8 family proteins.

The cysteine protease Atg4B is a master regulator of this process, performing two essential and distinct functions:

- **Priming (Proteolytic Cleavage):** Atg4B cleaves the precursor form, pro-LC3, to expose a C-terminal glycine residue, generating the cytosolic form, LC3-I. This step is a prerequisite for subsequent lipidation.
- **Delipidation (Deconjugation):** Atg4B removes the phosphatidylethanolamine (PE) lipid moiety from membrane-bound LC3-II, recycling LC3 back to the cytosol for reuse. This delipidation from the outer autophagosomal membrane is crucial for efficient autophagosome maturation and fusion with lysosomes.

Atg4B-IN-2 is a chemical inhibitor designed to target the enzymatic activity of Atg4B. By inhibiting Atg4B, researchers can effectively block the LC3 conjugation cycle, providing a powerful tool to dissect the role of Atg4B in autophagy and to study the consequences of impaired autophagosome formation. This document provides detailed protocols for visualizing and quantifying the cellular effects of **Atg4B-IN-2** using established fluorescence microscopy techniques.

Atg4B Signaling Pathway and Point of Inhibition

The following diagram illustrates the central role of Atg4B in the LC3 processing pathway and the mechanism of action for an inhibitor like **Atg4B-IN-2**.

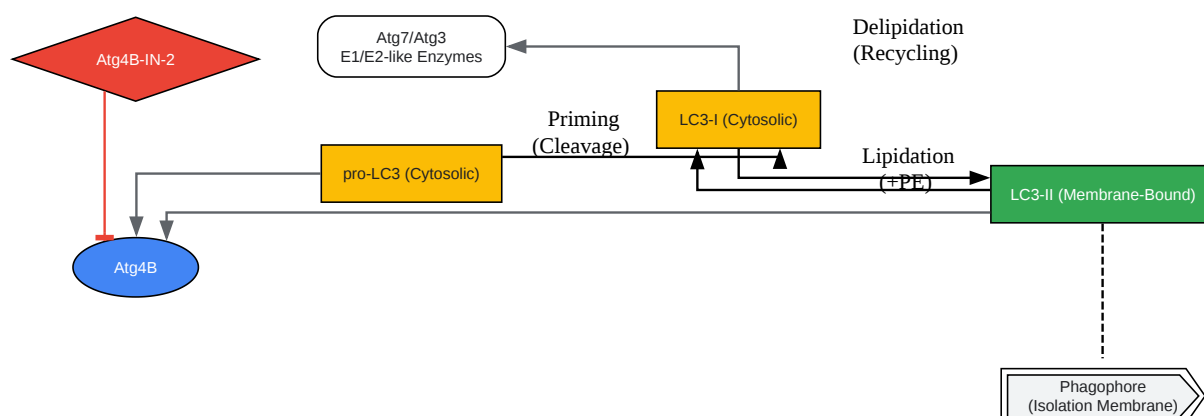

[Click to download full resolution via product page](#)

Caption: Atg4B's dual role in autophagy and inhibition by **Atg4B-IN-2**.

Fluorescence Microscopy-Based Assays

Two primary fluorescence microscopy assays are recommended for observing the effects of Atg4B inhibition: the GFP-LC3 Puncta Formation Assay and the Tandem mRFP-GFP-LC3 Autophagic Flux Assay.

GFP-LC3 Puncta Formation Assay

- Principle: Under basal conditions, GFP-LC3 is diffusely distributed in the cytoplasm.[1] Upon autophagy induction, LC3-I is lipidated to form LC3-II, which is recruited to the nascent autophagosome membrane. This relocalization is visualized as the formation of distinct fluorescent puncta.[1]
- Expected Effect of **Atg4B-IN-2**: Since Atg4B is required for the initial priming of pro-LC3 to LC3-I, its inhibition will prevent the formation of LC3-II. Consequently, treatment with **Atg4B-IN-2** is expected to block the formation of GFP-LC3 puncta, even under autophagy-inducing conditions (e.g., starvation).[2][3] This is in stark contrast to late-stage autophagy inhibitors (like chloroquine), which cause an accumulation of puncta.[4]

Autophagic Flux Assay using Tandem mRFP-GFP-LC3

- Principle: This assay utilizes a fusion protein, mRFP-GFP-LC3, to monitor the progression of autophagy (autophagic flux).[5] The tandem construct allows differentiation between autophagosomes and autolysosomes based on pH. In neutral-pH autophagosomes, both GFP and mRFP fluoresce, appearing as yellow puncta.[5] When an autophagosome fuses with an acidic lysosome to form an autolysosome, the low pH quenches the GFP signal, while the acid-stable mRFP continues to fluoresce, resulting in red-only puncta.[5][6]
- Expected Effect of **Atg4B-IN-2**: By blocking the first step in LC3 processing, **Atg4B-IN-2** prevents the tandem-tagged LC3 from being lipidated and incorporated into autophagosomes. Therefore, treatment will result in a predominantly diffuse cytoplasmic signal and a significant reduction in both yellow (autophagosome) and red (autolysosome) puncta, indicating a complete blockade of autophagic flux at the initiation stage.

Quantitative Data on Atg4B Inhibition

While specific quantitative data for **Atg4B-IN-2** is not widely available in peer-reviewed literature, the following table summarizes representative data from studies using other known Atg4B inhibitors. This data illustrates the expected quantitative effects of potent Atg4B inhibition on LC3 processing as visualized by fluorescence microscopy.

Inhibitor	Cell Line	Treatment Condition	Assay	Key Finding	Reference
Tioconazole	GFP-LC3 Stably Expressing Cells	Starvation + Chloroquine	GFP-LC3 Puncta Assay	Significant, dose- dependent reduction in the number of GFP-LC3 puncta per cell.	[3]
NSC185058	Saos-2 Cells	Not Specified	LC3 Puncta Assay	Reduction in the formation of LC3 puncta.	[7]

Note: The data presented are for representative Atg4B inhibitors and serve to illustrate the expected experimental outcomes when using **Atg4B-IN-2**. Researchers should perform dose-response experiments to determine the optimal concentration of **Atg4B-IN-2** for their specific cell system.

Protocols

Protocol 1: GFP-LC3 Puncta Formation Assay

This protocol details the steps to quantify changes in autophagosome formation in response to **Atg4B-IN-2** treatment in cells expressing GFP-LC3.

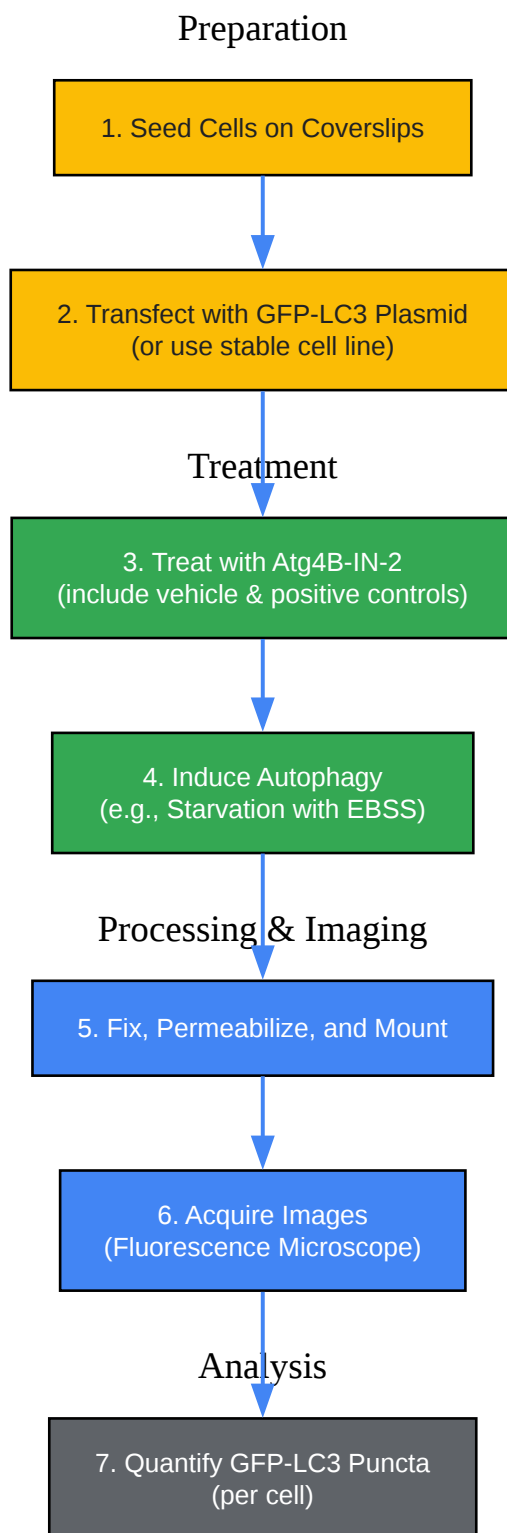

[Click to download full resolution via product page](#)

Caption: Workflow for the GFP-LC3 Puncta Formation Assay.

A. Materials

- Cells of interest (e.g., HeLa, MEFs, U2OS)
- GFP-LC3 expression plasmid or a cell line stably expressing GFP-LC3
- Complete growth medium (e.g., DMEM + 10% FBS)
- Starvation medium (e.g., Earle's Balanced Salt Solution - EBSS)
- **Atg4B-IN-2** (dissolved in appropriate solvent, e.g., DMSO)
- Vehicle control (e.g., DMSO)
- Glass coverslips (sterile, 12-18 mm)
- 24-well or 12-well plates
- Transfection reagent
- Phosphate-Buffered Saline (PBS)
- 4% Paraformaldehyde (PFA) in PBS for fixation
- 0.1% Triton X-100 in PBS for permeabilization (optional)
- DAPI nuclear stain
- Antifade mounting medium

B. Experimental Procedure

- **Cell Seeding:** Seed cells onto sterile glass coverslips in a multi-well plate at a density that will result in 60-70% confluency at the time of the experiment. Allow cells to adhere overnight.
- **Transfection (if not using a stable cell line):** Transfect cells with the GFP-LC3 plasmid according to the manufacturer's protocol for your chosen transfection reagent. Allow 24-48 hours for protein expression.

- Inhibitor Treatment:
 - Prepare working solutions of **Atg4B-IN-2** in complete growth medium. A dose-response curve is recommended (e.g., 0.1, 1, 10 μ M).
 - Include a vehicle-only control.
 - Aspirate the medium from the cells and add the medium containing the inhibitor or vehicle.
 - Pre-incubate cells with **Atg4B-IN-2** for a designated time (e.g., 1-2 hours) prior to autophagy induction.
- Autophagy Induction:
 - To induce autophagy, aspirate the treatment medium and wash the cells once with warm PBS.
 - Add pre-warmed starvation medium (EBSS), also containing the appropriate concentration of **Atg4B-IN-2** or vehicle.
 - Incubate for 1-4 hours, depending on the cell type.[8]
- Fixation and Staining:
 - Aspirate the starvation medium and wash cells twice with cold PBS.
 - Fix the cells with 4% PFA for 15-20 minutes at room temperature.[8]
 - Wash three times with PBS.
 - (Optional) Permeabilize with 0.1% Triton X-100 for 10 minutes. Wash three times with PBS.
 - Incubate with DAPI solution for 5 minutes to stain nuclei.
 - Wash twice with PBS.
- Mounting and Imaging:

- Carefully mount the coverslips onto glass slides using a drop of antifade mounting medium.
- Image the cells using a fluorescence or confocal microscope with appropriate filter sets for GFP and DAPI. Acquire images from multiple random fields for each condition.[9]
- Image Analysis and Quantification:
 - Using image analysis software (e.g., ImageJ/Fiji, CellProfiler), count the number of distinct GFP-LC3 puncta per cell.
 - Use the DAPI stain to identify individual cells and define cellular boundaries.
 - A cell is often considered "puncta-positive" if it contains >5-10 distinct puncta.
 - Calculate the average number of puncta per cell and/or the percentage of puncta-positive cells for each condition.
 - Compare the results from **Atg4B-IN-2** treated cells to the vehicle control under both basal and starvation conditions.

Protocol 2: Autophagic Flux Assay using Tandem mRFP-GFP-LC3

This protocol allows for a more dynamic assessment of autophagy by distinguishing between autophagosomes and autolysosomes.

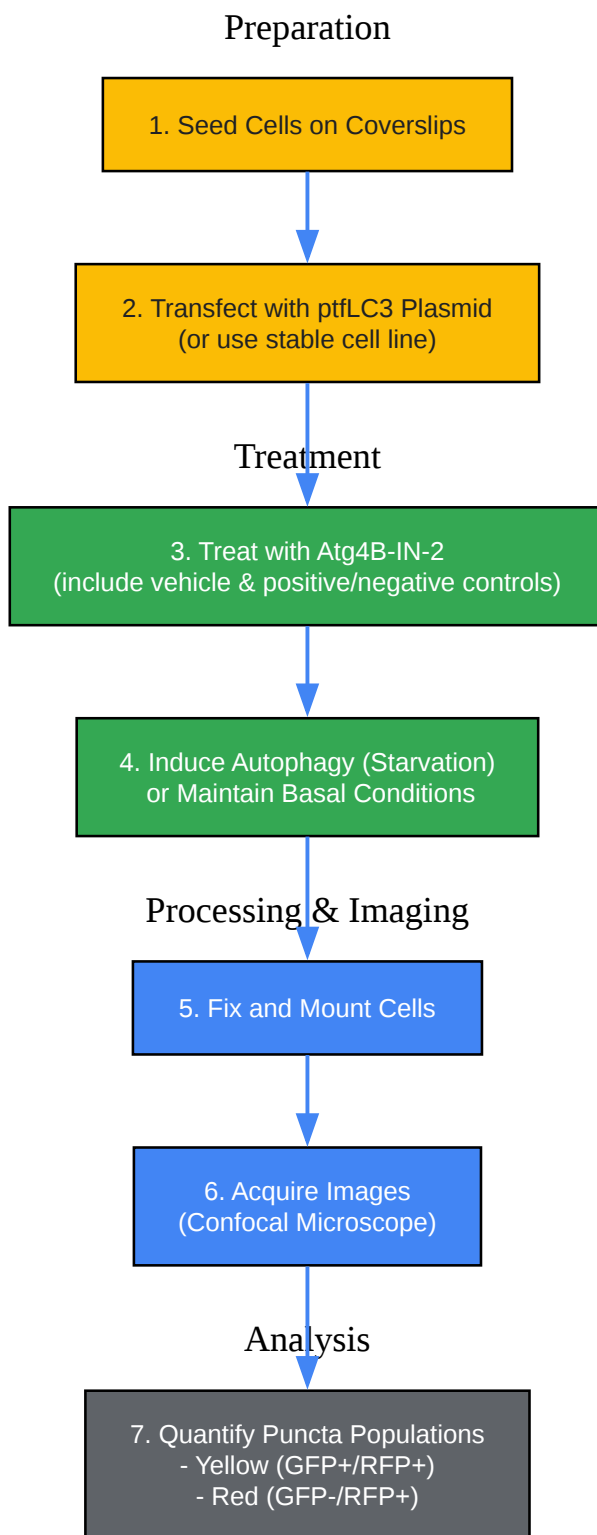

[Click to download full resolution via product page](#)

Caption: Workflow for the Tandem mRFP-GFP-LC3 Autophagic Flux Assay.

A. Materials

- All materials from Protocol 1.
- Tandem mRFP-GFP-LC3 plasmid (e.g., ptfLC3) or a cell line stably expressing it.[6][8]
- Confocal microscope is highly recommended for clear separation of signals.

B. Experimental Procedure

- Cell Seeding and Transfection: Follow steps 1 and 2 from Protocol 1, using the tandem mRFP-GFP-LC3 construct. Stable cell lines are preferred to ensure consistent expression levels.
- Inhibitor Treatment: Follow step 3 from Protocol 1. It is useful to include a late-stage inhibitor like Bafilomycin A1 or Chloroquine as a positive control for autophagic flux blockage, which will cause an accumulation of yellow (autophagosome) puncta.
- Autophagy Induction: Follow step 4 from Protocol 1.
- Fixation and Mounting: Follow steps 5 and 6a from Protocol 1 (permeabilization is generally not required).
- Image Acquisition:
 - Use a confocal laser scanning microscope for optimal results.[6]
 - Acquire images sequentially for the GFP channel (e.g., 488 nm excitation) and the mRFP channel (e.g., 561 nm excitation) to prevent spectral bleed-through.
 - Capture Z-stacks to ensure all puncta within a cell are imaged.
- Image Analysis and Quantification:
 - Merge the green and red channels.
 - Using image analysis software, identify and count two populations of puncta within each cell:[6]

- Autophagosomes: Yellow puncta (colocalization of GFP and mRFP signals).
- Autolysosomes: Red-only puncta (mRFP signal without a corresponding GFP signal).
- Calculate the average number of yellow and red puncta per cell for each experimental condition.
- Analyze the ratio of red to yellow puncta as an indicator of autophagic flux. A decrease in both puncta populations in **Atg4B-IN-2** treated cells indicates a block at the initiation stage.

Need Custom Synthesis?

BenchChem offers custom synthesis for rare earth carbides and specific isotopic labeling.

Email: info@benchchem.com or [Request Quote Online](#).

References

- [1. Monitoring Autophagy with GFP-LC3 Reporter - PubMed \[pubmed.ncbi.nlm.nih.gov\]](#)
- [2. An Atg4B Mutant Hampers the Lipidation of LC3 Paralogues and Causes Defects in Autophagosome Closure - PMC \[pmc.ncbi.nlm.nih.gov\]](#)
- [3. researchgate.net \[researchgate.net\]](#)
- [4. The protease activity of human ATG4B is regulated by reversible oxidative modification - PMC \[pmc.ncbi.nlm.nih.gov\]](#)
- [5. Methods for the Detection of Autophagy in Mammalian Cells - PMC \[pmc.ncbi.nlm.nih.gov\]](#)
- [6. pubcompare.ai \[pubcompare.ai\]](#)
- [7. Discovery of a small molecule targeting autophagy via ATG4B inhibition and cell death of colorectal cancer cells in vitro and in vivo - PMC \[pmc.ncbi.nlm.nih.gov\]](#)
- [8. proteolysis.jp \[proteolysis.jp\]](#)
- [9. proteolysis.jp \[proteolysis.jp\]](#)
- To cite this document: BenchChem. [Application Notes: Visualizing Atg4B Inhibition with Fluorescence Microscopy]. BenchChem, [2026]. [Online PDF]. Available at: [\[https://www.benchchem.com/product/b10861317/docs#application-notes-visualizing-atg4b-inhibition-with-fluorescence-microscopy\]](https://www.benchchem.com/product/b10861317/docs#application-notes-visualizing-atg4b-inhibition-with-fluorescence-microscopy)

Disclaimer & Data Validity:

The information provided in this document is for Research Use Only (RUO) and is strictly not intended for diagnostic or therapeutic procedures. While BenchChem strives to provide accurate protocols, we make no warranties, express or implied, regarding the fitness of this product for every specific experimental setup.

Technical Support: The protocols provided are for reference purposes. Unsure if this reagent suits your experiment?

Need Industrial/Bulk Grade? [Request Custom Synthesis Quote](#)

BenchChem

Our mission is to be the trusted global source of essential and advanced chemicals, empowering scientists and researchers to drive progress in science and industry.

Contact

Address: 3281 E Guasti Rd

Ontario, CA 91761, United States

Phone: (601) 213-4426

Email: info@benchchem.com

[Contact our Ph.D. Support Team for a compatibility check](#)