

Application Note: High-Throughput Chromogenic Screening for Small Molecule Plasmin Inhibitors

Author: BenchChem Technical Support Team. **Date:** May 2026

Compound of Interest

Compound Name: *Suc-ala-phe-lys-amc*

Cat. No.: B10861747

[Get Quote](#)

Introduction & Scientific Rationale

Plasmin (EC 3.4.21.[1]7) is the primary serine protease responsible for fibrinolysis—the physiological breakdown of blood clots. While plasmin activity is essential for vascular patency, hyperfibrinolysis can lead to life-threatening hemorrhage, particularly in trauma and surgical settings. Current clinical inhibitors like Tranexamic Acid (TXA) and Aprotinin have limitations ranging from low potency to anaphylactic risks. Consequently, the discovery of novel, high-affinity small molecule inhibitors remains a priority in hemostasis research.

This application note details a robust, automatable High-Throughput Screening (HTS) protocol for identifying plasmin inhibitors. Unlike fluorogenic assays, which can be sensitive to library autofluorescence, this protocol utilizes the chromogenic substrate S-2251 (H-D-Val-Leu-Lys-pNA). This substrate mimics the lysine-rich cleavage site of fibrin, providing a direct and physiologically relevant readout of active site inhibition.

Assay Principle

The assay relies on the amidolytic activity of plasmin. The enzyme cleaves the bond between the tripeptide (Val-Leu-Lys) and the para-nitroaniline (pNA) chromophore. Free pNA absorbs light strongly at 405 nm. In the presence of an inhibitor, the rate of pNA release is reduced.

Biological Context & Pathway

The following diagram illustrates the fibrinolytic cascade and the specific intervention point for this screen.^{[2][3]}

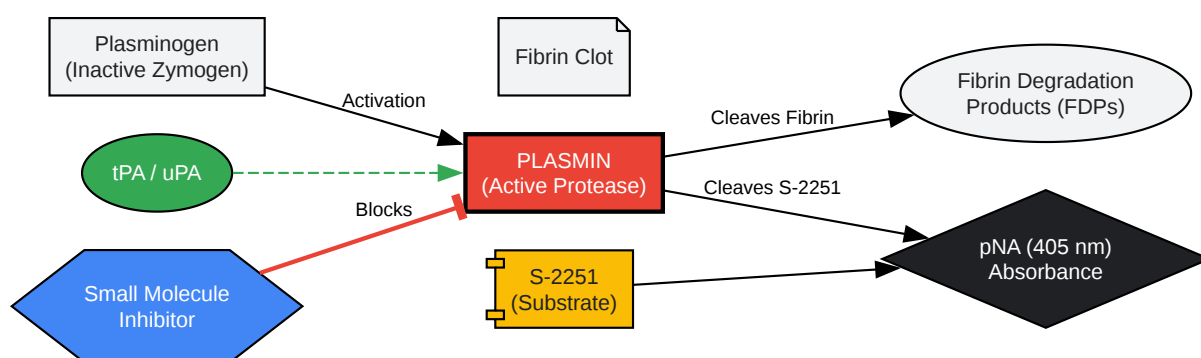

[Click to download full resolution via product page](#)

Figure 1: The fibrinolytic pathway showing Plasmin as the central node for cleavage of both physiological fibrin and the synthetic S-2251 substrate.^{[2][4][5][6]}

Materials & Reagents

To ensure reproducibility, use the following validated reagents.

Component	Specification	Recommended Source
Enzyme	Human Plasmin (purified)	Haematologic Technologies / Sigma
Substrate	S-2251 (H-D-Val-Leu-Lys-pNA)	Chromogenix (Diapharma)
Positive Control 1	Aprotinin (Serine protease inhibitor)	Sigma-Aldrich
Positive Control 2	Tranexamic Acid (Lysine analog)	Sigma-Aldrich
Assay Buffer	50 mM Tris-HCl, 100 mM NaCl, 0.01% Tween-20, pH 7.4	In-house preparation
Plate	384-well clear, flat-bottom, non-binding surface (NBS)	Corning / Greiner

Critical Formulation Note: The addition of 0.01% Tween-20 is non-negotiable. Plasmin is "sticky" and will adsorb to plastic walls without surfactant, causing artificial loss of activity and high well-to-well variance (CV%).

Experimental Protocol

This workflow is designed for a 384-well format with a final reaction volume of 50 μ L.

Step 1: Reagent Preparation[7]

- Assay Buffer: Prepare fresh 50 mM Tris-HCl (pH 7.4), 100 mM NaCl, 0.01% Tween-20. Filter through 0.22 μ m.
- Enzyme Solution: Dilute Plasmin stock to 10 nM (2x final concentration) in Assay Buffer. Keep on ice.
- Substrate Solution: Reconstitute S-2251 in deionized water to 10 mM. Dilute to 400 μ M (2x final concentration) in Assay Buffer.
 - Note: The

of S-2251 for Plasmin is approximately 200-300 μM . Screening at

ensures the assay is sensitive to competitive, non-competitive, and uncompetitive inhibitors.

Step 2: HTS Workflow (Automated)

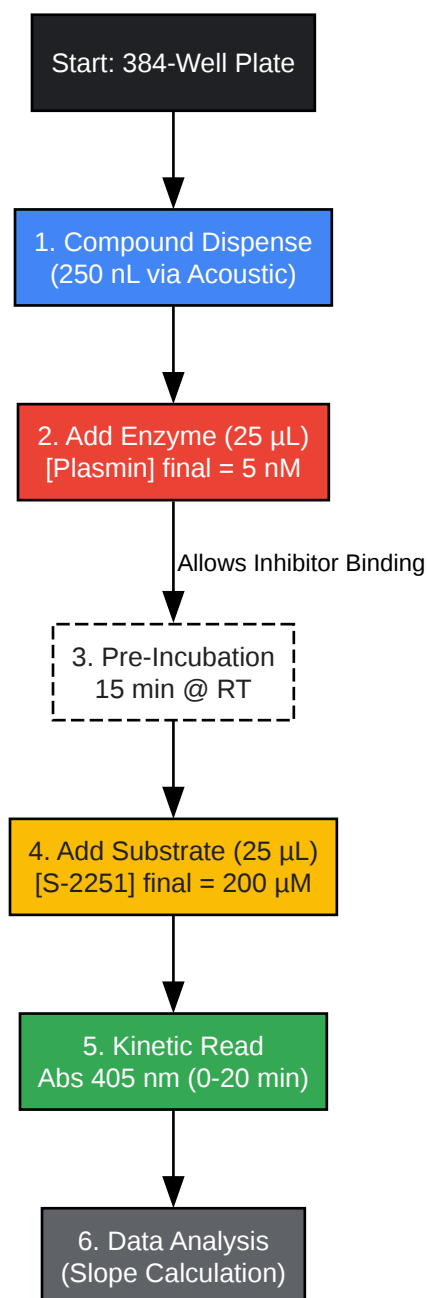

[Click to download full resolution via product page](#)

Figure 2: Step-by-step liquid handling workflow. The pre-incubation step is critical for detecting slow-binding inhibitors.

Detailed Steps:

- Compound Transfer: Dispense 250 nL of library compounds (in DMSO) into wells.
 - Controls: Column 1 (DMSO only, High Control), Column 2 (Aprotinin 10 μ M, Low Control).
- Enzyme Addition: Dispense 25 μ L of 10 nM Plasmin solution.
- Pre-Incubation: Centrifuge plate (1000 rpm, 1 min) and incubate for 15 minutes at room temperature.
 - Why? This allows the inhibitor to access the active site before the substrate competes for it.
- Substrate Addition: Dispense 25 μ L of 400 μ M S-2251 solution. Final volume = 50 μ L.
- Detection: Immediately transfer to a plate reader (e.g., BMG PHERAstar or Tecan).
 - Mode: Kinetic[7]
 - Wavelength: 405 nm[8]
 - Interval: 60 seconds
 - Duration: 20 minutes

Data Analysis & Validation

Primary Screen Analysis

Do not use a single endpoint if possible. Kinetic data is superior for identifying false positives (e.g., compounds that precipitate or are colored).

- Calculate Slope: Determine the

(mOD/min) from the linear portion of the curve (typically 2–10 minutes).

- Percent Inhibition:
 - = DMSO control (Full Activity)
 - = Aprotinin control (Full Inhibition)

Assay Robustness (Z-Factor)

A valid HTS assay must have a Z-factor > 0.5.[9][10]

- : Standard deviation of positive (DMSO) and negative (Inhibitor) controls.
- : Mean of positive and negative controls.[11]

Typical Performance:

- Signal-to-Background (S/B): > 10
- Z-Factor: > 0.7
- CV%: < 5%

Data Summary Table

Parameter	Value / Criteria	Notes
Assay Window	0.5 - 1.0 OD	Over 20 min kinetic run
Z' Factor	> 0.6	Excellent robustness
DMSO Tolerance	Up to 5%	Plasmin is stable; maintain <2% for safety
Aprotinin IC50	~280 nM	Potent active site inhibitor (Reference 1)
TXA IC50	~24 μ M	Weak inhibitor in purified systems (Reference 2)

Troubleshooting & Optimization

- Low Signal: Check the pH.[12][13] Plasmin activity drops sharply below pH 7.0. Ensure S-2251 has not hydrolyzed (solution should be clear, not yellow, before addition).
- High Background: If the "Low Control" (Aprotinin) shows activity, increase the concentration to 50 μ M or verify reagent quality.
- Compound Interference: Yellow-colored compounds can interfere with 405 nm absorbance. In this case, switch to a fluorogenic substrate like MeOSuc-Ala-Phe-Lys-AMC (Excitation 360 nm / Emission 460 nm).

References

- Sigma-Aldrich. Enzymatic Assay of Plasmin with D-Val-Leu-Lys-p-Nitroanilide.
- Mannucci, P. M. (1998). Hemostatic drugs. New England Journal of Medicine.
- Zhang, J. H., et al. (1999).[11] A Simple Statistical Parameter for Use in Evaluation and Validation of High Throughput Screening Assays. Journal of Biomolecular Screening.
- Chromogenix. S-2251™ Chromogenic Substrate for Plasmin.

Need Custom Synthesis?

BenchChem offers custom synthesis for rare earth carbides and specific isotopic labeling.

Email: info@benchchem.com or [Request Quote Online](#).

Sources

- 1. [sigmaaldrich.com](https://www.sigmaaldrich.com) [sigmaaldrich.com]
- 2. [researchgate.net](https://www.researchgate.net) [researchgate.net]
- 3. [m.youtube.com](https://www.youtube.com) [m.youtube.com]
- 4. [researchgate.net](https://www.researchgate.net) [researchgate.net]
- 5. [ashpublications.org](https://www.ashpublications.org) [ashpublications.org]
- 6. Fibrinolytic Pathways | HE [hematology.mlsascp.com]

- [7. Studies on the mechanisms of action of aprotinin and tranexamic acid as plasmin inhibitors and antifibrinolytic agents - PubMed \[pubmed.ncbi.nlm.nih.gov\]](#)
- [8. endotell.ch \[endotell.ch\]](#)
- [9. bmglabtech.com \[bmglabtech.com\]](#)
- [10. Calculating a Z-factor to assess the quality of a screening assay. - FAQ 1153 - GraphPad \[graphpad.com\]](#)
- [11. Z-factor - Wikipedia \[en.wikipedia.org\]](#)
- [12. PBST Buffer \(PBS with Tween 20\) - Sharebiology \[sharebiology.com\]](#)
- [13. endotell.ch \[endotell.ch\]](#)
- [To cite this document: BenchChem. \[Application Note: High-Throughput Chromogenic Screening for Small Molecule Plasmin Inhibitors\]. BenchChem, \[2026\]. \[Online PDF\]. Available at: \[https://www.benchchem.com/product/b10861747/docs#application-note-high-throughput-chromogenic-screening-for-small-molecule-plasmin-inhibitors\]](#)

Disclaimer & Data Validity:

The information provided in this document is for Research Use Only (RUO) and is strictly not intended for diagnostic or therapeutic procedures. While BenchChem strives to provide accurate protocols, we make no warranties, express or implied, regarding the fitness of this product for every specific experimental setup.

Technical Support: The protocols provided are for reference purposes. Unsure if this reagent suits your experiment?

Need Industrial/Bulk Grade? [Request Custom Synthesis Quote](#)

BenchChem

Our mission is to be the trusted global source of essential and advanced chemicals, empowering scientists and researchers to drive progress in science and industry.

Contact

Address: 3281 E Guasti Rd
Ontario, CA 91761, United States
Phone: (601) 213-4426
Email: info@benchchem.com

Contact our Ph.D. Support Team for a compatibility check