

Application Note: Cell-Based Assays for Characterizing Irucalantide Activity

Author: BenchChem Technical Support Team. **Date:** December 2025

Compound of Interest

Compound Name: *Irucalantide*

Cat. No.: *B10861805*

[Get Quote](#)

Audience: Researchers, scientists, and drug development professionals.

Introduction

Irucalantide is a potent and selective plasma kallikrein inhibitor.[1] Plasma kallikrein is a serine protease that plays a crucial role in the kallikrein-kinin system (KKS) by cleaving high-molecular-weight kininogen (HMWK) to produce bradykinin.[2] Bradykinin is a potent pro-inflammatory mediator that exerts its effects primarily through the bradykinin B2 receptor (B2R), a G-protein coupled receptor (GPCR).[3][4] Activation of the B2R, which is constitutively expressed in various tissues, triggers multiple signaling cascades involved in inflammation, vasodilation, increased vascular permeability, and pain.[5][6]

Given that **Irucalantide**'s mechanism of action is to inhibit the production of bradykinin, cell-based assays that measure the downstream signaling events of B2R activation are essential for characterizing its inhibitory activity. This application note details protocols for two key functional cell-based assays: a Calcium Mobilization Assay and an NF-κB Activation Assay. These assays provide a quantitative measure of how **Irucalantide** modulates the bradykinin signaling pathway in a cellular context.

Bradykinin B2 Receptor Signaling Pathway

The bradykinin B2 receptor is primarily coupled to the Gαq and Gαi families of G-proteins.[3][7] Upon bradykinin binding, the Gαq protein activates phospholipase C (PLC), which hydrolyzes phosphatidylinositol 4,5-bisphosphate (PIP2) into inositol 1,4,5-trisphosphate (IP3) and

diacylglycerol (DAG). IP3 binds to its receptors on the endoplasmic reticulum, leading to a rapid release of stored calcium (Ca^{2+}) into the cytoplasm.[3][8] This increase in intracellular calcium is a robust and readily measurable signal for receptor activation. Furthermore, GPCR signaling pathways, including those activated by bradykinin, can converge on the activation of the transcription factor Nuclear Factor-kappa B (NF- κ B), a critical regulator of inflammatory gene expression.[9][10] **Irucalantide** inhibits plasma kallikrein, thereby reducing bradykinin formation and subsequent B2R-mediated signaling.

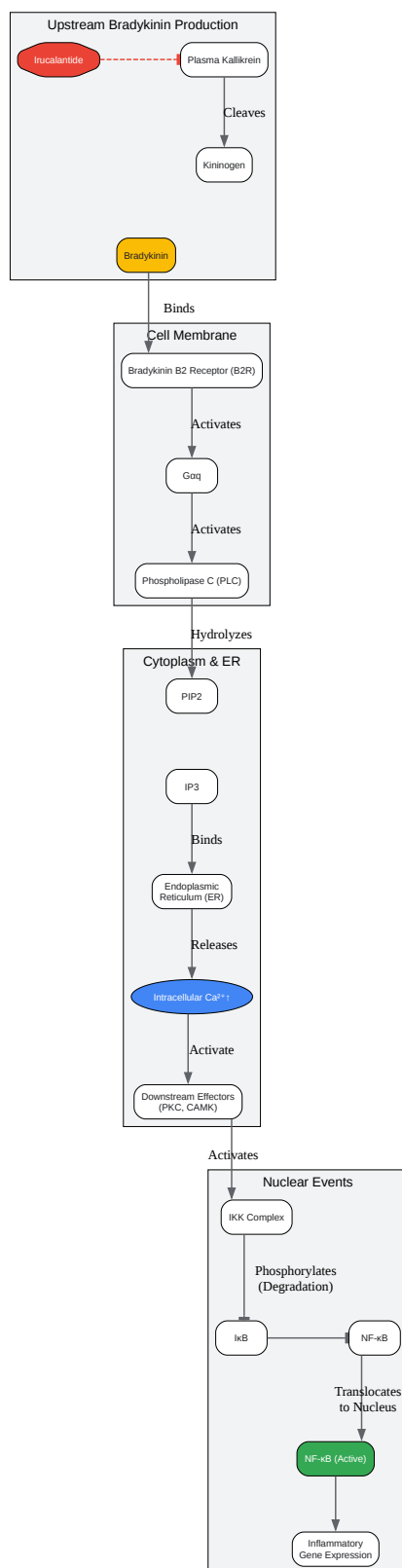

[Click to download full resolution via product page](#)

Caption: Bradykinin B2 Receptor signaling pathway and the inhibitory action of **Irucalanide**.

Quantitative Data Summary

The inhibitory activity of **Irucalantide** can be quantified by determining its half-maximal inhibitory concentration (IC50). The data below serves as an example of how results from cell-based assays can be presented. Icatibant, a direct B2R antagonist, is included for comparison.

Compound	Target	Assay Type	Cell Line	Agonist	IC50 (nM)
Irucalantide	Plasma Kallikrein	Calcium Mobilization	HEK293 (hB2R)	Kallikrein + Kininogen	1.5
Irucalantide	Plasma Kallikrein	NF-κB Translocation	HUVEC	Kallikrein + Kininogen	2.8
Icatibant	Bradykinin B2R	Calcium Mobilization	HEK293 (hB2R)	Bradykinin	0.9
Icatibant	Bradykinin B2R	NF-κB Translocation	HUVEC	Bradykinin	1.2

Note: The IC50 values presented are hypothetical examples for illustrative purposes.

Experimental Protocols

Primary Assay: Intracellular Calcium Mobilization

This assay measures the ability of **Irucalantide** to inhibit kallikrein-induced, B2R-mediated increases in intracellular calcium. It is a robust, high-throughput method for quantifying the potency of pathway inhibitors.[\[11\]](#)[\[12\]](#)

Experimental Workflow

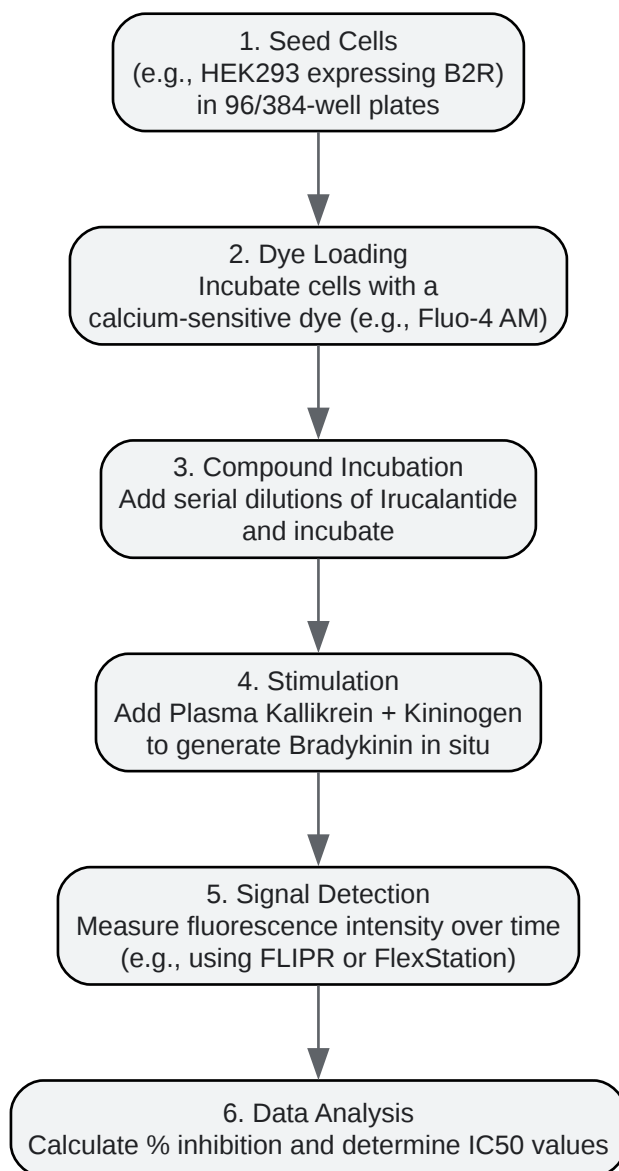

[Click to download full resolution via product page](#)

Caption: Workflow for the **Irucalantide** Calcium Mobilization Assay.

Materials and Reagents

- Cell Line: Human Embryonic Kidney (HEK293) cells stably expressing the human Bradykinin B2 Receptor (hB2R).
- Culture Medium: DMEM, 10% Fetal Bovine Serum (FBS), 1% Penicillin-Streptomycin, selection antibiotic (e.g., G418).

- Assay Buffer: Hanks' Balanced Salt Solution (HBSS) with 20 mM HEPES, pH 7.4.
- Calcium Dye: FLIPR Calcium Assay Kit or Fluo-4 AM with Pluronic F-127 and probenecid. [\[13\]](#)
- Test Compound: **Irucalantide**, dissolved in an appropriate solvent (e.g., DMSO).
- Enzyme/Substrate: Human Plasma Kallikrein and High-Molecular-Weight Kininogen (HMWK).
- Control: Known B2R antagonist (e.g., Icatibant) and vehicle control (e.g., DMSO).
- Equipment: Fluorescence plate reader with liquid handling capabilities (e.g., FLIPR Tetra®, FlexStation® 3).[\[13\]](#)[\[14\]](#)
- Plates: Black-walled, clear-bottom 96- or 384-well microplates.

Protocol

- Cell Plating:
 - The day before the assay, seed the hB2R-HEK293 cells into black-walled, clear-bottom microplates at a density that will yield a 90-100% confluent monolayer on the day of the experiment.[\[11\]](#)
 - Incubate overnight at 37°C, 5% CO₂.
- Dye Loading:
 - Prepare the calcium-sensitive dye loading solution in Assay Buffer according to the manufacturer's instructions. If using Fluo-4 AM, include probenecid to prevent dye leakage.
 - Aspirate the culture medium from the cell plate and add an equal volume of the dye loading solution to each well.[\[13\]](#)
 - Incubate the plate for 45-60 minutes at 37°C, 5% CO₂, followed by 15-30 minutes at room temperature, protected from light.

- Compound Preparation and Addition:
 - Prepare serial dilutions of **Irucalantide**, Icatibant (control), and vehicle in Assay Buffer at a concentration 5-10 times the final desired concentration.
 - Transfer the cell plate to the fluorescence plate reader.
 - The instrument will add the compound dilutions to the appropriate wells.
- Signal Measurement and Agonist Addition:
 - Allow the compounds to incubate with the cells for a predetermined time (e.g., 15-30 minutes) at room temperature.
 - Establish a stable baseline fluorescence reading for 10-20 seconds.
 - Prepare the agonist solution by mixing Plasma Kallikrein and HMWK in Assay Buffer immediately before use.
 - The plate reader's fluidics module will add the agonist solution to all wells, stimulating bradykinin production and B2R activation.
 - Immediately after agonist addition, record the fluorescence intensity every 1-2 seconds for 2-3 minutes to capture the peak calcium response.
- Data Analysis:
 - The response is typically measured as the peak fluorescence intensity minus the baseline fluorescence.
 - Normalize the data: Set the average response of the vehicle-treated wells (agonist only) as 100% activity and the response of wells with a maximal concentration of a B2R antagonist as 0% activity.
 - Plot the normalized response against the logarithm of the **Irucalantide** concentration and fit the data to a four-parameter logistic equation to determine the IC50 value.

Secondary Assay: NF- κ B Nuclear Translocation

This high-content imaging assay provides a more downstream, functional readout of B2R signaling by quantifying the translocation of the NF- κ B p65 subunit from the cytoplasm to the nucleus upon pathway activation.[15]

Materials and Reagents

- Cell Line: Human Umbilical Vein Endothelial Cells (HUVEC) or other cells endogenously expressing B2R.
- Culture Medium: EGM-2 Endothelial Cell Growth Medium.
- Test Compound/Enzyme: **Irucalantide**, Plasma Kallikrein, HMWK.
- Fixation/Permeabilization: 4% Paraformaldehyde (PFA), 0.1% Triton X-100 in PBS.
- Antibodies: Primary antibody against NF- κ B p65 (e.g., rabbit anti-p65), fluorescently-labeled secondary antibody (e.g., Alexa Fluor 488 goat anti-rabbit).
- Nuclear Stain: DAPI or Hoechst 33342.
- Equipment: High-content imaging system (e.g., ImageXpress, IN Cell Analyzer).
- Plates: Black-walled, clear-bottom 96- or 384-well imaging plates.

Protocol

- Cell Plating and Treatment:
 - Seed HUVECs into imaging plates and grow to ~80% confluency.
 - Starve cells in a low-serum medium for 2-4 hours before treatment.
 - Pre-incubate cells with serial dilutions of **Irucalantide** or vehicle control for 30 minutes.
 - Stimulate the cells by adding a pre-determined concentration of Plasma Kallikrein + HMWK. Incubate for the optimal time for NF- κ B translocation (typically 30-60 minutes), determined empirically.[15]
- Immunofluorescence Staining:

- Gently wash the cells with PBS.
- Fix the cells with 4% PFA for 15 minutes at room temperature.
- Wash three times with PBS.
- Permeabilize the cells with 0.1% Triton X-100 in PBS for 10 minutes.
- Wash three times with PBS.
- Block with a suitable blocking buffer (e.g., 3% BSA in PBS) for 1 hour.
- Incubate with the primary anti-p65 antibody diluted in blocking buffer overnight at 4°C.
- Wash three times with PBS.
- Incubate with the fluorescently-labeled secondary antibody and a nuclear counterstain (DAPI/Hoechst) for 1 hour at room temperature, protected from light.
- Wash three times with PBS, leaving the final wash on the cells for imaging.
- Image Acquisition and Analysis:
 - Acquire images using a high-content imaging system, capturing both the nuclear (DAPI/Hoechst) and p65 (e.g., Alexa 488) channels.
 - Use the system's analysis software to define the nuclear and cytoplasmic compartments for each cell based on the DAPI/Hoechst stain.
 - Quantify the fluorescence intensity of the p65 signal in both the nucleus and the cytoplasm.
 - The primary readout is the ratio of nuclear to cytoplasmic p65 intensity.[\[15\]](#)
- Data Analysis:
 - Calculate the average nuclear-to-cytoplasmic intensity ratio for each treatment condition.

- Normalize the data to positive (agonist only) and negative (unstimulated or maximally inhibited) controls.
- Plot the normalized response against the **Irucalantide** concentration to determine the IC50 value.

Conclusion

The calcium mobilization and NF- κ B translocation assays are powerful, cell-based methods for characterizing the functional activity of **Irucalantide**. The calcium flux assay provides a rapid and direct measure of the immediate signaling downstream of the B2 receptor, making it ideal for high-throughput screening and potency determination. The NF- κ B translocation assay offers a more integrated view of the downstream consequences of pathway inhibition, confirming the impact on a key transcription factor involved in the inflammatory response. Together, these protocols provide a robust framework for researchers to investigate the cellular pharmacology of **Irucalantide** and other modulators of the kallikrein-kinin system.

Need Custom Synthesis?

BenchChem offers custom synthesis for rare earth carbides and specific isotopic labeling.

Email: info@benchchem.com or [Request Quote Online](#).

References

- 1. medchemexpress.com [medchemexpress.com]
- 2. go.drugbank.com [go.drugbank.com]
- 3. A modular map of Bradykinin-mediated inflammatory signaling network - PMC [pmc.ncbi.nlm.nih.gov]
- 4. researchgate.net [researchgate.net]
- 5. gosset.ai [gosset.ai]
- 6. innoprot.com [innoprot.com]
- 7. Bradykinin receptor B2 - Wikipedia [en.wikipedia.org]
- 8. Calcium Mobilization Assay to Measure the Activity of Gq-coupled Receptors [en.bio-protocol.org]

- 9. Regulation of nuclear factor kappaB activation by G-protein-coupled receptors - PubMed [pubmed.ncbi.nlm.nih.gov]
- 10. mdpi.com [mdpi.com]
- 11. Calcium Mobilization Assay to Measure the Activity of Gq-coupled Receptors [bio-protocol.org]
- 12. FLIPR Calcium Mobilization Assays in GPCR Drug Discovery | Springer Nature Experiments [experiments.springernature.com]
- 13. Intracellular Calcium Measurements with FLIPR Calcium Assay Kit [moleculardevices.com]
- 14. High-Throughput Assays to Measure Intracellular Ca²⁺ Mobilization in Cells that Express Recombinant S1P Receptor Subtypes - PMC [pmc.ncbi.nlm.nih.gov]
- 15. Nuclear Factor Kappa B (NF-κB) Translocation Assay Development and Validation for High Content Screening - Assay Guidance Manual - NCBI Bookshelf [ncbi.nlm.nih.gov]
- To cite this document: BenchChem. [Application Note: Cell-Based Assays for Characterizing Irucalantide Activity]. BenchChem, [2025]. [Online PDF]. Available at: [https://www.benchchem.com/product/b10861805#cell-based-assays-for-irucalantide-activity]

Disclaimer & Data Validity:

The information provided in this document is for Research Use Only (RUO) and is strictly not intended for diagnostic or therapeutic procedures. While BenchChem strives to provide accurate protocols, we make no warranties, express or implied, regarding the fitness of this product for every specific experimental setup.

Technical Support: The protocols provided are for reference purposes. Unsure if this reagent suits your experiment? [[Contact our Ph.D. Support Team for a compatibility check](#)]

Need Industrial/Bulk Grade? [Request Custom Synthesis Quote](#)

BenchChem

Our mission is to be the trusted global source of essential and advanced chemicals, empowering scientists and researchers to drive progress in science and industry.

Contact

Address: 3281 E Guasti Rd

Ontario, CA 91761, United States

Phone: (601) 213-4426

Email: info@benchchem.com