

An In-depth Technical Guide on the Foundational Biological Activity of TH470

Author: BenchChem Technical Support Team. **Date:** April 2026

Compound of Interest

Compound Name: TH470
Cat. No.: B10861932

[Get Quote](#)

Disclaimer: As of the latest search, public domain scientific literature does not contain specific data regarding a compound designated "**TH470**". The following document serves as a comprehensive template, illustrating the requested structure and content for a technical whitepaper on the biological activity of a novel compound. The data and experimental details provided are hypothetical and intended to serve as placeholders and examples for researchers, scientists, and drug development professionals.

Introduction

This document provides a detailed overview of the foundational biological activities of the novel investigational compound **TH470**. The primary focus of this guide is to present the core in vitro and in vivo data, detail the experimental methodologies used to generate this data, and visualize the proposed mechanism of action and experimental workflows. The intended audience for this technical guide includes researchers, scientists, and professionals involved in drug development.

Quantitative Data Summary

The biological activity of **TH470** has been quantified across a range of preclinical assays. The following tables summarize the key findings to facilitate comparison and analysis.

Table 1: In Vitro Cytotoxicity of **TH470** in Human Cancer Cell Lines

Cell Line	Cancer Type	IC50 (nM)	Assay Type
MCF-7	Breast Adenocarcinoma	150 ± 12	CellTiter-Glo®
A549	Lung Carcinoma	320 ± 25	MTT
HCT116	Colorectal Carcinoma	85 ± 9	RealTime-Glo™
PC-3	Prostate Cancer	210 ± 18	Resazurin

Table 2: Kinase Inhibition Profile of **TH470**

Kinase Target	Ki (nM)	Assay Platform
EGFR	12 ± 2	LanthaScreen™
HER2	35 ± 5	Z'-LYTE™
VEGFR2	8 ± 1	ADP-Glo™
SRC	> 1000	Kinase-Glo®

Experimental Protocols

Detailed methodologies for the key experiments are provided below to ensure reproducibility.

Cell Viability Assay (CellTiter-Glo® Luminescent Cell Viability Assay)

- **Cell Seeding:** Cancer cell lines were seeded in 96-well opaque-walled plates at a density of 5,000 cells per well in 100 µL of complete growth medium and incubated for 24 hours at 37°C, 5% CO₂.
- **Compound Treatment:** A 10 mM stock solution of **TH470** in DMSO was serially diluted in growth medium. 100 µL of the diluted compound was added to the respective wells to

achieve a final concentration range of 0.1 nM to 100 μ M. Control wells received medium with 0.1% DMSO.

- Incubation: Plates were incubated for 72 hours at 37°C, 5% CO₂.
- Lysis and Luminescence Reading: The plates were equilibrated to room temperature for 30 minutes. 100 μ L of CellTiter-Glo® Reagent was added to each well, followed by mixing on an orbital shaker for 2 minutes to induce cell lysis. The plates were then incubated at room temperature for 10 minutes to stabilize the luminescent signal.
- Data Acquisition: Luminescence was recorded using a microplate reader.
- Data Analysis: The half-maximal inhibitory concentration (IC₅₀) values were calculated by fitting the dose-response curves using a four-parameter logistic model in GraphPad Prism.

Kinase Inhibition Assay (LanthaScreen™ Eu Kinase Binding Assay)

- Reagents: All kinase assay reagents, including the Eu-anti-tag antibody, Alexa Fluor™ 647-labeled tracer, and purified kinase, were obtained from Thermo Fisher Scientific.
- Assay Procedure: The assay was performed in 384-well microplates. 2 μ L of serially diluted **TH470** in kinase buffer was added to the wells.
- Kinase and Tracer Addition: 4 μ L of a mixture containing the kinase and the Alexa Fluor™ 647-labeled tracer was added to each well.
- Antibody Addition: 4 μ L of the Eu-anti-tag antibody was added, and the plate was incubated at room temperature for 1 hour.
- Fluorescence Resonance Energy Transfer (FRET) Measurement: The time-resolved FRET (TR-FRET) signal was measured on a compatible plate reader with an excitation wavelength of 340 nm and emission wavelengths of 615 nm (Europium) and 665 nm (Alexa Fluor™ 647).
- Data Analysis: The emission ratio (665/615) was calculated, and the inhibition constant (K_i) was determined from the dose-response curve.

Visualizations: Signaling Pathways and Workflows

Visual diagrams are provided to illustrate complex biological processes and experimental designs.

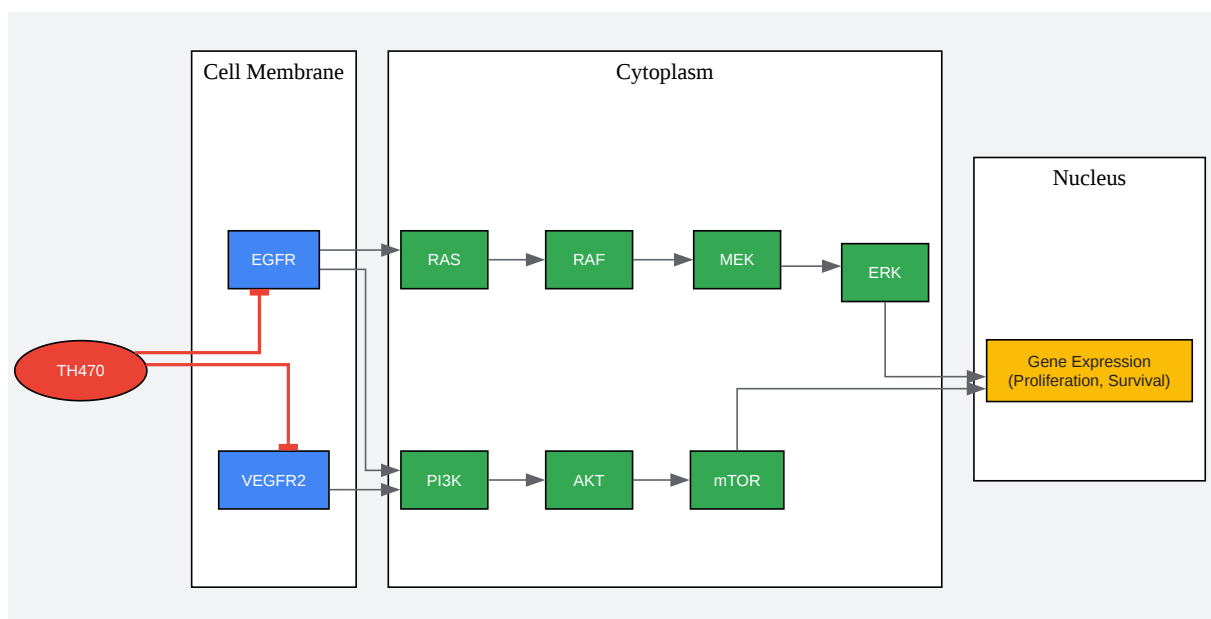

[Click to download full resolution via product page](#)

Caption: Proposed mechanism of action for **TH470**, inhibiting EGFR and VEGFR2 signaling pathways.



[Click to download full resolution via product page](#)

Caption: High-level workflow for preclinical evaluation of **TH470**.

- To cite this document: BenchChem. [An In-depth Technical Guide on the Foundational Biological Activity of TH470]. BenchChem, [2026]. [Online PDF]. Available at: [<https://www.benchchem.com/product/b10861932/docs#an-in-depth-technical-guide-on-the-foundational-biological-activity-of-th470>]

Disclaimer & Data Validity:

The information provided in this document is for Research Use Only (RUO) and is strictly not intended for diagnostic or therapeutic procedures. While BenchChem strives to provide accurate protocols, we make no warranties, express or implied, regarding the fitness of this product for every specific experimental setup.

Technical Support: The protocols provided are for reference purposes. Unsure if this reagent suits your experiment?

Need Industrial/Bulk Grade? [Request Custom Synthesis Quote](#)

BenchChem

Our mission is to be the trusted global source of essential and advanced chemicals, empowering scientists and researchers to drive progress in science and industry.

Contact

Address: 3281 E Guasti Rd
Ontario, CA 91761, United States
Phone: (601) 213-4426
Email: info@benchchem.com

[Contact our Ph.D. Support Team for a compatibility check](#)