

# Confirming ALK4290 On-Target Effects with siRNA: A Comparative Guide

**Author:** BenchChem Technical Support Team. **Date:** April 2026

## Compound of Interest

Compound Name: ALK4290 dihydrochloride

CAS No.: 1372127-19-9

Cat. No.: B10860155

[Get Quote](#)

For Researchers, Scientists, and Drug Development Professionals

This guide provides a comparative framework for validating the on-target effects of ALK4290, a C-C chemokine receptor type 3 (CCR3) antagonist, using small interfering RNA (siRNA). While direct experimental data on the use of siRNA for ALK4290 is not publicly available, this document outlines a standard methodology and expected outcomes based on its known mechanism of action. We also compare this approach with other target validation methods.

## ALK4290: Mechanism of Action

ALK4290, also known as AKST4290, is an orally administered small molecule inhibitor of the CCR3 receptor.[1] This receptor is a key component in inflammatory and angiogenic pathways. Its natural ligand, eotaxin (CCL11), is implicated in the pathogenesis of age-related diseases, including neovascular (wet) age-related macular degeneration (nAMD).[1] By blocking the interaction of eotaxin with CCR3, ALK4290 aims to reduce inflammation and inhibit the abnormal blood vessel growth (neovascularization) that are hallmarks of wet AMD.[1]

## On-Target Validation using siRNA

To confirm that the observed therapeutic effects of ALK4290 are indeed due to its interaction with CCR3, a common and effective strategy is to use siRNA to silence the gene encoding CCR3.[2][3] The rationale is that if ALK4290's effects are on-target, then the specific knockdown of CCR3 should phenocopy, or replicate, the biological effects of the drug.

## Comparative Data: Expected Outcomes

The following table summarizes the expected comparative outcomes from treating relevant cells (e.g., human retinal microvascular endothelial cells) with ALK4290 versus a CCR3-targeting siRNA.

Parameter	Control (Vehicle/Scrambled siRNA)	ALK4290 Treatment	CCR3 siRNA Treatment	Interpretation of Concordance
CCR3 mRNA Expression	100%	~100%	<20%	Confirms siRNA efficacy.
CCR3 Protein Level	100%	~100%	<20%	Confirms siRNA efficacy.
Eotaxin-induced Cell Migration	High	Low	Low	Concordant results suggest on-target effect on cell migration.
VEGF-induced Tube Formation	High	Low	Low	Concordant results suggest on-target effect on angiogenesis.
Downstream Signaling (e.g., p-ERK)	High	Low	Low	Concordant results confirm on-target pathway inhibition.

## Experimental Protocols

Below are detailed methodologies for key experiments to validate the on-target effects of ALK4290 using siRNA.

## Cell Culture and Reagents

- Cells: Human Retinal Microvascular Endothelial Cells (HRMEC) are a suitable in vitro model.
- Culture Medium: Endothelial Cell Growth Medium supplemented with growth factors.
- ALK4290: Dissolved in a suitable solvent (e.g., DMSO) to create a stock solution.
- siRNA: Pre-designed and validated siRNA targeting CCR3 and a non-targeting (scrambled) control siRNA.
- Transfection Reagent: A lipid-based transfection reagent suitable for endothelial cells.

## siRNA Transfection

- Plate HRMECs at a density that will result in 50-60% confluency at the time of transfection.
- Prepare the siRNA-lipid complexes according to the transfection reagent manufacturer's protocol. A final siRNA concentration of 10-20 nM is typically effective.
- Add the complexes to the cells and incubate for 24-48 hours.
- After incubation, cells can be used for downstream assays or treated with ALK4290.

## Quantitative PCR (qPCR) for CCR3 mRNA Expression

- Extract total RNA from transfected cells using a suitable kit.
- Synthesize cDNA from the RNA using a reverse transcription kit.
- Perform qPCR using primers specific for CCR3 and a housekeeping gene (e.g., GAPDH) for normalization.
- Calculate the relative expression of CCR3 mRNA using the  $\Delta\Delta C_t$  method.

## Western Blot for CCR3 Protein Expression

- Lyse transfected cells and quantify total protein concentration.
- Separate protein lysates by SDS-PAGE and transfer to a PVDF membrane.
- Probe the membrane with a primary antibody against CCR3, followed by a secondary antibody conjugated to HRP.
- Detect the signal using a chemiluminescent substrate. Use an antibody against a loading control (e.g.,  $\beta$ -actin) for normalization.

## Cell Migration Assay (Boyden Chamber)

- After siRNA transfection or pre-treatment with ALK4290, detach and resuspend HRMECs in a serum-free medium.
- Place the cell suspension in the upper chamber of a Boyden chamber insert.
- Add medium containing eotaxin as a chemoattractant to the lower chamber.
- Incubate for 4-6 hours to allow for cell migration through the porous membrane.
- Fix, stain, and count the migrated cells on the lower surface of the membrane.

## Tube Formation Assay

- Coat a 96-well plate with a basement membrane matrix (e.g., Matrigel).
- Seed HRMECs (previously transfected with siRNA or treated with ALK4290) onto the matrix.
- Incubate for 6-12 hours to allow for the formation of capillary-like structures.
- Image the tube networks and quantify parameters such as total tube length and number of branch points using imaging software.

## Visualizing Pathways and Workflows

### ALK4290 Signaling Pathway

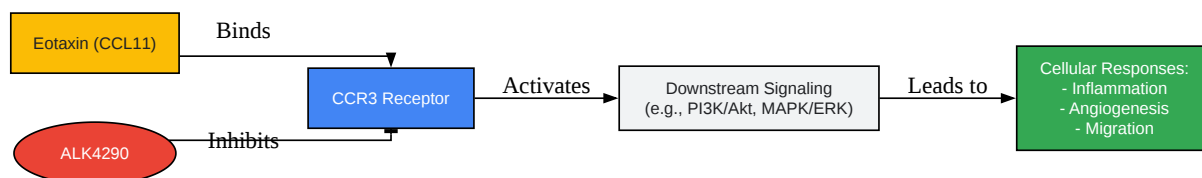

[Click to download full resolution via product page](#)

Caption: ALK4290 inhibits the binding of eotaxin to the CCR3 receptor.

## Experimental Workflow for On-Target Validation

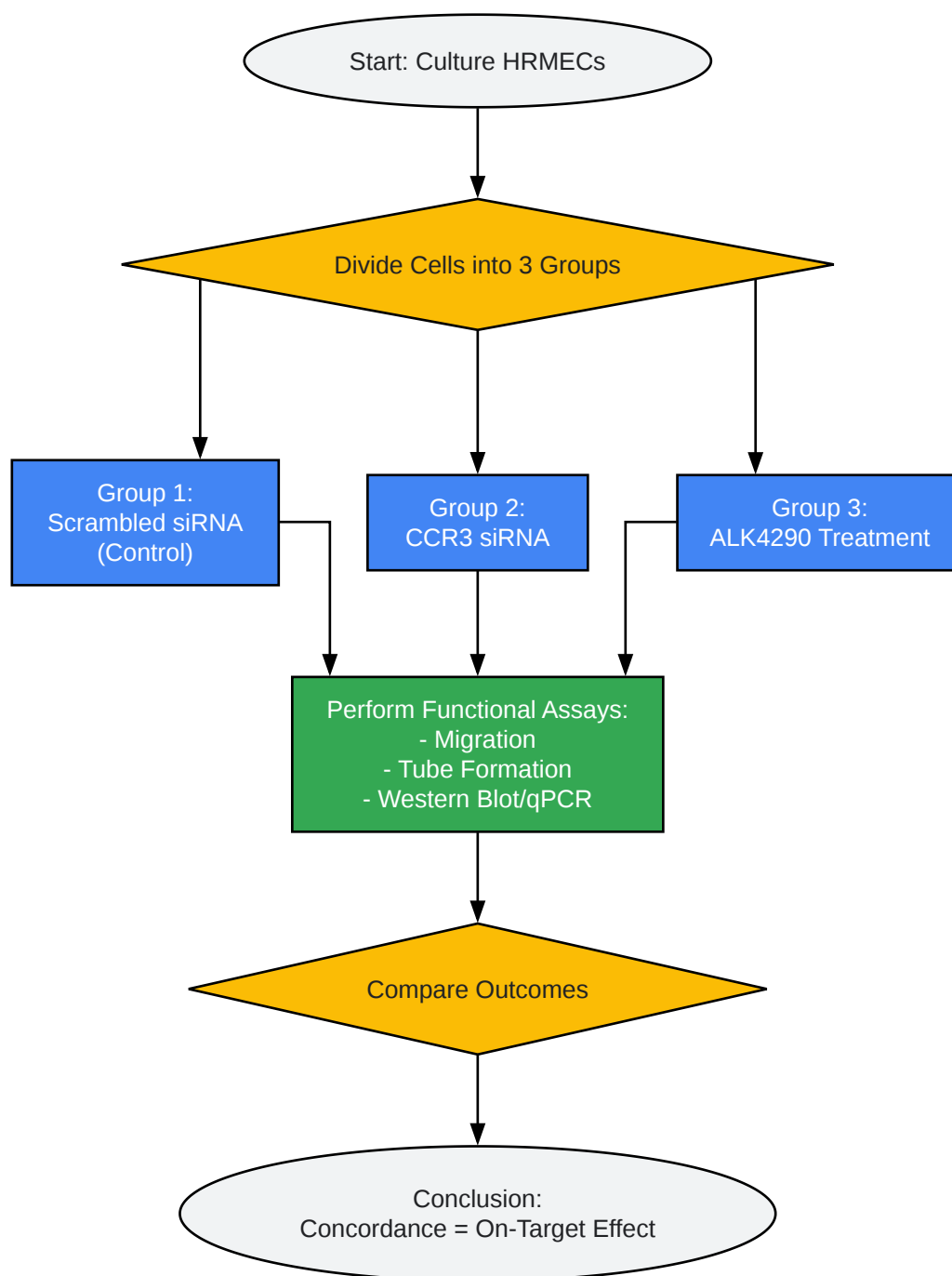

[Click to download full resolution via product page](#)

Caption: Workflow for comparing ALK4290 effects to CCR3 siRNA knockdown.

## Alternative Methods for On-Target Validation

While siRNA is a powerful tool, a multi-faceted approach to target validation is often the most robust.

Method	Principle	Advantages	Disadvantages
CRISPR/Cas9 Gene Knockout	Permanent disruption of the target gene (CCR3).	Complete loss of function; stable cell lines.	Potential for off-target gene editing; more time-consuming.
Rescue Experiments	Re-expressing the target protein in a knockout/knockdown background to see if the drug effect is reversed.	Strongly demonstrates target specificity.	Technically challenging; requires expression vectors.
Cellular Thermal Shift Assay (CETSA)	Measures the change in thermal stability of a target protein upon ligand (drug) binding.	Direct evidence of drug-target engagement in a cellular context.	Requires specific antibodies; may not be suitable for all targets.
Biotinylated Drug Pulldown	Uses a modified version of the drug to pull down its binding partners from cell lysates.	Can identify direct binding partners.	Drug modification may alter binding affinity; potential for non-specific binding.

## Comparison of Target Validation Methods

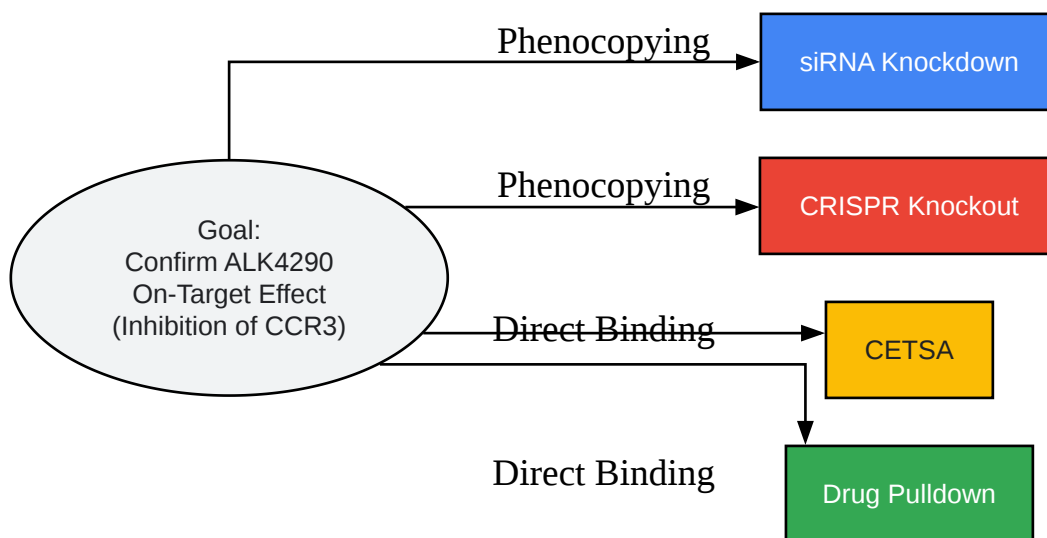

[Click to download full resolution via product page](#)

Caption: Different approaches to validate the on-target effects of ALK4290.

By employing siRNA-mediated gene silencing and comparing the results to those of ALK4290 treatment, researchers can build a strong case for the on-target mechanism of this drug candidate. Combining this with alternative validation methods will provide the highest level of confidence in the drug's mode of action.

### *Need Custom Synthesis?*

*BenchChem offers custom synthesis for rare earth carbides and specific isotopic labeling.*

*Email: [info@benchchem.com](mailto:info@benchchem.com) or [Request Quote Online](#).*

## References

- [1. Alkahest Presents Positive Phase 2a Study Results of AKST4290 for Treatment-Naïve Wet AMD - - Modern Optometry \[modernod.com\]](#)
- [2. Harnessing in vivo siRNA delivery for drug discovery and therapeutic development - PMC \[pmc.ncbi.nlm.nih.gov\]](#)
- [3. siRNAs in drug discovery: target validation and beyond - PubMed \[pubmed.ncbi.nlm.nih.gov\]](#)
- To cite this document: BenchChem. [Confirming ALK4290 On-Target Effects with siRNA: A Comparative Guide]. BenchChem, [2026]. [Online PDF]. Available at: [<https://www.benchchem.com/product/b10860155/docs#confirming-alk4290-on-target-effects-with-sirna-a-comparative-guide>]

---

### **Disclaimer & Data Validity:**

The information provided in this document is for Research Use Only (RUO) and is strictly not intended for diagnostic or therapeutic procedures. While BenchChem strives to provide accurate protocols, we make no warranties, express or implied, regarding the fitness of this product for every specific experimental setup.

**Technical Support:** The protocols provided are for reference purposes. Unsure if this reagent suits your experiment?

**Need Industrial/Bulk Grade?** [Request Custom Synthesis Quote](#)

## BenchChem

Our mission is to be the trusted global source of essential and advanced chemicals, empowering scientists and researchers to drive progress in science and industry.

### Contact

Address: 3281 E Guasti Rd  
Ontario, CA 91761, United States  
Phone: (601) 213-4426  
Email: [info@benchchem.com](mailto:info@benchchem.com)

[Contact our Ph.D. Support Team for a compatibility check](#)