

# Application Notes and Protocols: Assessing PSMA Receptor Density with Flotufolastat F-18

**Author:** BenchChem Technical Support Team. **Date:** April 2026

## Compound of Interest

Compound Name: Flotufolastat F-18

CAS No.: 2639294-14-5

Cat. No.: B10860806

[Get Quote](#)

For Researchers, Scientists, and Drug Development Professionals

## Introduction

**Flotufolastat F-18** (formerly known as  $^{18}\text{F}$ -rhPSMA-7.3, and commercially available as Posluma®) is a high-affinity, radiohybrid, prostate-specific membrane antigen (PSMA)-targeted positron emission tomography (PET) imaging agent.[1][2] It is indicated for the PET imaging of PSMA-positive lesions in men with prostate cancer.[2][3] The overexpression of PSMA on the surface of prostate cancer cells makes it an exceptional biomarker for disease detection and staging.[4] **Flotufolastat F-18** binds with high specificity to the extracellular domain of the PSMA protein, allowing for the in vivo quantification and visualization of PSMA receptor density.[2] This document provides detailed application notes and protocols for utilizing **Flotufolastat F-18** in preclinical and clinical research settings to assess PSMA receptor density.

## Mechanism of Action and Signaling Pathway

**Flotufolastat F-18** is a radiopharmaceutical that targets PSMA, a transmembrane glycoprotein highly expressed on prostate cancer cells.[2] The molecule consists of a PSMA-binding moiety linked to the positron-emitting isotope Fluorine-18.[5] Upon intravenous administration,

**Flotufolastat F-18** circulates in the bloodstream and binds to PSMA-expressing cells.[2] This binding leads to the internalization of the radiotracer-receptor complex.[2] The radioactive decay of  $^{18}\text{F}$  emits positrons, which, after annihilating with electrons in the surrounding tissue, produce two 511 keV gamma photons that are detected by a PET scanner.[6] The resulting image provides a quantitative map of **Flotufolastat F-18** distribution, which directly correlates with PSMA receptor density.

Recent research has elucidated the role of PSMA in cellular signaling. PSMA expression is linked to the activation of the PI3K-AKT-mTOR pathway, a critical signaling cascade for cell survival and proliferation.[7][8] PSMA appears to redirect signaling from the MAPK pathway to the PI3K-AKT pathway, thereby promoting a pro-survival phenotype in prostate cancer cells.[8] [9] This interaction is mediated through PSMA's association with the scaffolding protein RACK1 and its influence on the  $\beta$ 1-integrin and IGF-1R signaling complex.[8][9]

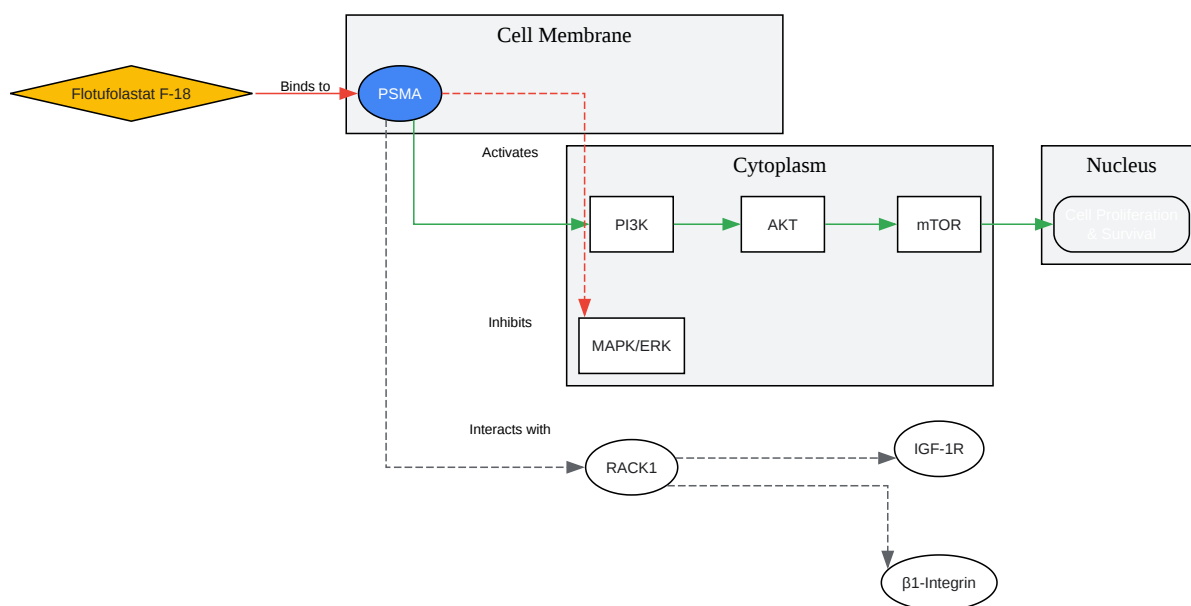

[Click to download full resolution via product page](#)

**Caption: Flotufolastat F-18** binding to PSMA and its influence on downstream signaling pathways.

## Quantitative Data Presentation

The biodistribution of **Flotufolastat F-18** has been characterized in clinical trials, providing valuable data on its uptake in various organs. The following tables summarize the quantitative data from a post hoc analysis of the LIGHTHOUSE and SPOTLIGHT studies.[8] Standardized Uptake Values (SUV) are used to quantify the tracer uptake, with SUVmean representing the average uptake within a volume of interest and SUVpeak representing the highest average uptake in a small, defined volume.

Table 1: **Flotufolastat F-18** Biodistribution in Normal Organs (Mean  $\pm$  SD)[8]

Organ	SUVmean (Mean $\pm$ SD)	SUVpeak (Mean $\pm$ SD)
Liver	6.7 $\pm$ 1.7	8.2 $\pm$ 2.1
Kidneys	22.4 $\pm$ 5.5	37.8 $\pm$ 9.0
Spleen	9.8 $\pm$ 8.8	-
Blood Pool	2.1	-
Lungs	0.8	-
Bone	1.6	-
Muscle	0.8	-

Table 2: **Flotufolastat F-18** Biodistribution in Normal Organs (Median [IQR])[8]

Organ	SUVmean (Median [IQR])	SUVpeak (Median [IQR])
Bladder	10.6 [11.9]	16.0 [18.5]

## Experimental Protocols

## In Vitro Protocols

### 1. Competitive Radioligand Binding Assay

This assay determines the binding affinity ( $IC_{50}$  and  $K_i$ ) of **Flotufolastat F-18** to PSMA-expressing cells.

- Cell Lines: LNCaP (PSMA-positive) and PC-3 (PSMA-negative) cell lines are recommended.
- Materials:
  - **Flotufolastat F-18**
  - Unlabeled Flotufolastat or another high-affinity PSMA inhibitor (e.g., 2-PMPA)
  - LNCaP and PC-3 cells
  - Binding buffer (e.g., Tris-HCl with  $MgCl_2$ )
  - 96-well filter plates
  - Gamma counter
- Procedure:
  - Prepare cell membranes from LNCaP and PC-3 cells.
  - In a 96-well plate, add a fixed concentration of **Flotufolastat F-18** to each well.
  - Add increasing concentrations of the unlabeled competitor.
  - Add the cell membrane preparation to each well.
  - Incubate at 37°C for 1 hour.
  - Rapidly filter the contents of each well and wash with cold binding buffer.
  - Measure the radioactivity of the filters using a gamma counter.

- Plot the percentage of specific binding against the log concentration of the competitor to determine the IC<sub>50</sub> value.

## 2. Cellular Uptake and Internalization Assay

This assay quantifies the cellular uptake and internalization of **Flotufolastat F-18**.

- Cell Lines: LNCaP and PC-3 cells.
- Materials:
  - **Flotufolastat F-18**
  - Cell culture medium
  - Acid wash buffer (e.g., glycine buffer, pH 2.8)
  - Lysis buffer (e.g., NaOH)
  - Gamma counter
- Procedure:
  - Seed LNCaP and PC-3 cells in 24-well plates and allow them to adhere.
  - Add a known concentration of **Flotufolastat F-18** to each well and incubate at 37°C for various time points (e.g., 15, 30, 60, 120 minutes).
  - To determine surface-bound versus internalized radioactivity, at each time point:
    - Wash the cells with ice-cold PBS.
    - Incubate with acid wash buffer for 5-10 minutes on ice to strip surface-bound radiotracer. Collect this fraction.
    - Lyse the cells with lysis buffer to release the internalized radiotracer. Collect this fraction.
  - Measure the radioactivity in both fractions using a gamma counter.

- Calculate the percentage of total added radioactivity for both surface-bound and internalized fractions.

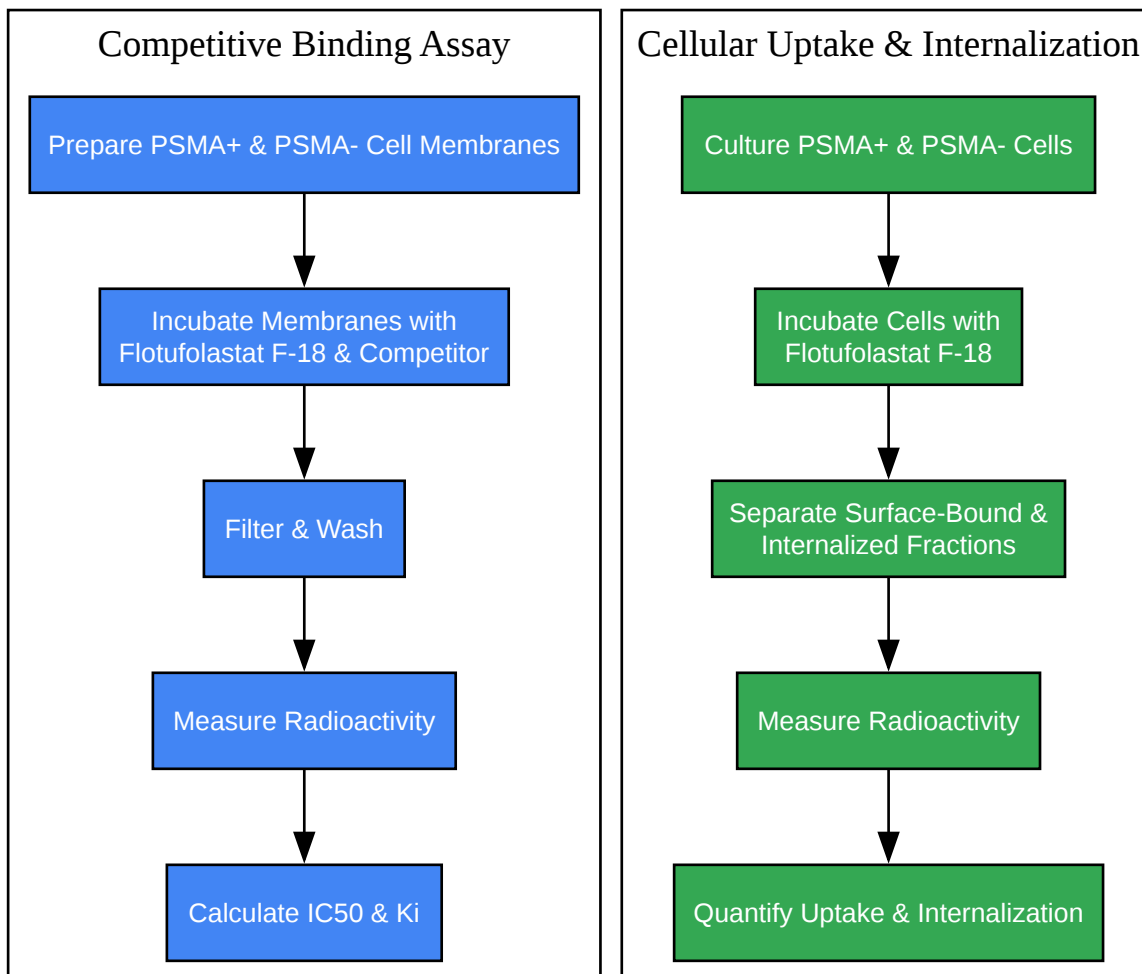

[Click to download full resolution via product page](#)

**Caption:** Workflow for in vitro assessment of **Flotufolastat F-18** binding and uptake.

## In Vivo and Ex Vivo Protocols

### 1. Preclinical PET/CT Imaging in a Xenograft Mouse Model

This protocol outlines the procedure for in vivo imaging of **Flotufolastat F-18** in a mouse model bearing prostate cancer xenografts.

- Animal Model: Male immunodeficient mice (e.g., NOD-SCID) bearing subcutaneous LNCaP (PSMA-positive) and PC-3 (PSMA-negative) tumors.

- Materials:
  - **Flotufolastat F-18**
  - Anesthesia (e.g., isoflurane)
  - Small animal PET/CT scanner
- Procedure:
  - Anesthetize the tumor-bearing mouse.
  - Administer a defined dose of **Flotufolastat F-18** (e.g., 5-10 MBq) via tail vein injection.
  - Perform dynamic or static PET/CT imaging at specified time points post-injection (e.g., 30, 60, 120 minutes).
  - Reconstruct the PET images and co-register with the CT images.
  - Draw regions of interest (ROIs) over the tumors and major organs to calculate SUVmean and SUVmax.

## 2. Ex Vivo Autoradiography

This technique provides high-resolution visualization of **Flotufolastat F-18** distribution in tissue sections.

- Tissue Samples: Frozen sections of prostate tumor tissue from xenograft models or human biopsies.
- Materials:
  - **Flotufolastat F-18**
  - Binding buffer
  - Phosphor imaging plates or autoradiography film
- Procedure:

- Cut thin (e.g., 20  $\mu\text{m}$ ) frozen tissue sections and mount them on microscope slides.
- Incubate the sections with a solution containing **Flotufolastat F-18**.
- For non-specific binding, incubate adjacent sections with **Flotufolastat F-18** and an excess of an unlabeled PSMA inhibitor.
- Wash the slides to remove unbound radiotracer.
- Expose the dried slides to a phosphor imaging plate or autoradiography film.
- Scan the plate or develop the film to visualize the distribution of radioactivity.

## Clinical PET/CT Protocol

This protocol is based on the methodology used in the LIGHTHOUSE and SPOTLIGHT clinical trials.[7]

- Patient Preparation:
  - Patients should be well-hydrated.
  - Patients should void immediately before PET scanner acquisition.
- Radiopharmaceutical Administration:
  - Administer a target activity of 296 MBq (8 mCi) of **Flotufolastat F-18** as an intravenous injection.
- Image Acquisition:
  - Initiate PET/CT imaging 50 to 70 minutes after the injection.
  - Acquire images from mid-thigh to the base of the skull.
  - The acquisition time per bed position is typically 3 minutes.
- Image Analysis:

- Reconstruct PET images using standard iterative reconstruction algorithms.
- Calculate SUVmean and SUVpeak for regions of interest corresponding to suspected lesions and normal organs.

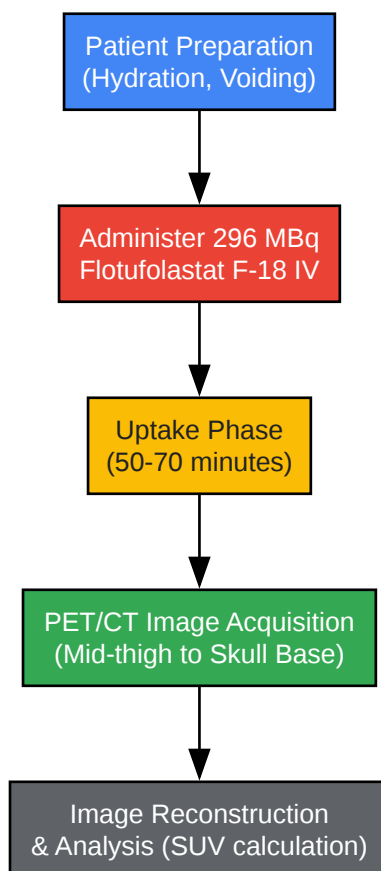

[Click to download full resolution via product page](#)

**Caption:** Clinical workflow for PET/CT imaging with **Flutufolastat F-18**.

## Conclusion

**Flutufolastat F-18** is a powerful tool for the non-invasive assessment of PSMA receptor density in both preclinical and clinical settings. The quantitative data derived from **Flutufolastat F-18** PET imaging can provide valuable insights into tumor biology, aid in patient selection for PSMA-targeted therapies, and serve as a biomarker for treatment response. The protocols outlined in these application notes provide a framework for the effective use of **Flutufolastat F-18** in prostate cancer research and drug development.

**Need Custom Synthesis?**

BenchChem offers custom synthesis for rare earth carbides and specific isotopic labeling.

Email: [info@benchchem.com](mailto:info@benchchem.com) or [Request Quote Online](#).

## References

- [1. Low-Level Endogenous PSMA Expression in Nonprostatic Tumor Xenografts Is Sufficient for In Vivo Tumor Targeting and Imaging - PMC \[pmc.ncbi.nlm.nih.gov\]](#)
- [2. jnm.snmjournals.org \[jnm.snmjournals.org\]](#)
- [3. researchgate.net \[researchgate.net\]](#)
- [4. researchgate.net \[researchgate.net\]](#)
- [5. Heterogeneous PSMA expression on circulating tumor cells - a potential basis for stratification and monitoring of PSMA-directed therapies in prostate cancer - PMC \[pmc.ncbi.nlm.nih.gov\]](#)
- [6. pubs.acs.org \[pubs.acs.org\]](#)
- [7. Preclinical Evaluation of a Companion Diagnostic Radiopharmaceutical, \[18F\]PSMA-1007, in a Subcutaneous Prostate Cancer Xenograft Mouse Model - PMC \[pmc.ncbi.nlm.nih.gov\]](#)
- [8. aacrjournals.org \[aacrjournals.org\]](#)
- [9. researchgate.net \[researchgate.net\]](#)
- To cite this document: BenchChem. [Application Notes and Protocols: Assessing PSMA Receptor Density with Flutufolastat F-18]. BenchChem, [2026]. [Online PDF]. Available at: [\[https://www.benchchem.com/product/b10860806/docs#application-notes-and-protocols-assessing-psma-receptor-density-with-flutufolastat-f-18\]](https://www.benchchem.com/product/b10860806/docs#application-notes-and-protocols-assessing-psma-receptor-density-with-flutufolastat-f-18)

---

### Disclaimer & Data Validity:

The information provided in this document is for Research Use Only (RUO) and is strictly not intended for diagnostic or therapeutic procedures. While BenchChem strives to provide accurate protocols, we make no warranties, express or implied, regarding the fitness of this product for every specific experimental setup.

**Technical Support:** The protocols provided are for reference purposes. Unsure if this reagent suits your experiment?

**Need Industrial/Bulk Grade?** [Request Custom Synthesis Quote](#)

## BenchChem

Our mission is to be the trusted global source of essential and advanced chemicals, empowering scientists and researchers to drive progress in science and industry.

### Contact

Address: 3281 E Guasti Rd  
Ontario, CA 91761, United States  
Phone: (601) 213-4426  
Email: [info@benchchem.com](mailto:info@benchchem.com)

[Contact our Ph.D. Support Team for a compatibility check](#)