

avoiding degradation of Z16078526 in solution

Author: BenchChem Technical Support Team. **Date:** April 2026

Compound of Interest

Compound Name: Z16078526

Cat. No.: B10857422

[Get Quote](#)

Technical Support Center: Compound Z16078526

This technical support center provides guidance for researchers, scientists, and drug development professionals on how to avoid the degradation of compound **Z16078526** in solution.

Frequently Asked Questions (FAQs)

Q1: What are the primary factors that can cause the degradation of **Z16078526** in solution?

A1: The stability of **Z16078526** in solution can be influenced by several factors, including:

- pH: The compound may be susceptible to acid or base-catalyzed hydrolysis.
- Temperature: Elevated temperatures can accelerate degradation kinetics.
- Light: Exposure to light, particularly UV light, can induce photolytic degradation.
- Oxidation: The presence of oxygen or other oxidizing agents can lead to oxidative degradation.

- Solvent: The choice of solvent can impact stability, with protic solvents sometimes participating in degradation reactions.

Q2: How can I assess the stability of my **Z16078526** solution?

A2: A stability-indicating analytical method, such as High-Performance Liquid Chromatography (HPLC) or Liquid Chromatography-Mass Spectrometry (LC-MS), is essential. This involves monitoring the concentration of the parent compound and the appearance of any degradation products over time under various stress conditions (e.g., different pH, temperature, and light exposure).

Q3: What are the recommended storage conditions for **Z16078526** solutions?

A3: While specific conditions depend on the compound's inherent stability, general recommendations for preserving the integrity of **Z16078526** solutions include:

- Storage Temperature: Store solutions at low temperatures, typically 2-8°C or -20°C, to minimize thermal degradation.
- Light Protection: Protect solutions from light by using amber vials or by wrapping containers in aluminum foil.
- Inert Atmosphere: For oxygen-sensitive compounds, purging the solution and vial headspace with an inert gas like nitrogen or argon can prevent oxidative degradation.

Troubleshooting Guide

This guide addresses common issues encountered during the handling and analysis of **Z16078526** solutions.

Observed Issue	Potential Cause	Recommended Action
Rapid loss of parent compound peak in HPLC analysis.	Chemical degradation.	Perform a forced degradation study to identify the degradation pathway (see Experimental Protocols). Adjust solution pH, protect from light, or store at a lower temperature.
Appearance of new peaks in the chromatogram.	Formation of degradation products.	Characterize the degradation products using LC-MS or other suitable analytical techniques. This can provide insights into the degradation mechanism.
Inconsistent results between experiments.	Instability of stock or working solutions.	Prepare fresh solutions for each experiment. If solutions must be stored, validate their stability over the intended storage period.
Precipitation of the compound from solution.	Poor solubility or solvent evaporation.	Ensure the chosen solvent has adequate solubilizing power for Z16078526. Store solutions in tightly sealed containers to prevent solvent evaporation.

Experimental Protocols

Protocol 1: Forced Degradation Study

This protocol outlines a systematic approach to identify the degradation pathways of **Z16078526**.

Objective: To determine the intrinsic stability of **Z16078526** and to develop a stability-indicating analytical method.

Methodology:

- Prepare Stock Solution: Prepare a stock solution of **Z16078526** in a suitable solvent (e.g., acetonitrile or DMSO) at a known concentration (e.g., 1 mg/mL).
- Stress Conditions: Subject aliquots of the stock solution to the following stress conditions:
 - Acid Hydrolysis: Add 0.1 N HCl and incubate at 60°C for 24 hours.
 - Base Hydrolysis: Add 0.1 N NaOH and incubate at 60°C for 24 hours.
 - Oxidative Degradation: Add 3% hydrogen peroxide and incubate at room temperature for 24 hours.
 - Thermal Degradation: Incubate at 60°C for 24 hours.
 - Photolytic Degradation: Expose to UV light (e.g., 254 nm) for 24 hours.
- Sample Analysis: Analyze the stressed samples, along with an unstressed control sample, by a stability-indicating HPLC-UV or LC-MS method.
- Data Evaluation: Compare the chromatograms of the stressed samples to the control. Identify and quantify the degradation products. The goal is to achieve 5-20% degradation of the parent compound.

Data Presentation: Summary of Forced Degradation Results (Hypothetical Data)

Stress Condition	% Degradation of Z16078526	Number of Degradation Products
0.1 N HCl, 60°C, 24h	15.2%	2
0.1 N NaOH, 60°C, 24h	25.8%	3
3% H ₂ O ₂ , RT, 24h	8.5%	1
60°C, 24h	5.1%	1
UV Light (254 nm), 24h	18.9%	2
Control	<1%	0

Visualizations

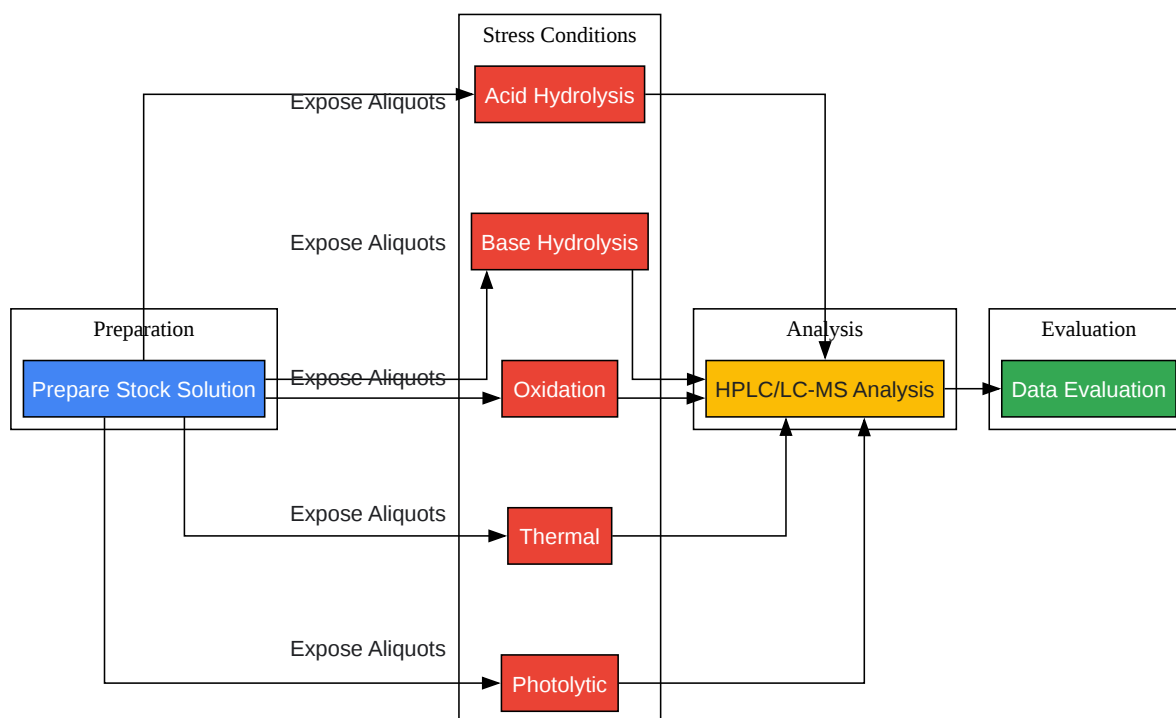

[Click to download full resolution via product page](#)

Caption: Workflow for a forced degradation study of **Z16078526**.

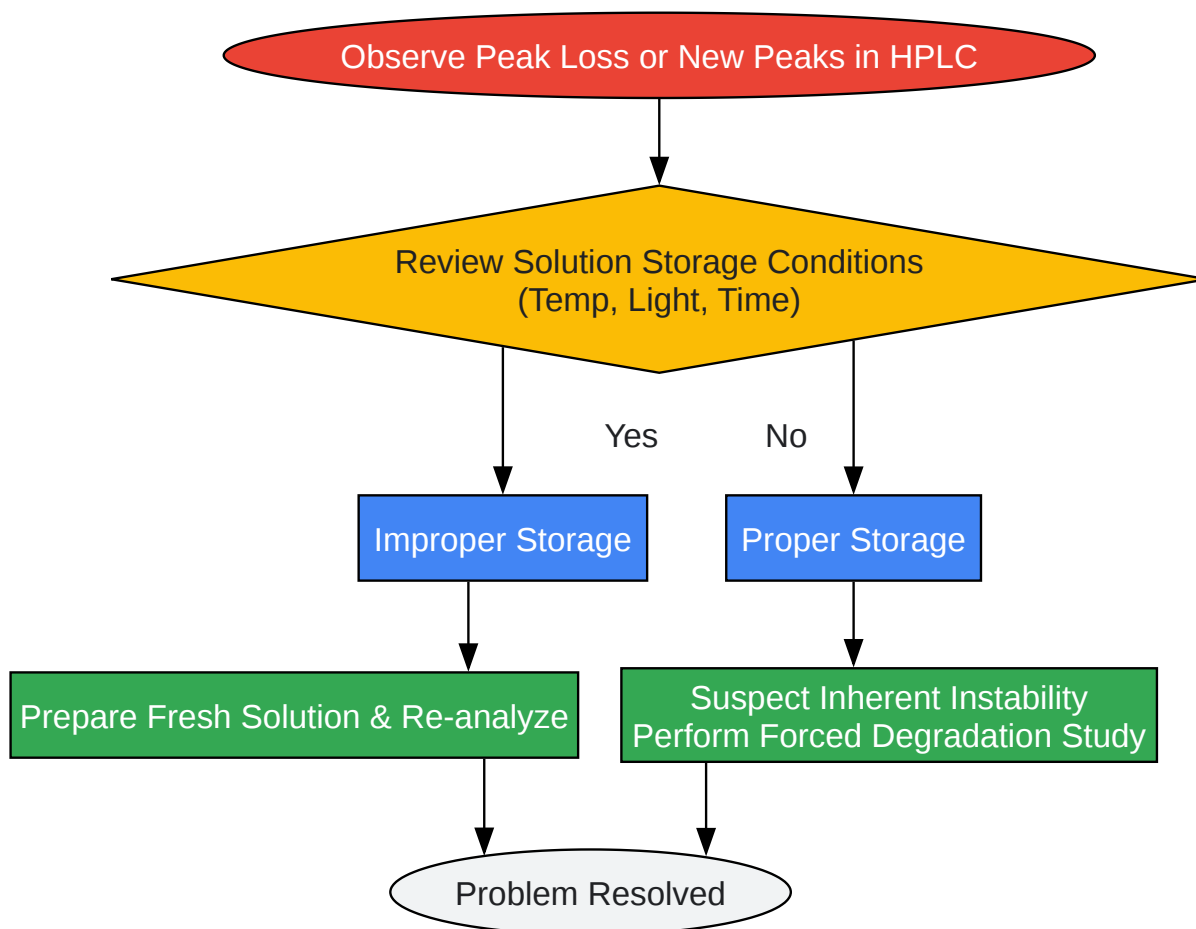

[Click to download full resolution via product page](#)

Caption: Troubleshooting logic for HPLC instability issues of **Z16078526**.

- To cite this document: BenchChem. [avoiding degradation of Z16078526 in solution]. BenchChem, [2026]. [Online PDF]. Available at: [<https://www.benchchem.com/product/b10857422/docs#avoiding-degradation-of-z16078526-in-solution>]

Disclaimer & Data Validity:

The information provided in this document is for Research Use Only (RUO) and is strictly not intended for diagnostic or therapeutic procedures. While BenchChem strives to provide

accurate protocols, we make no warranties, express or implied, regarding the fitness of this product for every specific experimental setup.

Technical Support: The protocols provided are for reference purposes. Unsure if this reagent suits your experiment?

Need Industrial/Bulk Grade? [Request Custom Synthesis Quote](#)

BenchChem

Our mission is to be the trusted global source of essential and advanced chemicals, empowering scientists and researchers to drive progress in science and industry.

Contact

Address: 3281 E Guasti Rd
Ontario, CA 91761, United States
Phone: (601) 213-4426
Email: info@benchchem.com

[Contact our Ph.D. Support Team for a compatibility check](#)