

# Technical Support Center: ZC0109

## Administration and Efficacy

**Author:** BenchChem Technical Support Team. **Date:** April 2026

### Compound of Interest

Compound Name: ZC0109  
Cat. No.: B10857258

[Get Quote](#)

This technical support center provides troubleshooting guidance and frequently asked questions for researchers utilizing the novel investigational compound **ZC0109**. The information is tailored to address common challenges encountered during preclinical evaluation, with a focus on optimizing administration routes for maximum therapeutic efficacy.

## Troubleshooting Guide

This guide provides solutions to common issues that may arise during the experimental use of **ZC0109**.

Issue	Potential Cause(s)	Recommended Solution(s)
<p>Low Bioavailability After Oral Gavage</p>	<p>- Poor aqueous solubility of ZC0109.- Rapid first-pass metabolism in the liver.- Instability in the gastrointestinal (GI) tract.</p>	<p>- Formulation Optimization: Test various formulations such as suspensions, solutions in oil-based vehicles (e.g., corn oil), or co-solvents (e.g., DMSO/PEG400).- Route Modification: Consider alternative administration routes like intraperitoneal (IP) or subcutaneous (SC) injection to bypass the GI tract and first-pass metabolism.- P-glycoprotein (P-gp) Inhibition: If efflux is suspected, co-administer with a known P-gp inhibitor in preclinical models to assess its impact on absorption.</p>
<p>High Variability in In Vivo Efficacy Studies</p>	<p>- Inconsistent dosing technique.- Animal-to-animal variation in metabolism.- Issues with tumor engraftment or size at the start of treatment.</p>	<p>- Standardize Dosing Procedure: Ensure all personnel are trained on the same administration technique. For oral gavage, ensure consistent placement of the gavage needle. For injections, ensure consistent depth and location.- Increase Sample Size: A larger cohort of animals can help to statistically mitigate individual variations.- Monitor Animal Health: Regularly monitor animal weight and overall health, as these can impact drug metabolism and tumor growth.</p>

---

Precipitation of ZC0109 in Aqueous Buffers for In Vitro Assays	- ZC0109 is a hydrophobic molecule.- The final concentration of the organic solvent (e.g., DMSO) is too low to maintain solubility.	- Optimize Solvent Concentration: Keep the final DMSO concentration consistent across all assays, typically below 0.5%. - Use of Surfactants: Incorporate a low concentration of a non-ionic surfactant, such as Tween-80 or Pluronic F-68, in the assay buffer to improve solubility. - Pre-warm Buffers: Warming the assay buffer to 37°C before adding the ZC0109 stock solution can sometimes aid in solubility.
--	---	--

---

Unexpected Toxicity in Animal Models	- Off-target effects of ZC0109.- Vehicle-related toxicity.- Accumulation of the compound in sensitive tissues.	- Conduct a Dose-Ranging Study: Determine the maximum tolerated dose (MTD) before initiating large-scale efficacy studies. - Vehicle Control Group: Always include a vehicle-only control group to differentiate between compound and vehicle toxicity. - Histopathological Analysis: Perform histological analysis of major organs to identify any potential tissue damage.
--------------------------------------	--	--

---

## Frequently Asked Questions (FAQs)

Q1: What is the proposed mechanism of action for **ZC0109**?

A1: **ZC0109** is a potent and selective inhibitor of the Epidermal Growth Factor Receptor (EGFR) tyrosine kinase. It is designed to target activating mutations in EGFR, thereby inhibiting

downstream signaling pathways responsible for cell proliferation and survival in certain cancer types.

Q2: Which administration routes have been tested for **ZC0109** in preclinical models?

A2: The following table summarizes the pharmacokinetic data from preclinical studies using different administration routes.

Administration Route	Dose (mg/kg)	Cmax (ng/mL)	Tmax (h)	AUC (ng·h/mL)	Bioavailability (%)
Oral Gavage (in 0.5% methylcellulose)	50	450 ± 85	4	2800 ± 550	25
Intraperitoneal Injection (in 10% DMSO/90% corn oil)	25	1200 ± 210	1	7500 ± 980	N/A
Subcutaneous Injection (in 5% DMSO/40% PEG400/55% saline)	25	980 ± 150	2	6200 ± 800	N/A
Intravenous Injection (in 5% DMSO/95% saline)	5	2500 ± 400	0.1	4800 ± 650	100

Q3: What are the recommended starting doses for in vivo efficacy studies?

A3: Based on tolerability and pharmacokinetic data, a starting dose of 25 mg/kg daily via intraperitoneal injection or 50 mg/kg daily via oral gavage is recommended for xenograft

studies in mice. Dose adjustments may be necessary based on the specific tumor model and observed toxicity.

## Experimental Protocols

### 1. Cell Viability Assay (MTT Assay)

- **Cell Seeding:** Plate cancer cells (e.g., A549, H1975) in a 96-well plate at a density of 5,000 cells/well and allow them to adhere overnight.
- **Compound Treatment:** Prepare serial dilutions of **ZC0109** in culture medium. The final DMSO concentration should not exceed 0.5%. Replace the old medium with the medium containing different concentrations of **ZC0109**. Include a vehicle control (medium with 0.5% DMSO).
- **Incubation:** Incubate the plate for 72 hours at 37°C in a humidified atmosphere with 5% CO<sub>2</sub>.
- **MTT Addition:** Add 20 µL of MTT solution (5 mg/mL in PBS) to each well and incubate for another 4 hours.
- **Formazan Solubilization:** Remove the medium and add 150 µL of DMSO to each well to dissolve the formazan crystals.
- **Absorbance Measurement:** Measure the absorbance at 570 nm using a microplate reader.
- **Data Analysis:** Calculate the percentage of cell viability relative to the vehicle control and determine the IC<sub>50</sub> value by fitting the data to a dose-response curve.

### 2. In Vivo Xenograft Efficacy Study

- **Cell Implantation:** Subcutaneously inject  $5 \times 10^6$  cancer cells (e.g., H1975) in 100 µL of Matrigel into the flank of athymic nude mice.
- **Tumor Growth Monitoring:** Monitor tumor growth every 2-3 days using calipers. Calculate tumor volume using the formula:  $(\text{Length} \times \text{Width}^2) / 2$ .
- **Randomization and Dosing:** When tumors reach an average volume of 100-150 mm<sup>3</sup>, randomize the mice into treatment and control groups (n=8-10 per group).

- Treatment Administration:
  - Vehicle Control Group: Administer the vehicle solution (e.g., 10% DMSO/90% corn oil) daily via intraperitoneal injection.
  - **ZC0109** Treatment Group: Administer **ZC0109** (e.g., 25 mg/kg) dissolved in the vehicle solution daily via intraperitoneal injection.
- Monitoring: Monitor tumor volume, body weight, and general health of the mice every 2-3 days.
- Endpoint: At the end of the study (e.g., 21 days) or when tumors in the control group reach the maximum allowed size, euthanize the mice and excise the tumors for weight measurement and further analysis (e.g., histopathology, biomarker analysis).

## Visualizations

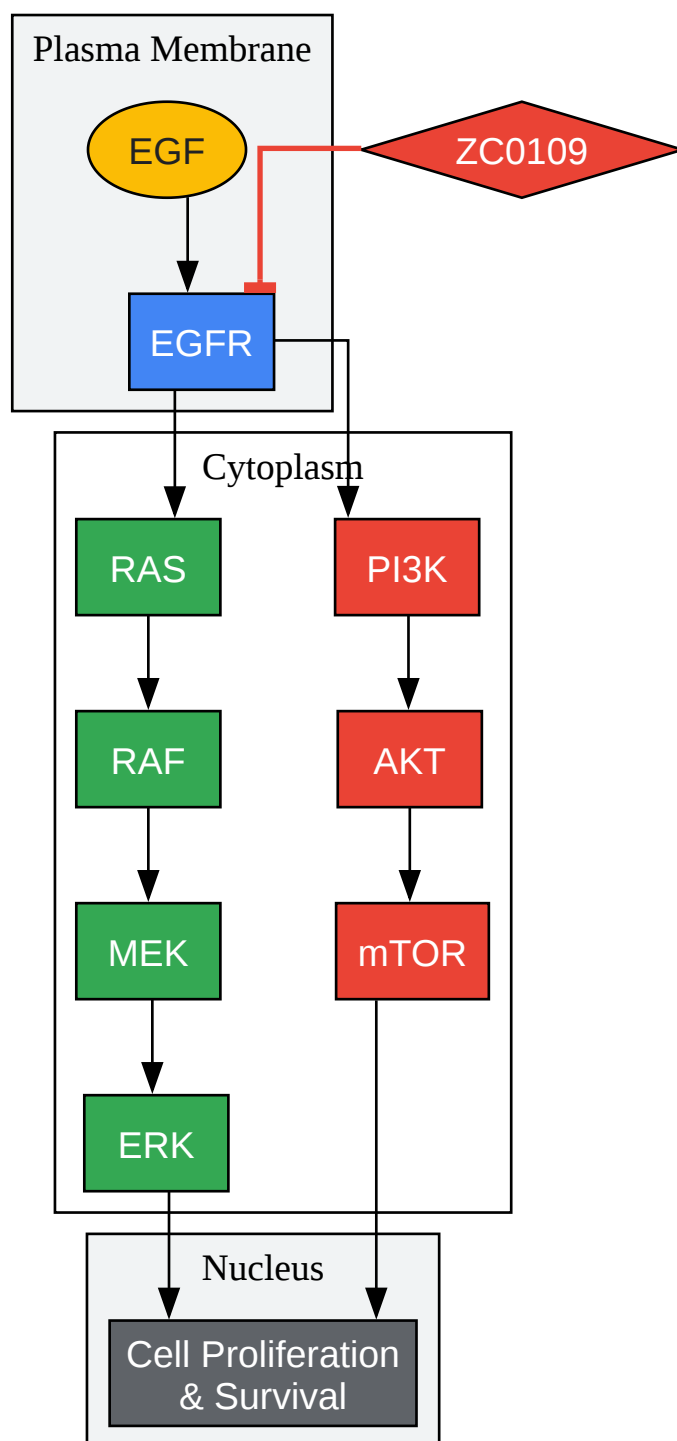

[Click to download full resolution via product page](#)

Caption: **ZC0109** inhibits the EGFR signaling pathway.

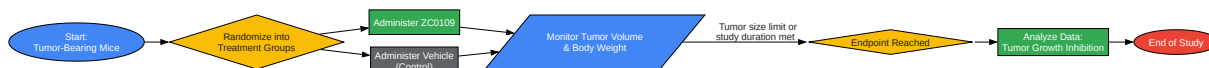

[Click to download full resolution via product page](#)

Caption: Workflow for in vivo efficacy testing of **ZC0109**.

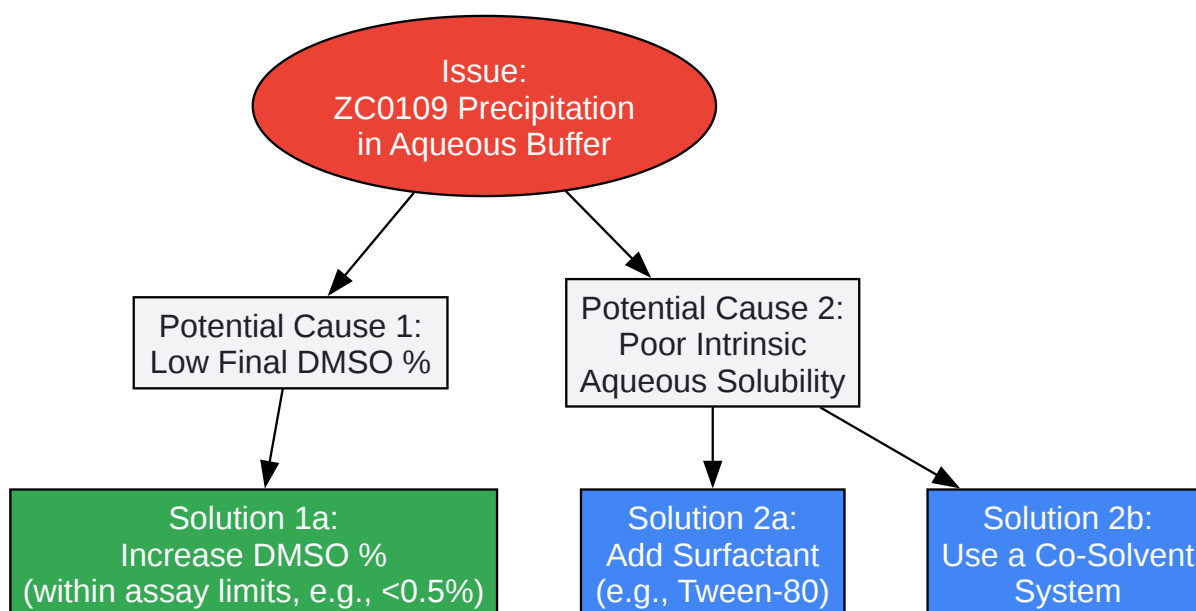

[Click to download full resolution via product page](#)

Caption: Troubleshooting **ZC0109** solubility issues.

- To cite this document: BenchChem. [Technical Support Center: ZC0109 Administration and Efficacy]. BenchChem, [2026]. [Online PDF]. Available at: [\[https://www.benchchem.com/product/b10857258/docs#technical-support-center-zc0109-administration-and-efficacy\]](https://www.benchchem.com/product/b10857258/docs#technical-support-center-zc0109-administration-and-efficacy)

**Disclaimer & Data Validity:**

The information provided in this document is for Research Use Only (RUO) and is strictly not intended for diagnostic or therapeutic procedures. While BenchChem strives to provide accurate protocols, we make no warranties, express or implied, regarding the fitness of this product for every specific experimental setup.

**Technical Support:** The protocols provided are for reference purposes. Unsure if this reagent suits your experiment?

**Need Industrial/Bulk Grade?** [Request Custom Synthesis Quote](#)

## BenchChem

Our mission is to be the trusted global source of essential and advanced chemicals, empowering scientists and researchers to drive progress in science and industry.

### Contact

Address: 3281 E Guasti Rd  
Ontario, CA 91761, United States  
Phone: (601) 213-4426  
Email: [info@benchchem.com](mailto:info@benchchem.com)

[Contact our Ph.D. Support Team for a compatibility check](#)