

Technical Guide: SLC26A3-IN-2 and the Modulation of Intestinal $\text{Cl}^-/\text{HCO}_3^-$ Exchange

Author: BenchChem Technical Support Team. **Date:** April 2026

Compound of Interest

Compound Name: SLC26A3-IN-2

Cat. No.: B10857102

[Get Quote](#)

Audience: Researchers, scientists, and drug development professionals.

Executive Summary

The Solute Carrier Family 26 Member 3 (SLC26A3), also known as Downregulated in Adenoma (DRA), is a crucial anion exchanger located on the apical membrane of intestinal epithelial cells.^{[1][2]} It primarily facilitates the electroneutral exchange of chloride (Cl^-) for bicarbonate (HCO_3^-), a process fundamental to intestinal NaCl and fluid absorption.^{[1][3][4]} Dysregulation of SLC26A3 is implicated in several gastrointestinal disorders. Loss-of-function mutations lead to congenital chloride-losing diarrhea (CLD), while its inhibition presents a promising therapeutic strategy for constipation by reducing colonic fluid absorption.^{[1][2]} This document provides a detailed overview of **SLC26A3-IN-2** and related compounds, such as DRAinh-A250, potent and selective inhibitors of SLC26A3, covering their mechanism of action, pharmacological data, and the experimental protocols used for their discovery and validation.

Introduction to SLC26A3 (DRA)

SLC26A3 is a transmembrane glycoprotein that plays a pivotal role in electrolyte and fluid homeostasis in the lower intestinal tract.^{[4][5]} Its primary function is the one-for-one exchange of luminal Cl^- for intracellular HCO_3^- . This process is functionally coupled with the Na^+/H^+

exchanger 3 (NHE3), which facilitates Na⁺ absorption. The combined action of SLC26A3 and NHE3 results in electroneutral NaCl absorption, creating an osmotic gradient that drives water absorption from the intestinal lumen.[1][4] Given this central role, inhibiting SLC26A3 activity is a targeted approach to increase luminal water content and alleviate constipation.[1][6]

SLC26A3 Inhibitors: Quantitative Pharmacological Data

High-throughput screening of approximately 50,000 synthetic small molecules led to the identification of several classes of SLC26A3 inhibitors.[1][2] Subsequent structure-activity relationship (SAR) studies produced optimized compounds, including the 4,8-dimethylcoumarin derivative DRAinh-A250 and the commercially available **SLC26A3-IN-2**, which is reported to be an orally potent inhibitor.[1][7]

Compound	Chemical Class	IC ₅₀ (SLC26A3 Inhibition)	Selectivity Notes	Reference
DRAinh-A250	4,8-Dimethylcoumarin	100–200 nM	Did not inhibit homologous SLC26A family exchangers or other relevant intestinal transporters.	[1]
SLC26A3-IN-2	Not specified	~360 nM	Potent inhibitor of anion-exchange proteins.	[7]
Niflumic Acid	Fenamate (Non-selective)	Strong inhibition at 350 μM	Non-selective chloride channel blocker, used as a positive control in screening assays.	[1]

Experimental Protocols

The discovery and characterization of SLC26A3 inhibitors involved specific cellular and in vivo assays.

High-Throughput Screening (HTS) for SLC26A3 Inhibitors

This primary assay was designed to identify compounds that block the anion exchange function of SLC26A3 in a high-throughput format.

- Cell Line: Fischer Rat Thyroid (FRT) cells stably co-expressing human SLC26A3 and a genetically encoded halide-sensitive yellow fluorescent protein (YFP-H148Q/I152L).[1][2]
- Assay Principle: The assay measures SLC26A3-mediated Cl^-/I^- exchange. The intracellular YFP fluorescence is quenched by the influx of iodide (I^-). The rate of fluorescence quenching is directly proportional to the SLC26A3 transport activity. Inhibitors of SLC26A3 reduce the rate of I^- entry and thus slow the rate of YFP fluorescence quenching.[1][2]
- Methodology:
 - FRT-YFP-slc26a3 cells are plated in 96-well microplates.
 - Cells are washed with a chloride-containing buffer.
 - Test compounds (e.g., from a 50,000-compound library from ChemDiv) are added to the wells at a concentration of 25 μM . [1]
 - The plate is transferred to a fluorescence plate reader. Baseline fluorescence is recorded.
 - An iodide-containing solution is injected into the wells to initiate the Cl^-/I^- exchange.
 - YFP fluorescence is monitored over time. The initial rate of fluorescence decrease is calculated.
 - Data is normalized to controls: vehicle (DMSO) for maximal activity and a non-selective inhibitor like niflumic acid (350 μM) for maximal inhibition. [1]

- The Z-factor, a measure of assay quality, was reported to be ~0.7.[1]

In Vivo Efficacy Model: Loperamide-Induced Constipation

This model was used to assess the anti-constipation effect of the identified SLC26A3 inhibitors in mice.

- Animal Model: Wild-type (C57BL/6) or cystic fibrosis mice.[1]
- Induction of Constipation: Mice are treated with loperamide, an opioid-receptor agonist that inhibits intestinal motility and fluid secretion, leading to constipation.
- Methodology:
 - Mice are administered the test compound (e.g., DRAinh-A250, 5 mg/kg) or vehicle control orally.
 - After a set period, loperamide is administered subcutaneously to induce constipation.
 - Mice are housed in individual cages with free access to water but not food.
 - Stool is collected over a period of 3 hours.
 - The following parameters are measured: total stool weight, number of fecal pellets, and stool water content (calculated as $[(\text{wet weight} - \text{dry weight}) / \text{wet weight}] \times 100$).[1]
 - A significant increase in stool weight and water content in the compound-treated group compared to the vehicle group indicates efficacy.

Visualizations: Pathways and Workflows

Intestinal Electroneutral NaCl Absorption Pathway

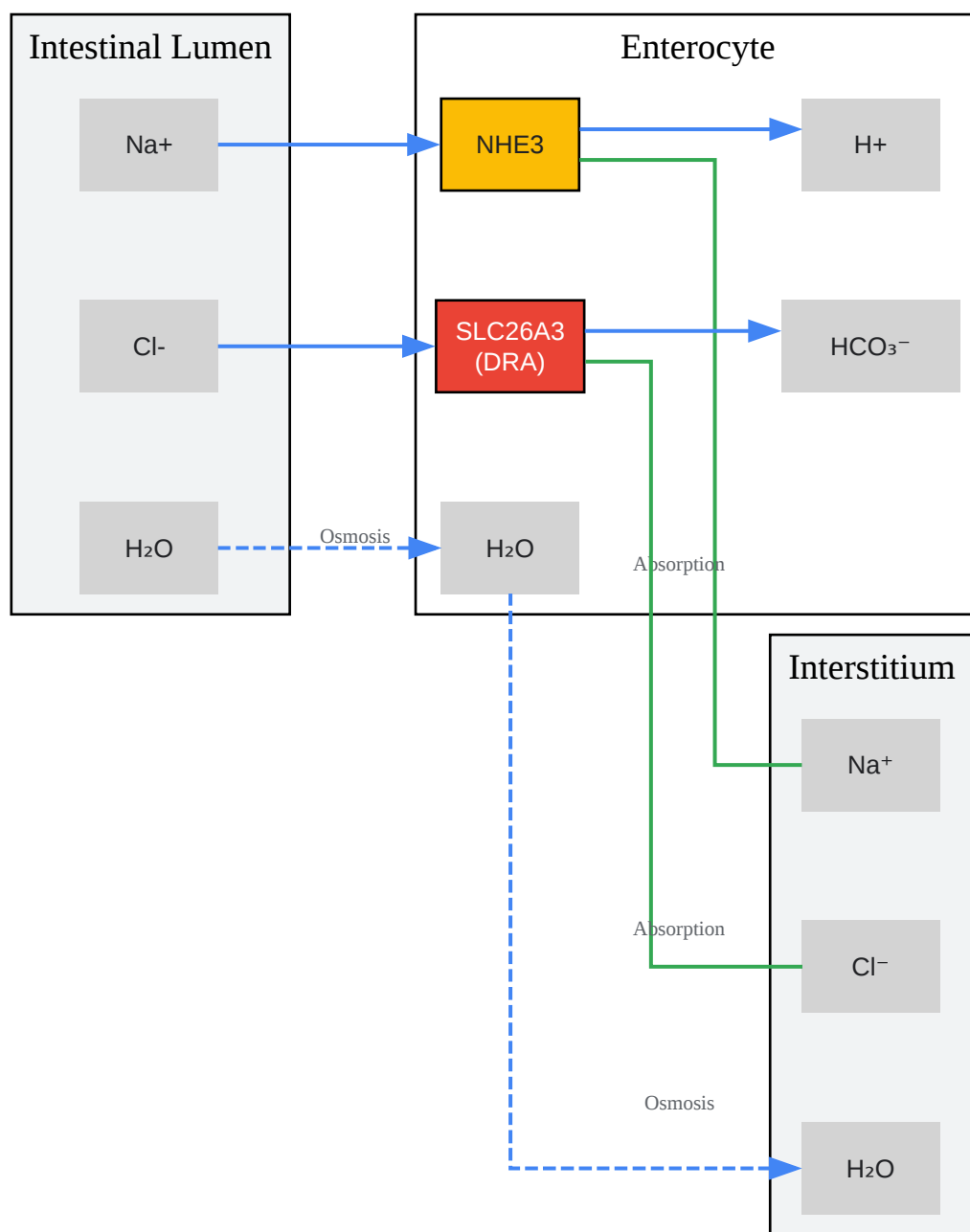

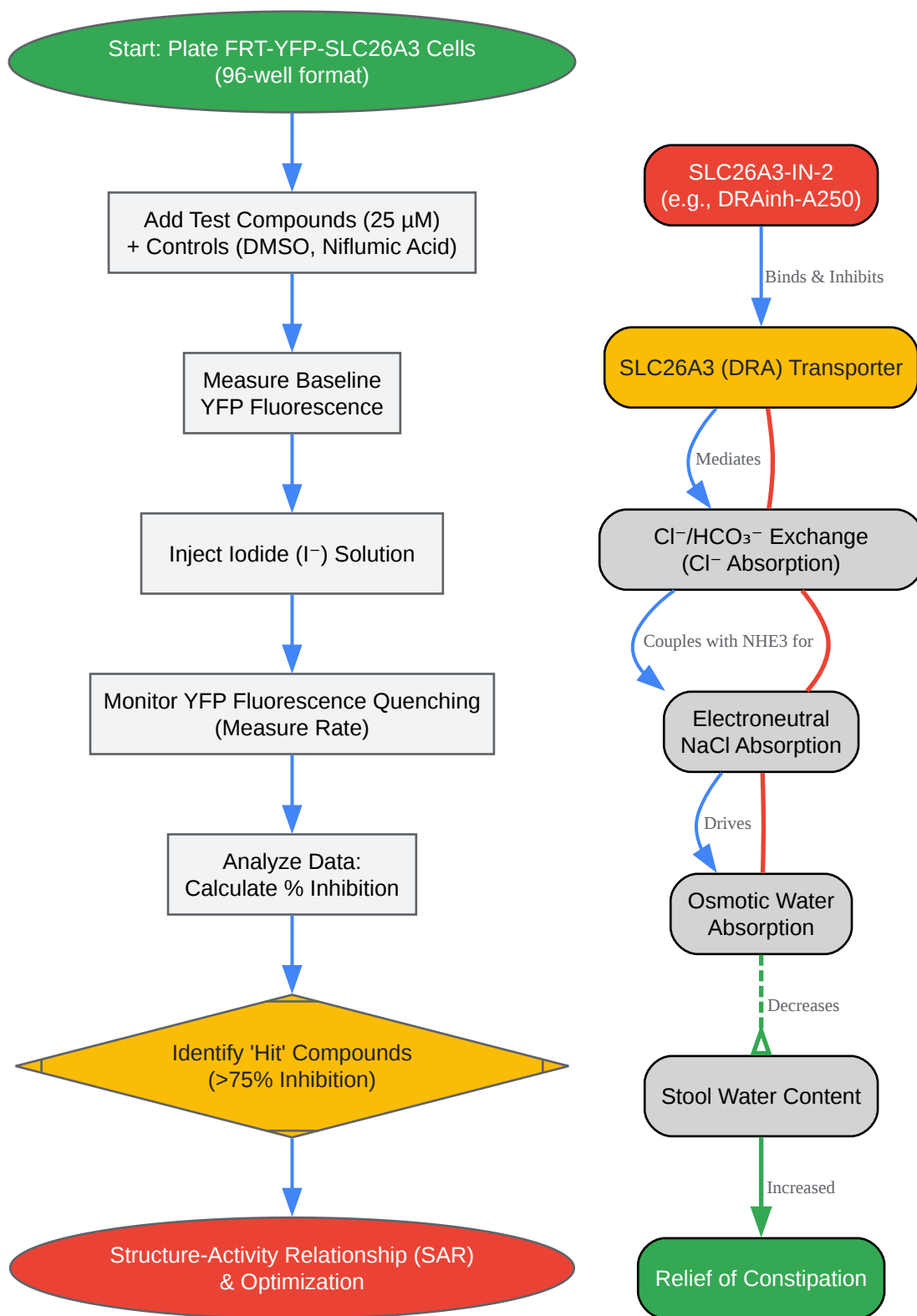

[Click to download full resolution via product page](#)

Need Custom Synthesis?

BenchChem offers custom synthesis for rare earth carbides and specific isotopic labeling.

Email: info@benchchem.com or [Request Quote Online](#).

References

- 1. SLC26A3 inhibitor identified in small molecule screen blocks colonic fluid absorption and reduces constipation - PMC [[pmc.ncbi.nlm.nih.gov](https://pubmed.ncbi.nlm.nih.gov/)]
- 2. JCI Insight - SLC26A3 inhibitor identified in small molecule screen blocks colonic fluid absorption and reduces constipation [insight.jci.org]
- 3. journals.physiology.org [journals.physiology.org]
- 4. SLC26A3 (DRA, the Congenital Chloride Diarrhea Gene): A Novel Therapeutic Target for Diarrheal Diseases - PMC [[pmc.ncbi.nlm.nih.gov](https://pubmed.ncbi.nlm.nih.gov/)]
- 5. SLC26A3 solute carrier family 26 member 3 [Homo sapiens (human)] - Gene - NCBI [[ncbi.nlm.nih.gov](https://pubmed.ncbi.nlm.nih.gov/)]
- 6. What are SLC26A3 inhibitors and how do they work? [synapse.patsnap.com]
- 7. apexbt.com [apexbt.com]
- To cite this document: BenchChem. [Technical Guide: SLC26A3-IN-2 and the Modulation of Intestinal Cl⁻/HCO₃⁻ Exchange]. BenchChem, [2026]. [Online PDF]. Available at: [<https://www.benchchem.com/product/b10857102/docs#technical-guide-slc26a3-in-2-and-the-modulation-of-intestinal-cl-hco-exchange>]

Disclaimer & Data Validity:

The information provided in this document is for Research Use Only (RUO) and is strictly not intended for diagnostic or therapeutic procedures. While BenchChem strives to provide accurate protocols, we make no warranties, express or implied, regarding the fitness of this product for every specific experimental setup.

Technical Support: The protocols provided are for reference purposes. Unsure if this reagent suits your experiment?

Need Industrial/Bulk Grade? [Request Custom Synthesis Quote](#)

BenchChem

Our mission is to be the trusted global source of essential and advanced chemicals, empowering scientists and researchers to drive progress in science and industry.

Contact

Address: 3281 E Guasti Rd

Ontario, CA 91761, United States

Phone: (601) 213-4426

Email: info@benchchem.com

[Contact our Ph.D. Support Team for a compatibility check](#)