

In Vivo Efficacy of IL-17 Modulators: A Comparative Guide

Author: BenchChem Technical Support Team. **Date:** April 2026

Compound of Interest

Compound Name: *IL-17 modulator 3*

Cat. No.: *B10857777*

[Get Quote](#)

For Researchers, Scientists, and Drug Development Professionals

This guide provides an objective comparison of the in vivo efficacy of three key interleukin-17 (IL-17) modulators: secukinumab, ixekizumab, and brodalumab. The information is curated from both preclinical animal studies and clinical trials to support research and development in autoimmune and inflammatory diseases. While direct head-to-head preclinical data is limited, this guide synthesizes available evidence to draw meaningful comparisons.

IL-17 Signaling Pathway

The interleukin-17 family of cytokines are key drivers of inflammation in numerous autoimmune diseases. IL-17A and IL-17F, produced predominantly by T helper 17 (Th17) cells, signal through a heterodimeric receptor complex composed of IL-17RA and IL-17RC. This interaction recruits the adaptor protein Act1, which in turn activates downstream signaling cascades, including NF- κ B and MAPK pathways. The ultimate result is the transcription of pro-inflammatory genes that lead to tissue inflammation and damage. Brodalumab targets the IL-17RA subunit, thereby blocking the signaling of multiple IL-17 family members, whereas secukinumab and ixekizumab specifically neutralize the IL-17A cytokine.

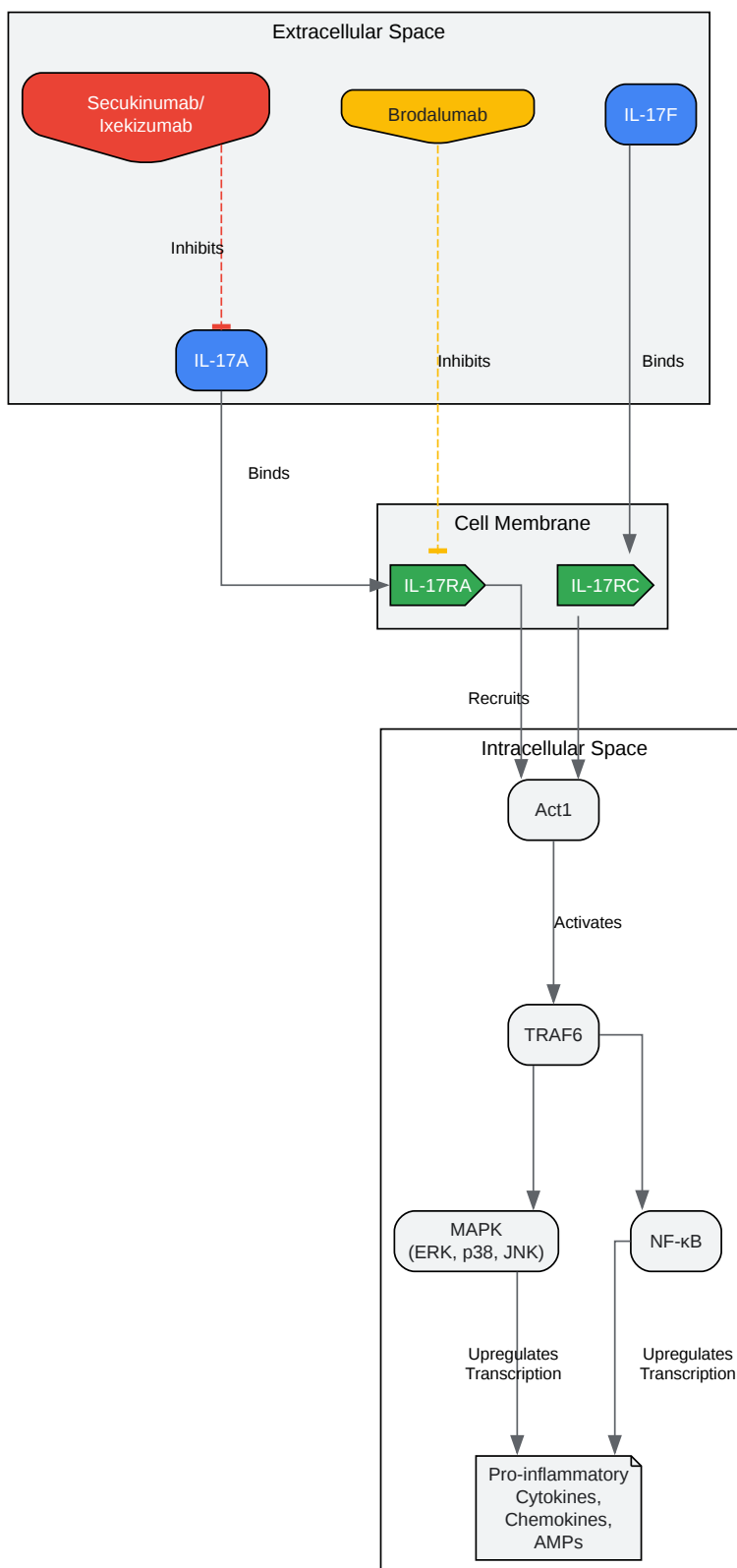

[Click to download full resolution via product page](#)

Figure 1. Simplified IL-17 Signaling Pathway and Points of Inhibition.

Comparative Efficacy Data

The following tables summarize the in vivo efficacy of secukinumab, ixekizumab, and brodalumab from preclinical and clinical studies.

Preclinical Efficacy in Animal Models

Direct head-to-head preclinical studies of these specific commercial antibodies are not extensively published. However, studies using anti-IL-17A antibodies in mouse models of psoriasis and arthritis demonstrate the principle of efficacy.

Model	IL-17 Modulator Type	Key Efficacy Endpoints	Outcome
Imiquimod-Induced Psoriasis (Mouse)	Anti-IL-17A Antibody	Reduction in Psoriasis Area and Severity Index (PASI) score, decreased skin thickness, reduced inflammatory cell infiltration.	Significant reduction in disease severity compared to control. Antibody treatment can lead to a ~50% inhibition of the PASI score.[1]
Collagen-Induced Arthritis (Mouse)	Anti-IL-17A Antibody	Reduced clinical arthritis score, decreased joint inflammation and bone erosion, lower serum levels of IL-6 and G-CSF.	Significant amelioration of arthritis severity. Neutralization of IL-17A is more effective than targeting IL-17F. [2]
Collagen-Induced Arthritis (Mouse)	Anti-IL-17A + Anti-TNF α Antibodies	Clinical arthritis score.	Combination therapy was more effective in improving disease scores than monotherapy.[3][4]

Clinical Efficacy in Plaque Psoriasis

Clinical trials provide a wealth of comparative data for these IL-17 modulators in human patients. The Psoriasis Area and Severity Index (PASI) is a widely used measure, with PASI 75, 90, and 100 indicating a 75%, 90%, and 100% reduction in PASI score from baseline, respectively.

IL-17 Modulator	Target	PASI 75 Response (Week 12)	PASI 90 Response (Week 12)	PASI 100 Response (Week 12)
Secukinumab	IL-17A	~64.4% - 83.6%	~49.2% - 77.9%	~41.4% - 74.6%
Ixekizumab	IL-17A	~75.9% - 82.1%	~62.1% - 72.4%	~41.4% - 69.9%
Brodalumab	IL-17RA	~83.3% - 86.3%	Not consistently reported at week 12	~37% - 44%

Note: Efficacy rates are approximate and can vary based on the specific clinical trial and patient population.

Experimental Protocols

Imiquimod-Induced Psoriasis Model

This is a widely used acute model that recapitulates many features of human psoriasis.

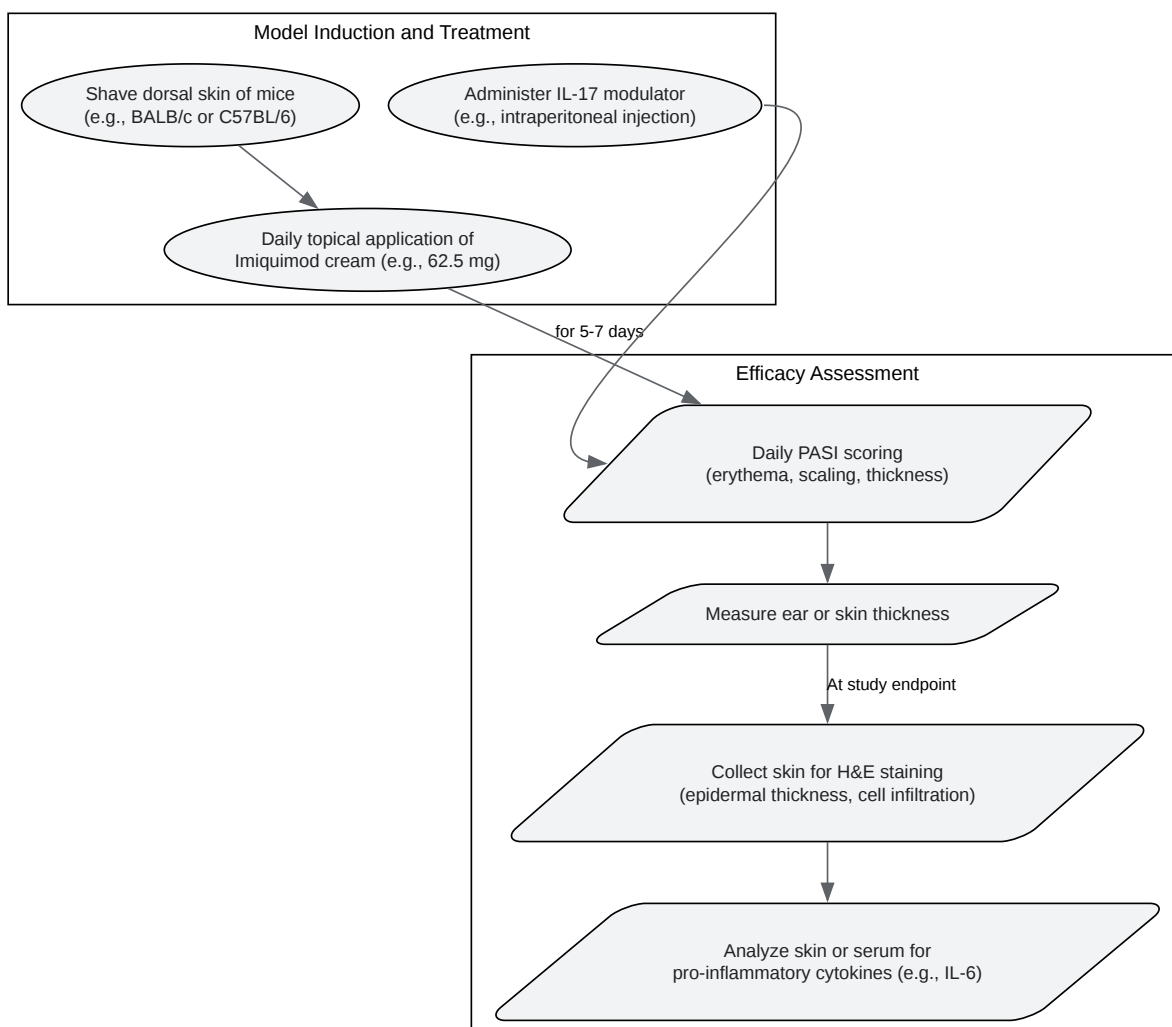

[Click to download full resolution via product page](#)

Figure 2. Experimental Workflow for the Imiquimod-Induced Psoriasis Model.

Key Methodological Points:

- **Animals:** Typically 8-12 week old female BALB/c or C57BL/6 mice are used.
- **Imiquimod Application:** A daily dose of 5% imiquimod cream is applied to the shaved back and sometimes the ear for 5-7 consecutive days.[1]
- **Treatment:** IL-17 modulators or vehicle controls are typically administered systemically (e.g., via intraperitoneal or subcutaneous injection) starting from the day of or the day before the first imiquimod application.
- **Efficacy Readouts:**
 - **Clinical Scoring:** The Psoriasis Area and Severity Index (PASI) is adapted for mice, scoring erythema, scaling, and skin thickness.
 - **Histopathology:** Skin biopsies are taken at the end of the study and stained with Hematoxylin and Eosin (H&E) to assess epidermal thickening (acanthosis) and inflammatory cell infiltration.
 - **Biomarker Analysis:** Skin or serum can be analyzed for levels of pro-inflammatory cytokines such as IL-6, IL-23, and IL-17 itself using methods like ELISA or qPCR.

Collagen-Induced Arthritis (CIA) Model

The CIA model is a well-established model for studying inflammatory arthritis, sharing many pathological features with human rheumatoid arthritis.

Key Methodological Points:

- **Animals:** DBA/1 mice are highly susceptible and commonly used.
- **Induction:** An initial immunization of type II collagen emulsified in Complete Freund's Adjuvant (CFA) is administered intradermally at the base of the tail. A booster immunization with type II collagen in Incomplete Freund's Adjuvant (IFA) is typically given 21 days later.
- **Treatment:** Administration of IL-17 modulators usually begins at the time of the booster immunization or upon the first signs of arthritis.

- Efficacy Readouts:
 - Clinical Scoring: Arthritis severity is scored visually based on paw swelling and redness.
 - Histopathology: Joint tissues are collected for H&E staining to assess inflammation, cartilage damage, and bone erosion.
 - Biomarker Analysis: Serum levels of anti-collagen antibodies and pro-inflammatory cytokines like IL-6 can be measured.

Summary and Conclusion

The available data, predominantly from clinical trials, indicates that all three IL-17 modulators—secukinumab, ixekizumab, and brodalumab—are highly effective in treating IL-17-mediated diseases like psoriasis. Secukinumab and ixekizumab, which both target IL-17A, show comparable and high levels of efficacy. Brodalumab, by targeting the IL-17RA receptor, offers a broader blockade of the IL-17 pathway and also demonstrates robust efficacy.

Preclinical animal models, such as the imiquimod-induced psoriasis and collagen-induced arthritis models, provide a valuable platform for evaluating the in vivo efficacy of novel IL-17 modulators. While direct comparative preclinical data for the approved biologics is scarce in the public domain, the consistent and strong efficacy of anti-IL-17A antibodies in these models validates the therapeutic approach. For researchers and drug developers, the choice of model and specific endpoints is critical for elucidating the in vivo mechanisms and potential of new therapeutic candidates targeting the IL-17 pathway.

Need Custom Synthesis?

BenchChem offers custom synthesis for rare earth carbides and specific isotopic labeling.

Email: info@benchchem.com or [Request Quote Online](#).

References

- [1. Application of imiquimod-induced murine psoriasis model in evaluating interleukin-17A antagonist - PMC \[pmc.ncbi.nlm.nih.gov\]](#)

- [2. Interleukin \(IL\)-17A, F and AF in inflammation: a study in collagen-induced arthritis and rheumatoid arthritis - PMC \[pmc.ncbi.nlm.nih.gov\]](#)
- [3. Combined Blockade of TNF- \$\alpha\$ and IL-17A Alleviates Progression of Collagen-Induced Arthritis without Causing Serious Infections in Mice - PubMed \[pubmed.ncbi.nlm.nih.gov\]](#)
- [4. Combined Blockade of TNF \$\alpha\$ and IL-17A Ameliorates Progression of Collagen-Induced Arthritis without Causing Serious Infections in Mice - PMC \[pmc.ncbi.nlm.nih.gov\]](#)
- To cite this document: BenchChem. [In Vivo Efficacy of IL-17 Modulators: A Comparative Guide]. BenchChem, [2026]. [Online PDF]. Available at: [\[https://www.benchchem.com/product/b10857777/docs#in-vivo-efficacy-of-il-17-modulators-a-comparative-guide\]](https://www.benchchem.com/product/b10857777/docs#in-vivo-efficacy-of-il-17-modulators-a-comparative-guide)

Disclaimer & Data Validity:

The information provided in this document is for Research Use Only (RUO) and is strictly not intended for diagnostic or therapeutic procedures. While BenchChem strives to provide accurate protocols, we make no warranties, express or implied, regarding the fitness of this product for every specific experimental setup.

Technical Support: The protocols provided are for reference purposes. Unsure if this reagent suits your experiment?

Need Industrial/Bulk Grade? [Request Custom Synthesis Quote](#)

BenchChem

Our mission is to be the trusted global source of essential and advanced chemicals, empowering scientists and researchers to drive progress in science and industry.

Contact

Address: 3281 E Guasti Rd
Ontario, CA 91761, United States
Phone: (601) 213-4426
Email: info@benchchem.com

Contact our Ph.D. Support Team for a compatibility check