

# Common issues with JB061 stability in solution

**Author:** BenchChem Technical Support Team. **Date:** April 2026

## Compound of Interest

Compound Name: JB061  
Cat. No.: B10857308

[Get Quote](#)

## Technical Support Center: JB061

This technical support center provides researchers, scientists, and drug development professionals with comprehensive guidance on the use of **JB061**, a potent and selective myosin II inhibitor. While **JB061** is noted for its generally good solubility and chemical stability, this guide addresses common issues that may be encountered in solution to ensure experimental success and reproducibility.

## Troubleshooting Guide

This section addresses specific issues users might encounter during their experiments in a question-and-answer format.

Issue 1: My **JB061** solution is cloudy or has visible precipitate after dilution in my aqueous experimental buffer.

- **Possible Cause:** This is likely due to the lower solubility of **JB061** in aqueous solutions compared to organic solvents like DMSO. When a concentrated DMSO stock is diluted into a buffer, the **JB061** may crash out if its solubility limit is exceeded.
- **Troubleshooting Steps:**

- **Verify Stock Concentration:** Ensure your DMSO stock solution is not over-concentrated. A recommended starting concentration is 10-20 mM.
- **Optimize Dilution Method:** Add the DMSO stock solution to your aqueous buffer dropwise while vortexing or stirring vigorously. This helps to disperse the compound quickly and avoid localized high concentrations that lead to precipitation.
- **Reduce Final Concentration:** The effective concentration of **JB061** in many cell-based assays is in the low micromolar range. Try lowering the final concentration in your experiment.
- **Consider a Co-solvent:** If your experimental design allows, a small percentage of a co-solvent like Pluronic F-127 or a lower percentage of DMSO in the final solution might help maintain solubility. Always run a vehicle control to account for any effects of the co-solvent.

Issue 2: I'm observing a decrease in the inhibitory activity of my **JB061** working solution over a few hours at room temperature.

- **Possible Cause:** **JB061** is a 4-hydroxycoumarin imine.<sup>[1]</sup> Like other imines, it can be susceptible to hydrolysis, especially in aqueous solutions, which would lead to degradation and loss of activity.<sup>[2][3][4][5][6]</sup> The rate of this degradation can be influenced by pH and temperature.
- **Troubleshooting Steps:**
  - **Prepare Fresh Solutions:** The most reliable practice is to prepare fresh aqueous working solutions of **JB061** from a frozen DMSO stock immediately before each experiment.
  - **Control Temperature:** Keep working solutions on ice and minimize the time they are kept at room temperature or in a 37°C incubator.
  - **Check Buffer pH:** The stability of imines can be pH-dependent.<sup>[6]</sup> While specific data for **JB061** is not publicly available, it is good practice to ensure your buffer pH is stable and controlled throughout the experiment. Consider performing a pilot study to assess stability in your specific buffer system if you suspect pH-related degradation.

Issue 3: My experimental results with **JB061** are inconsistent between experiments.

- Possible Cause: Inconsistent results often stem from variations in the preparation, storage, or handling of the inhibitor solution. The age of the working solution, number of freeze-thaw cycles of the stock, and exposure to light can all contribute.
- Troubleshooting Steps:
  - Standardize Solution Handling: Follow a strict, standardized protocol for preparing and using **JB061** for every experiment.
  - Aliquot Stock Solutions: Aliquot your high-concentration DMSO stock into single-use volumes and store them at -20°C or -80°C. This prevents repeated freeze-thaw cycles which can degrade the compound.
  - Protect from Light: While not reported as a major issue for **JB061**, it is general best practice for complex organic molecules to protect solutions from direct, prolonged exposure to light. Use amber vials or wrap tubes in foil.

## Frequently Asked Questions (FAQs)

Q1: What is the recommended solvent for preparing **JB061** stock solutions?

A1: High-quality, anhydrous DMSO (Dimethyl sulfoxide) is the recommended solvent for preparing concentrated stock solutions of **JB061**.<sup>[7]</sup>

Q2: How should I store my **JB061** stock and working solutions?

A2: DMSO stock solutions should be aliquoted into single-use vials and stored tightly sealed at -20°C or -80°C, protected from light. Aqueous working solutions are not recommended for long-term storage and should be prepared fresh for each experiment.

Q3: What is the primary potential degradation pathway for **JB061**?

A3: As an imine-containing compound, the most probable chemical degradation pathway in aqueous solution is hydrolysis.<sup>[2][3][4]</sup> This reaction would break the C=N imine bond, converting the molecule back to its constituent amine and carbonyl compounds, rendering it inactive as a myosin II inhibitor.

Q4: How does **JB061** inhibit Myosin II?

A4: **JB061** is an inhibitor of the Myosin II ATPase activity.[1] It is believed to bind to the same site as other inhibitors like blebbistatin, which traps the myosin in a state with low affinity for actin, thus preventing the force-producing power stroke.[1][8]

## Data Presentation

Disclaimer: The following tables contain illustrative data based on the general properties of 4-hydroxycoumarin imines and are intended to serve as a guideline. Actual experimental values should be determined empirically.

Table 1: Illustrative Solubility of **JB061**

Solvent	Estimated Solubility	Notes
DMSO	> 50 mM	<b>Recommended for stock solutions.</b>
Ethanol	~ 5-10 mM	Can be used, but DMSO is preferred.
PBS (pH 7.4)	< 20 µM	Solubility is limited in aqueous buffers.

| Cell Culture Media + 10% FBS | < 25 µM | Protein binding may slightly increase apparent solubility. |

Table 2: Illustrative Stability of **JB061** in Aqueous Buffer (pH 7.4)

Temperature	Estimated Half-life (t <sub>1/2</sub> )	Recommendation
37°C	2 - 4 hours	<b>Prepare fresh and use immediately for cell-based assays.</b>
20-25°C (Room Temp)	6 - 8 hours	Minimize time at room temperature.
4°C	> 24 hours	Keep on ice during experimental setup.

| -20°C | Days to Weeks | Not recommended for aqueous solutions due to freezing. |

## Experimental Protocols

### Protocol 1: Preparation of **JB061** Stock and Working Solutions

- **Stock Solution Preparation (10 mM in DMSO):** a. Weigh out the required amount of **JB061** powder in a sterile microcentrifuge tube. b. Add the appropriate volume of anhydrous, high-purity DMSO to achieve a 10 mM concentration. c. Vortex thoroughly for 2-3 minutes until the solid is completely dissolved. d. Aliquot the stock solution into smaller, single-use volumes in amber or foil-wrapped tubes. e. Store the aliquots at -20°C or -80°C.
- **Working Solution Preparation (e.g., 10 µM in Cell Culture Medium):** a. Thaw a single aliquot of the 10 mM DMSO stock solution at room temperature. b. Pre-warm the required volume of cell culture medium or experimental buffer to the desired temperature (e.g., 37°C). c. Perform a serial dilution. For example, dilute the 10 mM stock 1:100 in buffer to get a 100 µM intermediate solution. d. Add the required volume of the 100 µM intermediate solution to the final volume of pre-warmed medium while gently vortexing to achieve the final 10 µM concentration. The final DMSO concentration should be kept low (typically ≤ 0.1%) to avoid solvent effects. e. Use the working solution immediately.

## Visualizations

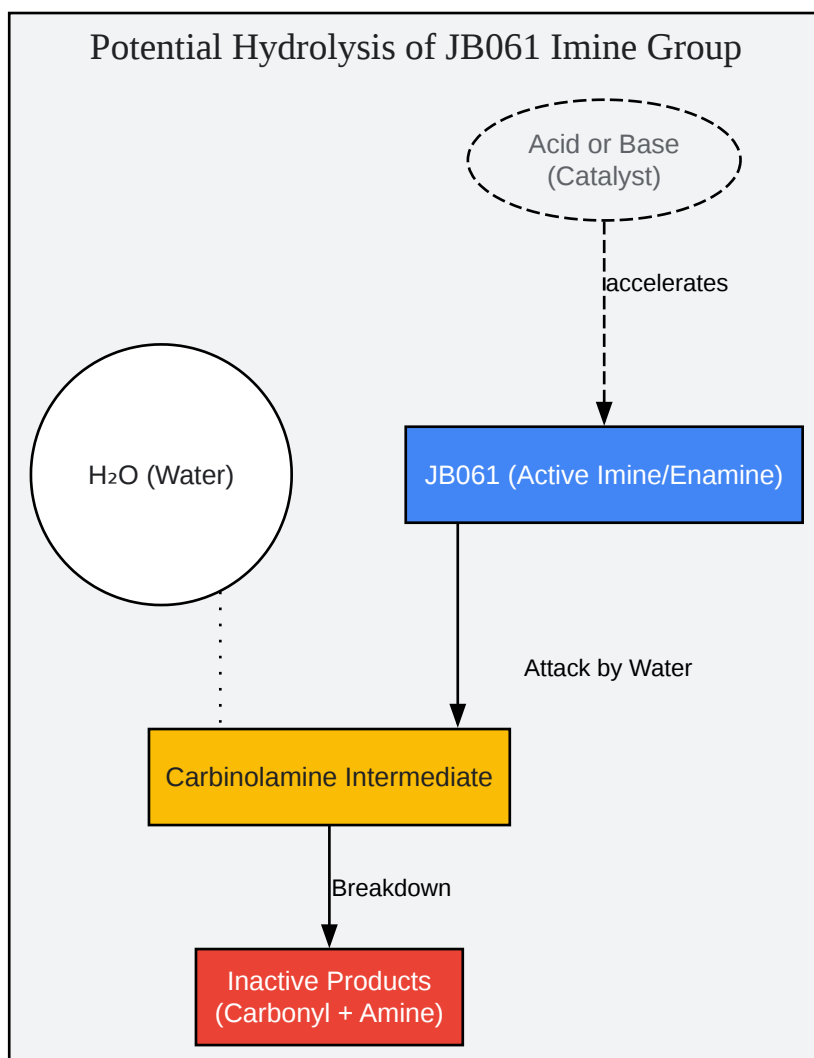

[Click to download full resolution via product page](#)

Potential hydrolysis pathway for the **JB061** imine group.

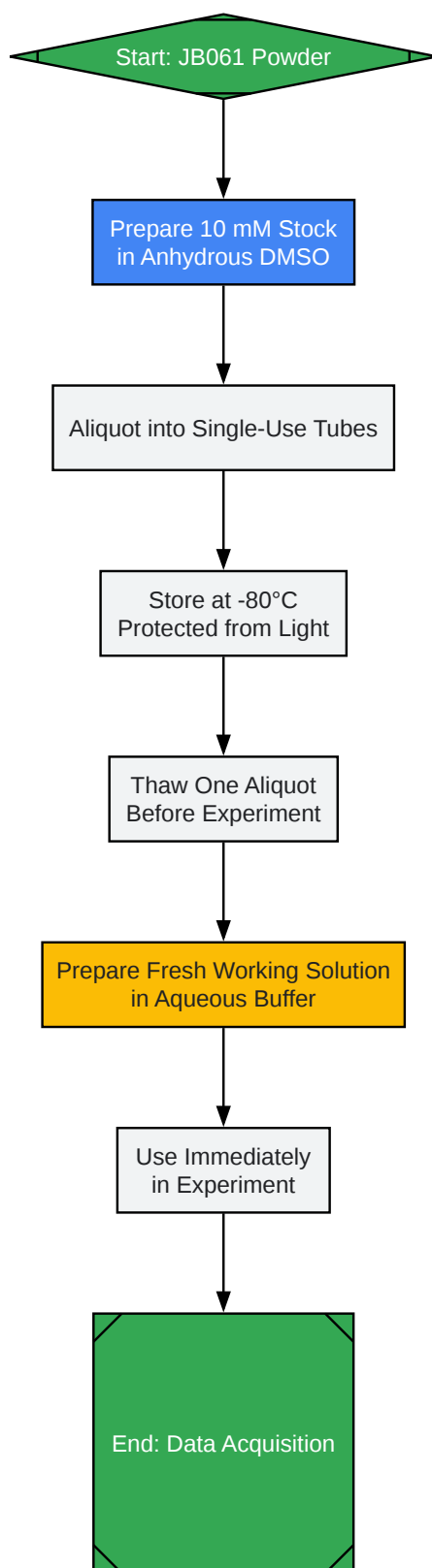

[Click to download full resolution via product page](#)

Recommended workflow for preparing and using **JB061** solutions.

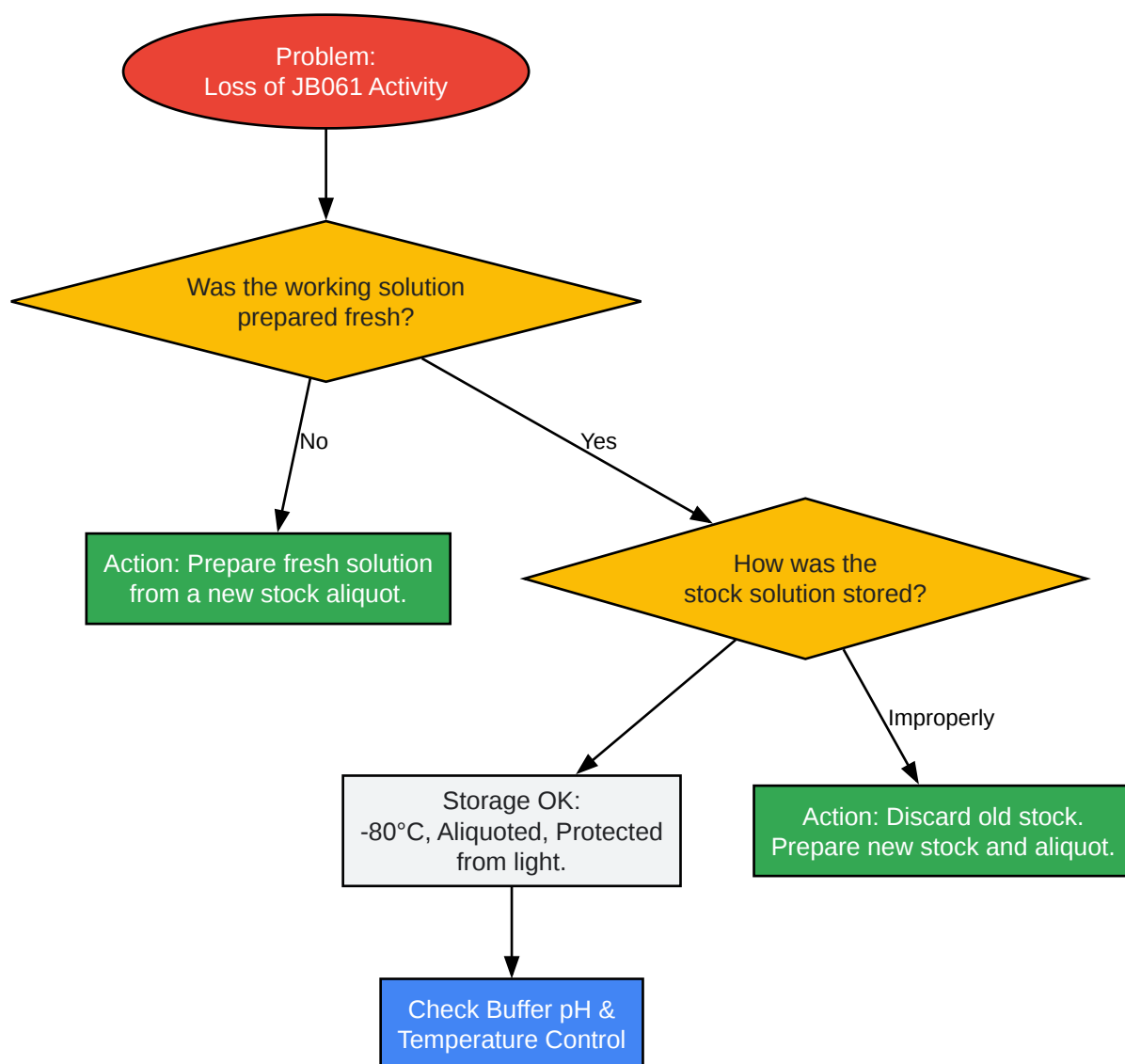

[Click to download full resolution via product page](#)

Troubleshooting logic for **JB061** stability issues.

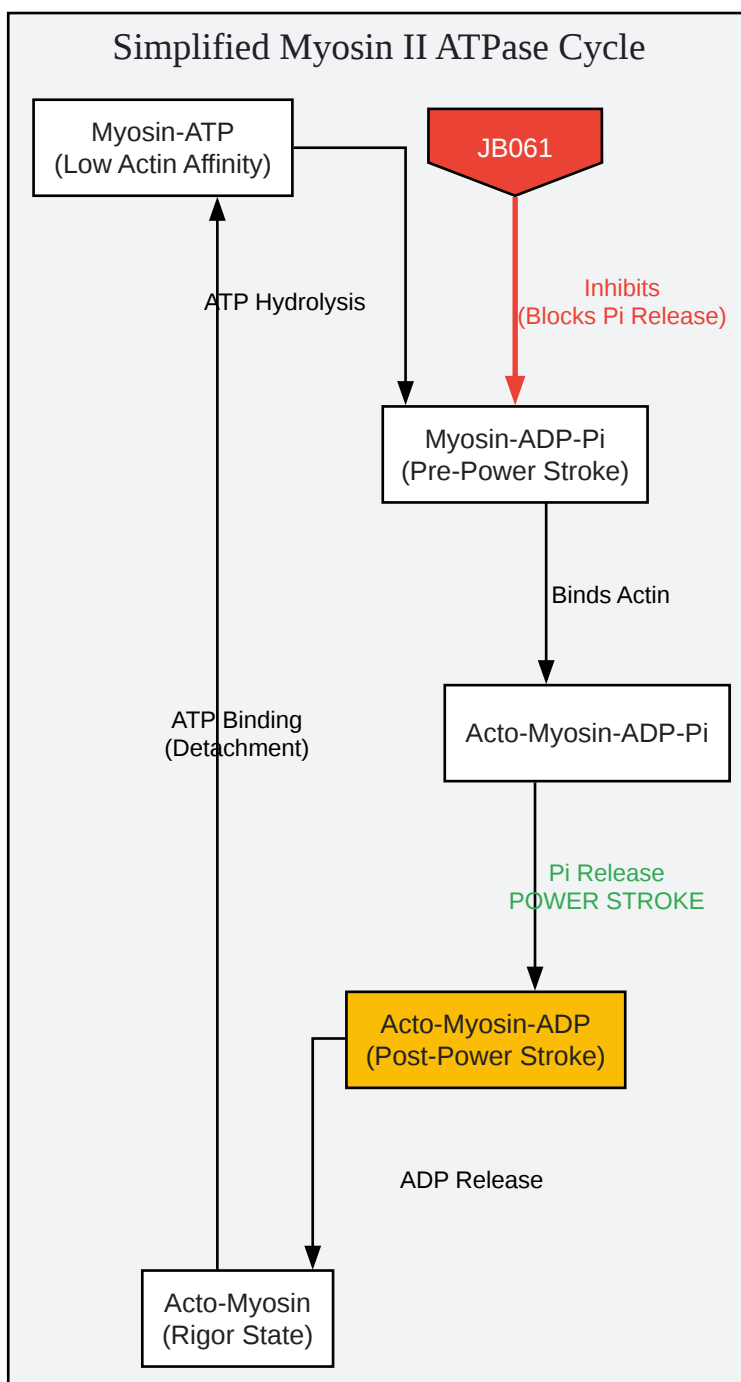

[Click to download full resolution via product page](#)

Simplified Myosin II signaling pathway inhibited by **JB061**.

**Need Custom Synthesis?**

BenchChem offers custom synthesis for rare earth carbides and specific isotopic labeling.

Email: [info@benchchem.com](mailto:info@benchchem.com) or [Request Quote Online](#).

## References

- [1. Synthesis and Evaluation of 4-Hydroxycoumarin Imines as Inhibitors of Class II Myosins - PMC \[pmc.ncbi.nlm.nih.gov\]](#)
- [2. Imine and Enamine Hydrolysis Mechanism - Chemistry Steps \[chemistrysteps.com\]](#)
- [3. byjus.com \[byjus.com\]](#)
- [4. news-medical.net \[news-medical.net\]](#)
- [5. masterorganicchemistry.com \[masterorganicchemistry.com\]](#)
- [6. masterorganicchemistry.com \[masterorganicchemistry.com\]](#)
- [7. benchchem.com \[benchchem.com\]](#)
- [8. biorxiv.org \[biorxiv.org\]](#)
- To cite this document: BenchChem. [Common issues with JB061 stability in solution]. BenchChem, [2026]. [Online PDF]. Available at: [\[https://www.benchchem.com/product/b10857308/docs#common-issues-with-jb061-stability-in-solution\]](https://www.benchchem.com/product/b10857308/docs#common-issues-with-jb061-stability-in-solution)

---

**Disclaimer & Data Validity:**

The information provided in this document is for Research Use Only (RUO) and is strictly not intended for diagnostic or therapeutic procedures. While BenchChem strives to provide accurate protocols, we make no warranties, express or implied, regarding the fitness of this product for every specific experimental setup.

**Technical Support:** The protocols provided are for reference purposes. Unsure if this reagent suits your experiment?

**Need Industrial/Bulk Grade?** [Request Custom Synthesis Quote](#)

# BenchChem

Our mission is to be the trusted global source of essential and advanced chemicals, empowering scientists and researchers to drive progress in science and industry.

## Contact

Address: 3281 E Guasti Rd

Ontario, CA 91761, United States

Phone: (601) 213-4426

Email: [info@benchchem.com](mailto:info@benchchem.com)

[Contact our Ph.D. Support Team for a compatibility check](#)