

Application Notes and Protocols for SLC26A3-IN-2 Studies

Author: BenchChem Technical Support Team. **Date:** April 2026

Compound of Interest

Compound Name: SLC26A3-IN-2

Cat. No.: B10857102

[Get Quote](#)

For Researchers, Scientists, and Drug Development Professionals

These application notes provide detailed protocols for the in vitro and ex vivo characterization of **SLC26A3-IN-2**, a potent and orally active inhibitor of the Solute Carrier Family 26 Member 3 (SLC26A3) anion exchanger, also known as Downregulated in Adenoma (DRA).

Introduction

SLC26A3 is a crucial anion exchanger located on the apical membrane of intestinal epithelial cells, mediating the exchange of chloride (Cl^-) and bicarbonate (HCO_3^-). This process is fundamental for electroneutral NaCl absorption and subsequent water absorption in the intestines.[1][2] Dysregulation of SLC26A3 function is associated with gastrointestinal disorders such as congenital chloride diarrhea and has been implicated in inflammatory bowel disease. [1][2] **SLC26A3-IN-2** has been identified as a specific inhibitor of SLC26A3, offering a valuable tool for studying its physiological roles and as a potential therapeutic agent for conditions like constipation.[1][3][4]

Data Presentation

Table 1: In Vitro Efficacy of **SLC26A3-IN-2**

Compound	Target	Assay	IC ₅₀ (nM)	Inhibition Rate
SLC26A3-IN-2	SLC26A3	Anion Exchange	360	92% at 10 µM

Data sourced from MedchemExpress.[3]

Table 2: In Vivo Efficacy of **SLC26A3-IN-2** in a Loperamide-Induced Constipation Mouse Model

Treatment	Dosage (mg/kg, p.o.)	Effect on Stool Weight	Effect on Pellet Number
SLC26A3-IN-2	10	Significantly Increased	Significantly Increased

Data sourced from MedchemExpress.[3]

Mandatory Visualizations

Signaling and Transport Pathway

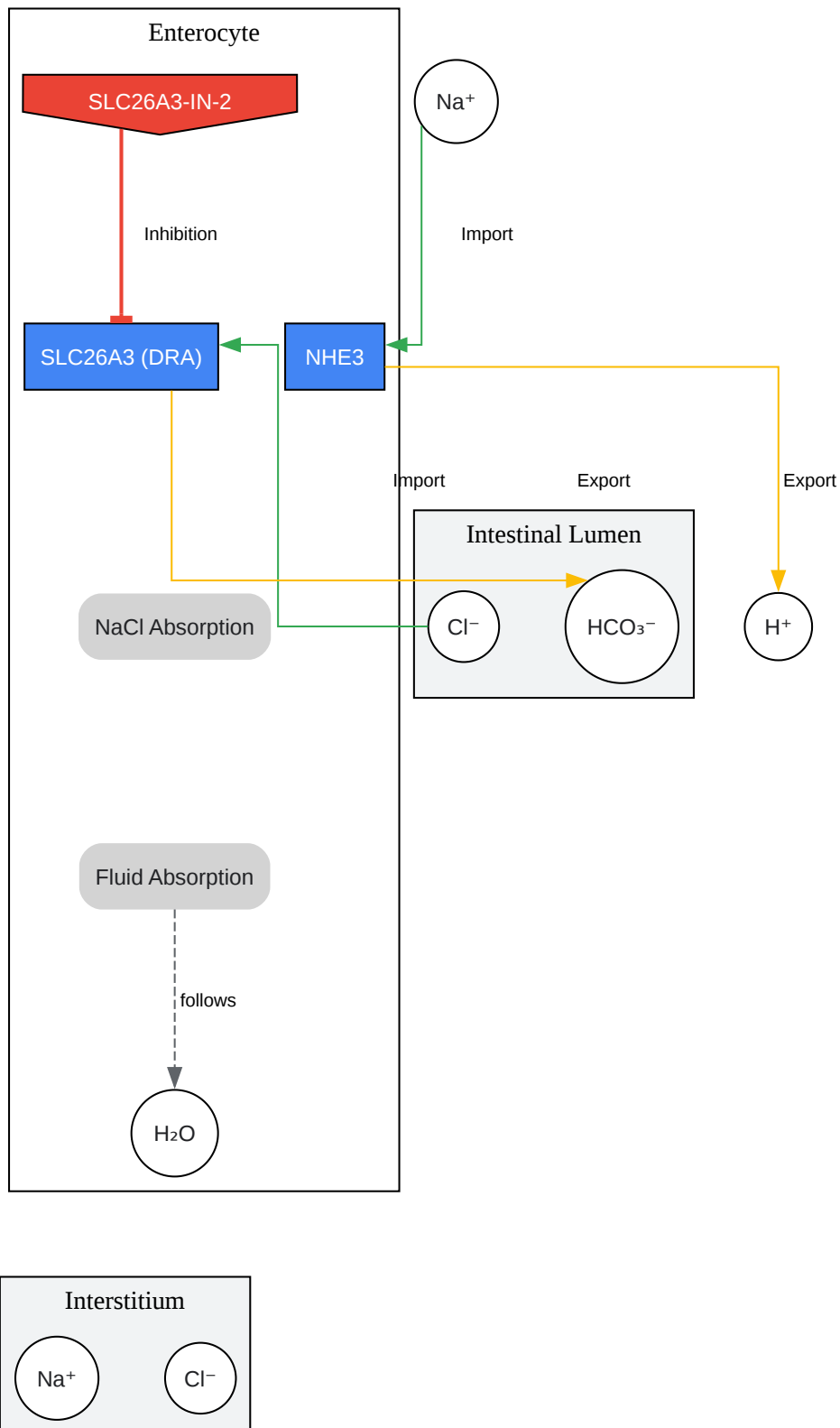

[Click to download full resolution via product page](#)

Caption: Intestinal ion transport and the inhibitory action of **SLC26A3-IN-2**.

Experimental Workflows

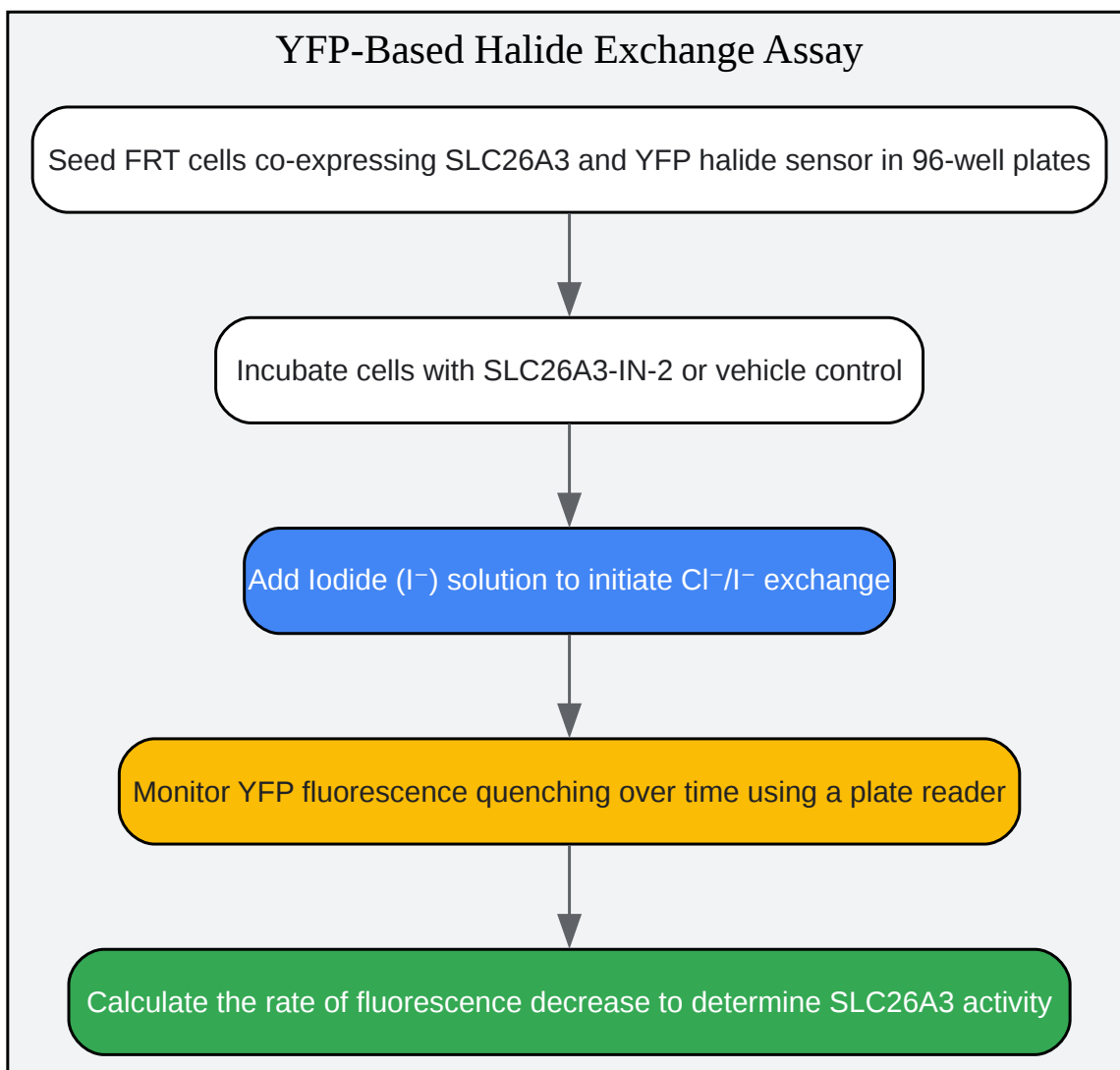

[Click to download full resolution via product page](#)

Caption: Workflow for the YFP-based halide exchange assay.

Ex Vivo Intestinal Fluid Transport Assay (Ussing Chamber)

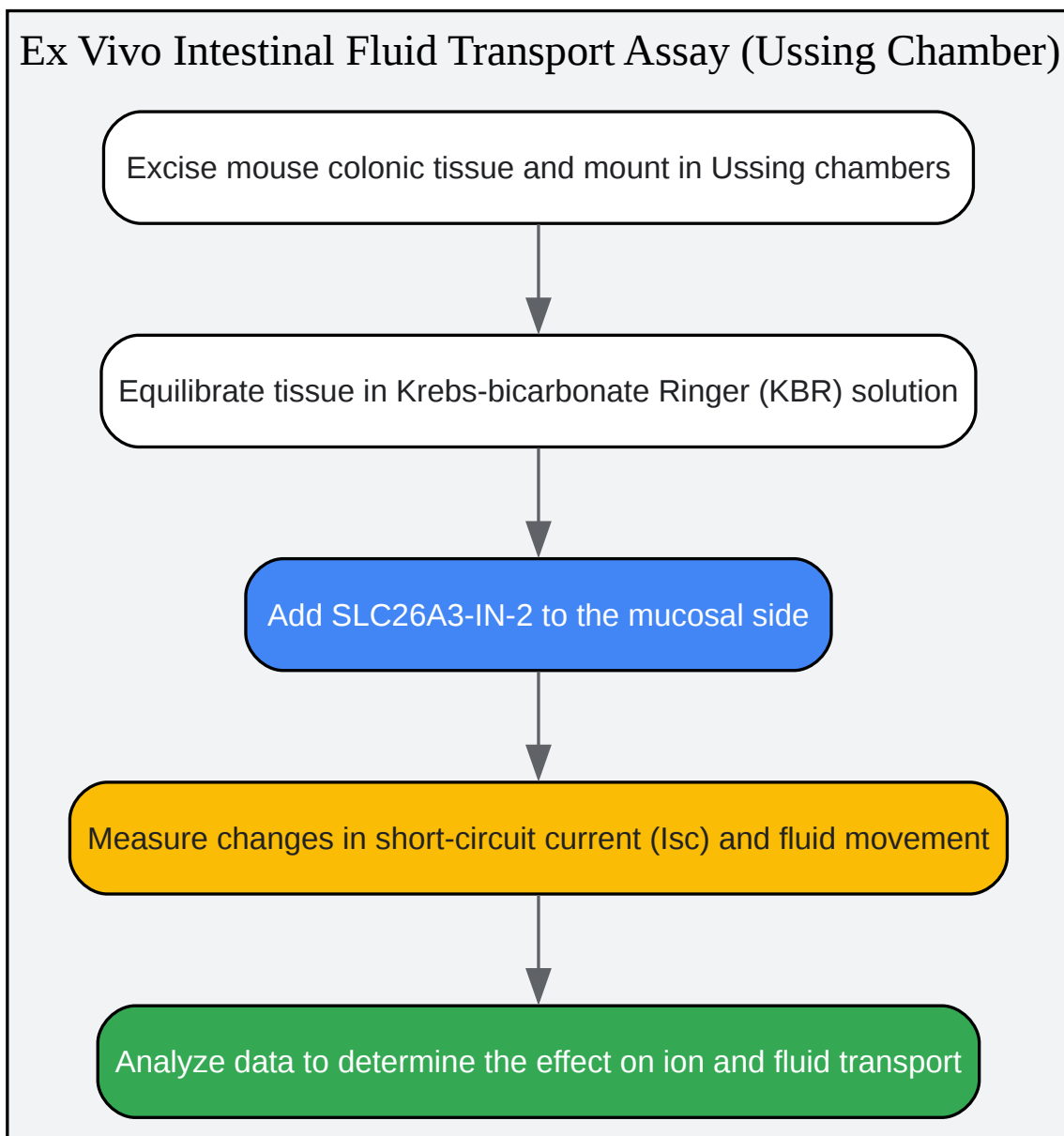

[Click to download full resolution via product page](#)

Caption: Workflow for the ex vivo Ussing chamber assay.

Experimental Protocols

In Vitro SLC26A3 Inhibition Assay using YFP-Based Halide Exchange

This protocol is adapted from high-throughput screening methods used to identify SLC26A3 inhibitors.[1][5]

Objective: To quantify the inhibitory effect of **SLC26A3-IN-2** on SLC26A3-mediated anion exchange in a cell-based assay.

Materials:

- Fischer Rat Thyroid (FRT) cells stably co-expressing human SLC26A3 and a halide-sensitive Yellow Fluorescent Protein (YFP-H148Q/I152L).[6][7]
- Cell culture medium (e.g., Coon's modified Ham's F-12 medium with 10% FBS, 2 mM L-glutamine, 100 U/mL penicillin, and 100 µg/mL streptomycin).
- Phosphate-Buffered Saline (PBS).
- Iodide solution (PBS with 100 mM NaI replacing 100 mM NaCl).
- **SLC26A3-IN-2** stock solution (in DMSO).
- 96-well black, clear-bottom microplates.
- Fluorescence plate reader with excitation at ~485 nm and emission at ~535 nm.

Procedure:

- Cell Seeding: Seed the FRT-SLC26A3-YFP cells into 96-well microplates at a density that results in a confluent monolayer on the day of the assay.
- Compound Incubation:
 - On the day of the assay, wash the cell monolayers twice with PBS.
 - Prepare serial dilutions of **SLC26A3-IN-2** in PBS. The final DMSO concentration should be kept constant across all wells (e.g., <0.5%).

- Add the **SLC26A3-IN-2** dilutions or vehicle control (PBS with DMSO) to the wells and incubate for 10-30 minutes at room temperature.
- Anion Exchange and Measurement:
 - Place the microplate in the fluorescence plate reader.
 - Establish a baseline fluorescence reading for 5-10 seconds.
 - Using the plate reader's injector, add an equal volume of the Iodide solution to each well to initiate the Cl^-/I^- exchange.
 - Immediately begin recording the YFP fluorescence quenching every 1-2 seconds for 1-2 minutes.
- Data Analysis:
 - The rate of fluorescence decrease is proportional to the SLC26A3-mediated iodide influx.
 - Calculate the initial rate of quenching for each well.
 - Normalize the rates to the vehicle control (100% activity) and a well with a known potent inhibitor or non-transfected cells (0% activity).
 - Plot the normalized activity against the concentration of **SLC26A3-IN-2** and fit the data to a dose-response curve to determine the IC_{50} .

Ex Vivo Intestinal Fluid Absorption Assay using Ussing Chambers

This protocol allows for the study of ion and fluid transport across an intact intestinal epithelium.

[\[4\]](#)[\[8\]](#)

Objective: To assess the effect of **SLC26A3-IN-2** on fluid absorption in isolated mouse colonic tissue.

Materials:

- Ussing chamber system with voltage-clamp apparatus.
- Krebs-bicarbonate Ringer (KBR) solution (in mM: 115 NaCl, 25 NaHCO₃, 2.4 K₂HPO₄, 0.4 KH₂PO₄, 1.2 CaCl₂, 1.2 MgCl₂, 10 D-glucose), gassed with 95% O₂/5% CO₂ to maintain pH 7.4.
- **SLC26A3-IN-2**.
- Laboratory mice.
- Surgical tools for tissue dissection.

Procedure:

- Tissue Preparation:
 - Humanely euthanize a mouse and excise a segment of the distal colon.
 - Open the segment along the mesenteric border and gently rinse with ice-cold KBR solution.
 - Remove the outer muscle layers by blunt dissection to obtain a mucosa-submucosa preparation.
- Ussing Chamber Mounting:
 - Mount the tissue preparation between the two halves of the Ussing chamber, separating the mucosal and serosal sides.
 - Fill both chambers with KBR solution and maintain at 37°C with continuous gassing.
- Equilibration and Measurement:
 - Allow the tissue to equilibrate for 30-60 minutes until a stable baseline short-circuit current (I_{sc}) is achieved. The I_{sc} is a measure of net ion transport across the epithelium.
 - After equilibration, add **SLC26A3-IN-2** to the mucosal chamber to the desired final concentration.

- Record the Isc continuously. A decrease in net ion absorption will be reflected in changes to the Isc.
- Fluid Transport Measurement:
 - Fluid movement can be measured by monitoring the change in volume in the mucosal and serosal reservoirs over time.
 - At the end of the experiment, calculate the net fluid flux. Inhibition of SLC26A3 is expected to decrease fluid absorption from the mucosal to the serosal side.
- Data Analysis:
 - Compare the changes in Isc and net fluid flux in tissues treated with **SLC26A3-IN-2** to vehicle-treated control tissues.
 - Statistical analysis (e.g., t-test or ANOVA) should be performed to determine the significance of the observed effects.

In Vivo Evaluation in a Loperamide-Induced Constipation Model

This protocol is for assessing the efficacy of **SLC26A3-IN-2** in a preclinical model of constipation.^{[3][4]}

Objective: To determine if oral administration of **SLC26A3-IN-2** can alleviate constipation in mice.

Materials:

- Laboratory mice (e.g., C57BL/6).
- Loperamide hydrochloride solution.
- **SLC26A3-IN-2** formulation for oral gavage.
- Metabolic cages for stool collection.

- Analytical balance.

Procedure:

- Induction of Constipation:
 - Administer loperamide (e.g., 5 mg/kg, intraperitoneally) to the mice to induce constipation. Loperamide inhibits intestinal motility.
- Compound Administration:
 - Shortly after loperamide administration, orally administer **SLC26A3-IN-2** or the vehicle control to different groups of mice.
- Stool Collection and Analysis:
 - Place the mice in individual metabolic cages with access to water but not food.
 - Collect all fecal pellets produced over a defined period (e.g., 3-6 hours).
 - Record the total number of pellets and the total wet weight of the stool for each mouse.
 - The stool water content can be determined by measuring the weight before and after drying the pellets in an oven.
- Data Analysis:
 - Compare the stool parameters (pellet number, wet weight, and water content) between the **SLC26A3-IN-2**-treated group and the vehicle-treated control group.
 - An increase in these parameters in the treated group indicates an anti-constipation effect.
 - Perform statistical analysis to determine the significance of the results.

Need Custom Synthesis?

BenchChem offers custom synthesis for rare earth carbides and specific isotopic labeling.

Email: info@benchchem.com or [Request Quote Online](#).

References

- 1. SLC26A3 inhibitor identified in small molecule screen blocks colonic fluid absorption and reduces constipation - PMC [[pmc.ncbi.nlm.nih.gov](https://pubmed.ncbi.nlm.nih.gov/)]
- 2. SLC26A3 (DRA, the Congenital Chloride Diarrhea Gene): A Novel Therapeutic Target for Diarrheal Diseases - PMC [[pmc.ncbi.nlm.nih.gov](https://pubmed.ncbi.nlm.nih.gov/)]
- 3. [medchemexpress.com](https://www.medchemexpress.com/) [[medchemexpress.com](https://www.medchemexpress.com/)]
- 4. SLC26A3 inhibitor identified in small molecule screen blocks colonic fluid absorption and reduces constipation - PubMed [pubmed.ncbi.nlm.nih.gov]
- 5. JCI Insight - SLC26A3 inhibitor identified in small molecule screen blocks colonic fluid absorption and reduces constipation [insight.jci.org]
- 6. Green fluorescent protein-based halide indicators with improved chloride and iodide affinities - PubMed [pubmed.ncbi.nlm.nih.gov]
- 7. [researchgate.net](https://www.researchgate.net/) [[researchgate.net](https://www.researchgate.net/)]
- 8. A guide to Ussing chamber studies of mouse intestine - PMC [[pmc.ncbi.nlm.nih.gov](https://pubmed.ncbi.nlm.nih.gov/)]
- To cite this document: BenchChem. [Application Notes and Protocols for SLC26A3-IN-2 Studies]. BenchChem, [2026]. [Online PDF]. Available at: [<https://www.benchchem.com/product/b10857102/docs#application-notes-and-protocols-for-slc26a3-in-2-studies>]

Disclaimer & Data Validity:

The information provided in this document is for Research Use Only (RUO) and is strictly not intended for diagnostic or therapeutic procedures. While BenchChem strives to provide accurate protocols, we make no warranties, express or implied, regarding the fitness of this product for every specific experimental setup.

Technical Support: The protocols provided are for reference purposes. Unsure if this reagent suits your experiment?

Need Industrial/Bulk Grade? [Request Custom Synthesis Quote](#)

BenchChem

Our mission is to be the trusted global source of essential and advanced chemicals, empowering scientists and researchers to drive progress in science and industry.

Contact

Address: 3281 E Guasti Rd

Ontario, CA 91761, United States

Phone: (601) 213-4426

Email: info@benchchem.com

[Contact our Ph.D. Support Team for a compatibility check](#)