

# Validating the Specificity of MU1742 in a Kinase Panel Screen: A Comparative Guide

**Author:** BenchChem Technical Support Team. **Date:** April 2026

## Compound of Interest

Compound Name: MU1742  
Cat. No.: B10856059

[Get Quote](#)

For researchers in kinase drug discovery and chemical biology, the specificity of a chemical probe is paramount for generating reliable experimental results. This guide provides a comprehensive comparison of the kinase inhibitor **MU1742** with alternative compounds, supported by experimental data to validate its specificity. **MU1742** is a potent and selective inhibitor of Casein Kinase 1 delta (CK1 $\delta$ ) and epsilon (CK1 $\epsilon$ ), two key regulators of various cellular processes, including the Wnt signaling pathway.<sup>[1][2]</sup>

## Comparative Kinase Selectivity

To objectively assess the specificity of **MU1742**, its activity was compared against a broad panel of kinases. Furthermore, its profile is contrasted with structurally analogous inhibitors, MU1250 and MU1500, which exhibit different isoform selectivity, and a negative control compound, MU2027.<sup>[1]</sup>

A kinome-wide screen of **MU1742** at a concentration of 1  $\mu$ M against 415 protein kinases demonstrated its high selectivity. The results showed that only CK1 isoforms were significantly inhibited, with no off-target kinases showing residual activity below 40%.<sup>[1][3]</sup>

The following table summarizes the in vitro potency (IC<sub>50</sub> values) of **MU1742** and its related compounds against key CK1 isoforms. This data allows for a direct comparison of their potency

and selectivity profiles.

Kinase Target	MU1742 IC50 (nM)	MU1250 IC50 (nM)	MU1500 IC50 (nM)	MU2027 (Negative Control) IC50 (nM)
CK1 $\alpha$	7.2[3]	-	-	>10,000[1]
CK1 $\delta$	6.1[3]	Selective for CK1 $\delta$ [4][5]	Dual CK1 $\delta/\epsilon$ inhibitor[4][5]	>10,000[1]
CK1 $\epsilon$	27.7[3]	-	Dual CK1 $\delta/\epsilon$ inhibitor[4][5]	>10,000[1]
CK1 $\alpha$ 1L	520[3]	-	-	-
p38 $\alpha$	>10,000[1]	-	-	>10,000[1]

Note: Specific IC50 values for MU1250 and MU1500 against a full kinase panel are not publicly available in a comparative format. The information provided reflects their described selectivity.

## Experimental Protocols

The following is a generalized protocol for a biochemical kinase assay used to determine the IC50 values of an inhibitor against a panel of kinases, based on methodologies employed by commercial providers like Reaction Biology.

Objective: To quantify the inhibitory potency of a test compound against a panel of purified kinases.

Materials:

- Purified recombinant kinases
- Specific peptide or protein substrates for each kinase
- Kinase reaction buffer (e.g., 50 mM HEPES, pH 7.5, 10 mM MgCl<sub>2</sub>, 1 mM EGTA, 2 mM DTT, 0.01% Tween-20)

- ATP solution (at a concentration near the  $K_m$  for each kinase, e.g., 10  $\mu\text{M}$ )
- [ $\gamma$ - $^{33}\text{P}$ ]ATP for radiometric detection
- Test compounds (e.g., **MU1742**) and control compounds (e.g., Staurosporine as a positive control, DMSO as a vehicle control)
- 96-well or 384-well assay plates
- Phosphocellulose or filter-binding plates (for radiometric assays)
- Scintillation counter or luminescence plate reader

#### Procedure:

- Compound Preparation: Prepare a serial dilution of the test inhibitor in DMSO.
- Reaction Setup:
  - In each well of the assay plate, add the kinase reaction buffer.
  - Add the specific kinase to each well.
  - Add the corresponding substrate to each well.
  - Add the diluted test inhibitor or control to the appropriate wells.
- Reaction Initiation: Start the kinase reaction by adding the ATP solution (containing a spike of [ $\gamma$ - $^{33}\text{P}$ ]ATP for radiometric assays).
- Incubation: Incubate the plate at a constant temperature (e.g., 30°C) for a predetermined time (e.g., 30-60 minutes).
- Reaction Termination and Detection:
  - Radiometric Assay: Stop the reaction by adding phosphoric acid. Transfer the reaction mixture to a filter-binding plate. Wash the plate to remove unincorporated [ $\gamma$ - $^{33}\text{P}$ ]ATP. Measure the incorporated radioactivity using a scintillation counter.

- Luminescence-Based Assay (e.g., ADP-Glo™): Stop the kinase reaction and measure the amount of ADP produced using a luminescence-based detection reagent and a plate reader.
- Data Analysis:
  - Calculate the percentage of kinase activity remaining at each inhibitor concentration relative to the vehicle control.
  - Plot the percent inhibition against the logarithm of the inhibitor concentration.
  - Fit the data to a sigmoidal dose-response curve to determine the IC50 value.

## Signaling Pathway and Experimental Workflow

To understand the biological context of **MU1742**'s activity, it is crucial to visualize its role in the relevant signaling pathways. CK1 $\delta$  and CK1 $\epsilon$  are key components of the Wnt signaling pathway, where they contribute to the phosphorylation and subsequent degradation of  $\beta$ -catenin.

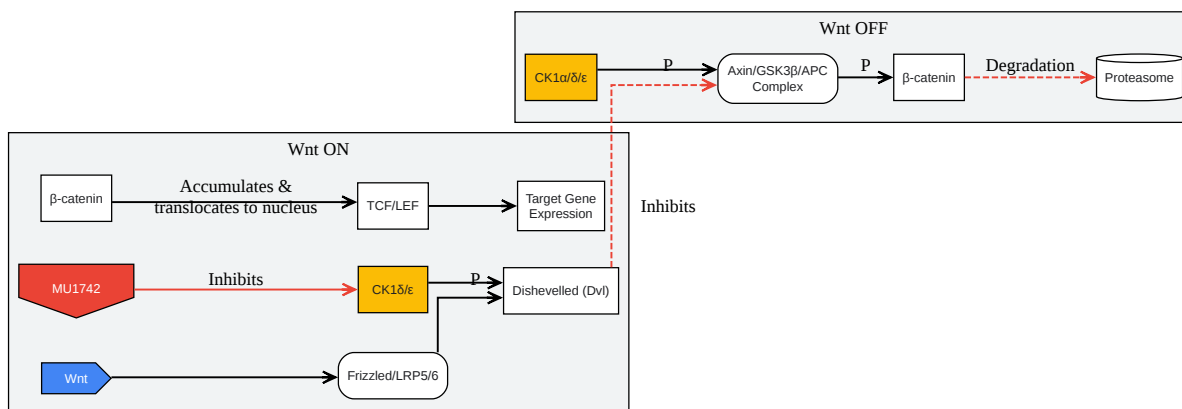

[Click to download full resolution via product page](#)

**Caption:** Wnt signaling pathway with **MU1742** inhibition. (Within 100 characters)

The following diagram illustrates a typical workflow for validating the specificity of a kinase inhibitor like **MU1742**.

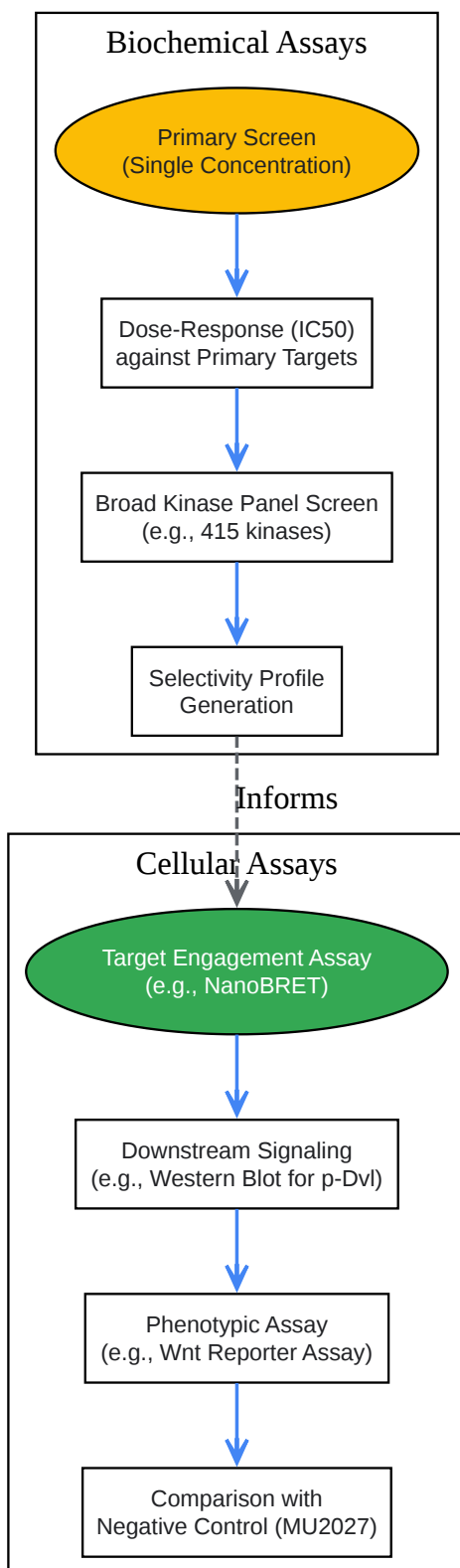

[Click to download full resolution via product page](#)

**Caption:** Workflow for validating kinase inhibitor specificity. (Within 100 characters)

### Need Custom Synthesis?

BenchChem offers custom synthesis for rare earth carbides and specific isotopic labeling.

Email: [info@benchchem.com](mailto:info@benchchem.com) or [Request Quote Online](#).

## References

- 1. MU1742 | Structural Genomics Consortium [[thesgc.org](https://thesgc.org)]
- 2. CASINVENT - SGC recommends the compound MU1742 as a new chemical probe for protein kinases CK1 $\delta$  and CK1 $\epsilon$ , developed in collaboration with the researchers of CasInvent Pharma, a.s. [[casinvent.com](https://casinvent.com)]
- 3. [eubopen.org](https://eubopen.org) [[eubopen.org](https://eubopen.org)]
- 4. [researchgate.net](https://researchgate.net) [[researchgate.net](https://researchgate.net)]
- 5. Discovery of Potent and Exquisitely Selective Inhibitors of Kinase CK1 with Tunable Isoform Selectivity - Section of Animal Physiology and Immunology [[ueb1.sci.muni.cz](https://ueb1.sci.muni.cz)]
- To cite this document: BenchChem. [Validating the Specificity of MU1742 in a Kinase Panel Screen: A Comparative Guide]. BenchChem, [2026]. [Online PDF]. Available at: [<https://www.benchchem.com/product/b10856059/docs#validating-the-specificity-of-mu1742-in-a-kinase-panel-screen-a-comparative-guide>]

---

### Disclaimer & Data Validity:

The information provided in this document is for Research Use Only (RUO) and is strictly not intended for diagnostic or therapeutic procedures. While BenchChem strives to provide accurate protocols, we make no warranties, express or implied, regarding the fitness of this product for every specific experimental setup.

**Technical Support:** The protocols provided are for reference purposes. Unsure if this reagent suits your experiment?

**Need Industrial/Bulk Grade?** [Request Custom Synthesis Quote](#)

# BenchChem

Our mission is to be the trusted global source of essential and advanced chemicals, empowering scientists and researchers to drive progress in science and industry.

## Contact

Address: 3281 E Guasti Rd

Ontario, CA 91761, United States

Phone: (601) 213-4426

Email: [info@benchchem.com](mailto:info@benchchem.com)

[Contact our Ph.D. Support Team for a compatibility check](#)