

The Role of IW927 in Inflammation Research: A Technical Guide

Author: BenchChem Technical Support Team. **Date:** May 2026

Compound of Interest

Compound Name: IW927
Cat. No.: B10856794

[Get Quote](#)

For Researchers, Scientists, and Drug Development Professionals

Executive Summary

IW927 is a small molecule inhibitor that plays a significant role in inflammation research by specifically targeting the interaction between Tumor Necrosis Factor-alpha (TNF- α) and its receptor, TNFR1. By disrupting this key signaling pathway, **IW927** effectively mitigates downstream inflammatory responses, including the activation of the NF- κ B pathway and the production of pro-inflammatory cytokines. This technical guide provides an in-depth overview of **IW927**, including its mechanism of action, quantitative data on its anti-inflammatory effects, detailed experimental protocols for its evaluation, and visualizations of the relevant biological pathways and experimental workflows.

Introduction to IW927 and its Mechanism of Action

IW927 is a photochemically-enhanced small molecule designed to inhibit the interaction between TNF- α and its primary signaling receptor, TNFR1.[1] This interaction is a critical initiating step in many inflammatory cascades. Unlike broad-spectrum anti-inflammatory agents, **IW927** offers a targeted approach by specifically preventing the binding of TNF- α to

TNFR1, thereby inhibiting the subsequent recruitment of downstream signaling proteins and the activation of pro-inflammatory transcription factors like NF- κ B.[1]

The binding of TNF- α to TNFR1 is a pivotal event in the inflammatory process, leading to the activation of signaling pathways that regulate cell survival, apoptosis, and inflammation. By blocking this initial step, **IW927** effectively suppresses the inflammatory cascade at its origin.

Quantitative Data on the Anti-inflammatory Efficacy of IW927

The anti-inflammatory properties of **IW927** have been quantified in various in vitro assays. The following table summarizes the key inhibitory concentrations (IC50) and dissociation constants (Kd) that demonstrate its potency.

Parameter	Value	Description	Reference
IC50 (TNF- α -TNFRc1 Binding)	50 nM	Concentration of IW927 required to inhibit 50% of TNF- α binding to the TNFR1 ectodomain (TNFRc1).	[1]
IC50 (I κ B Phosphorylation)	600 nM	Concentration of IW927 required to inhibit 50% of TNF- α -induced phosphorylation of I κ B, a key step in NF- κ B activation.	[1]
Kd (TNFRc1 Binding)	40-100 μ M	Dissociation constant for the reversible binding of IW927 to TNFRc1, indicating a weak initial affinity before photochemical enhancement.	[1]

Signaling Pathway of TNF- α -TNFR1 and **IW927** Intervention

The primary mechanism of action of **IW927** is the disruption of the TNF- α -TNFR1 signaling cascade, which ultimately prevents the activation of the NF- κ B pathway. A diagram of this pathway is presented below.

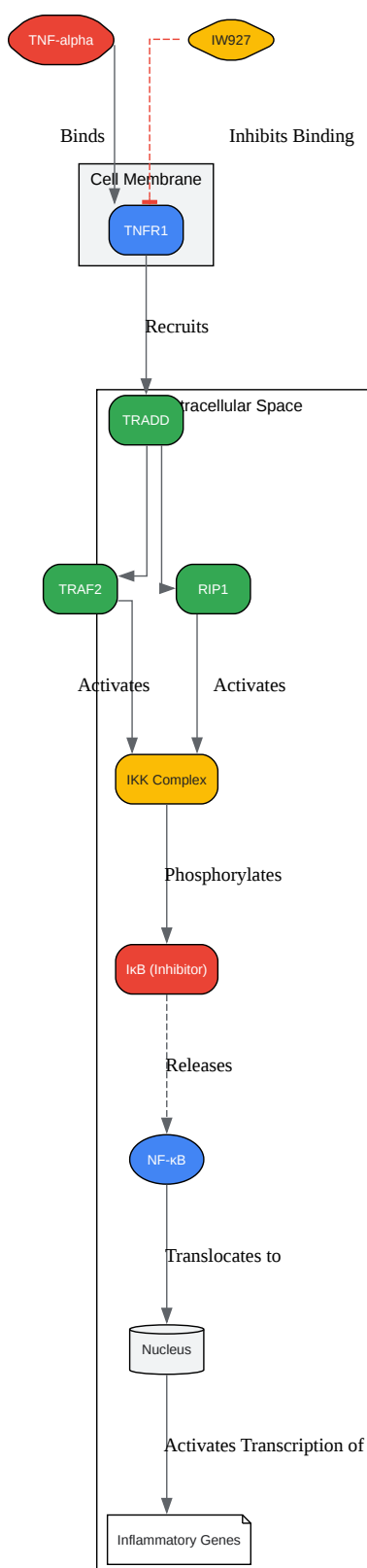

[Click to download full resolution via product page](#)

Figure 1: TNF-α-TNFR1 signaling pathway and the inhibitory action of **IW927**.

Detailed Experimental Protocols

To facilitate further research on **IW927**, this section provides detailed methodologies for key experiments.

TNF- α /TNFR1 Binding Assay

This protocol describes a competitive binding assay to quantify the ability of **IW927** to inhibit the interaction between TNF- α and TNFR1.

Materials:

- Recombinant human TNF- α
- Recombinant human TNFR1-Fc chimera
- **IW927**
- Assay buffer (e.g., PBS with 0.1% BSA)
- High-binding 96-well microplates
- HRP-conjugated anti-human IgG (Fc specific) antibody
- TMB substrate
- Stop solution (e.g., 2N H₂SO₄)
- Plate reader

Procedure:

- **Plate Coating:** Coat the wells of a 96-well microplate with 100 μ L of TNFR1-Fc at a concentration of 1 μ g/mL in PBS. Incubate overnight at 4°C.
- **Washing:** Wash the plate three times with 200 μ L of wash buffer (PBS with 0.05% Tween-20).

- Blocking: Block non-specific binding sites by adding 200 μL of blocking buffer (PBS with 1% BSA) to each well. Incubate for 1 hour at room temperature.
- Washing: Repeat the washing step.
- Compound Incubation: Prepare serial dilutions of **IW927** in assay buffer. Add 50 μL of each **IW927** dilution to the wells.
- TNF- α Addition: Add 50 μL of biotinylated TNF- α (at a concentration predetermined to be in the linear range of the assay) to each well.
- Incubation: Incubate for 2 hours at room temperature.
- Washing: Repeat the washing step.
- Detection: Add 100 μL of HRP-conjugated streptavidin diluted in assay buffer. Incubate for 1 hour at room temperature.
- Washing: Repeat the washing step.
- Substrate Addition: Add 100 μL of TMB substrate to each well. Incubate in the dark for 15-30 minutes.
- Stopping Reaction: Stop the reaction by adding 50 μL of stop solution.
- Data Acquisition: Read the absorbance at 450 nm using a microplate reader.
- Data Analysis: Calculate the percent inhibition for each concentration of **IW927** and determine the IC50 value.

NF- κB Activation Assay (Luciferase Reporter Assay)

This protocol details the measurement of NF- κB activation in response to TNF- α and its inhibition by **IW927** using a luciferase reporter gene assay in HEK293 cells.

Materials:

- HEK293 cells stably transfected with an NF- κB -luciferase reporter construct

- Cell culture medium (e.g., DMEM with 10% FBS)
- **IW927**
- Recombinant human TNF- α
- Luciferase assay reagent
- Luminometer

Procedure:

- **Cell Seeding:** Seed the HEK293-NF- κ B-luciferase reporter cells in a 96-well white, clear-bottom plate at a density of 5×10^4 cells/well. Allow cells to adhere overnight.
- **Compound Treatment:** Pre-treat the cells with various concentrations of **IW927** for 1 hour.
- **TNF- α Stimulation:** Stimulate the cells with TNF- α at a final concentration of 10 ng/mL. Include a vehicle control (no TNF- α) and a positive control (TNF- α alone).
- **Incubation:** Incubate the plate for 6 hours at 37°C in a CO2 incubator.
- **Luciferase Assay:** Lyse the cells and measure luciferase activity according to the manufacturer's instructions for the luciferase assay reagent.
- **Data Acquisition:** Read the luminescence using a luminometer.
- **Data Analysis:** Normalize the luciferase activity to a control for cell viability (e.g., a constitutively expressed reporter or a cell viability assay). Calculate the percent inhibition of TNF- α -induced NF- κ B activation for each **IW927** concentration and determine the IC50 value.

Western Blot for I κ B α Phosphorylation

This protocol describes the detection of phosphorylated I κ B α in cell lysates by Western blotting to assess the inhibitory effect of **IW927** on the NF- κ B signaling pathway.

Materials:

- RAW 264.7 macrophage cells
- Cell culture medium
- **IW927**
- LPS (Lipopolysaccharide)
- Lysis buffer (e.g., RIPA buffer with protease and phosphatase inhibitors)
- BCA protein assay kit
- SDS-PAGE gels
- PVDF membrane
- Transfer buffer
- Blocking buffer (e.g., 5% non-fat dry milk or BSA in TBST)
- Primary antibodies: anti-phospho-I κ B α (Ser32/36) and anti-I κ B α
- HRP-conjugated secondary antibody
- ECL Western blotting substrate
- Chemiluminescence imaging system

Procedure:

- Cell Culture and Treatment: Seed RAW 264.7 cells and grow to 80-90% confluency. Pre-treat cells with desired concentrations of **IW927** for 1 hour. Stimulate with LPS (100 ng/mL) for 15-30 minutes.
- Cell Lysis: Wash cells with ice-cold PBS and lyse with lysis buffer.
- Protein Quantification: Determine the protein concentration of the lysates using a BCA assay.
- SDS-PAGE: Denature protein samples and load equal amounts onto an SDS-PAGE gel.

- Electrotransfer: Transfer the separated proteins to a PVDF membrane.
- Blocking: Block the membrane with blocking buffer for 1 hour at room temperature.
- Primary Antibody Incubation: Incubate the membrane with the primary antibody against phospho-I κ B α overnight at 4°C.
- Washing: Wash the membrane three times with TBST.
- Secondary Antibody Incubation: Incubate with the HRP-conjugated secondary antibody for 1 hour at room temperature.
- Washing: Repeat the washing step.
- Detection: Add ECL substrate and visualize the protein bands using a chemiluminescence imaging system.
- Stripping and Re-probing: Strip the membrane and re-probe with an antibody against total I κ B α to confirm equal protein loading.

In Vivo Mouse Model of LPS-Induced Endotoxemia

This protocol outlines a common in vivo model to assess the anti-inflammatory efficacy of **IW927** in a systemic inflammation model.

Materials:

- BALB/c mice (8-10 weeks old)
- **IW927**
- LPS from *E. coli*
- Sterile saline
- ELISA kits for mouse TNF- α , IL-6, and IL-1 β

Procedure:

- **Animal Acclimatization:** Acclimatize mice for at least one week before the experiment.
- **Grouping and Dosing:** Randomly divide mice into groups (e.g., vehicle control, LPS + vehicle, LPS + **IW927** at different doses).
- **IW927 Administration:** Administer **IW927** or vehicle via a suitable route (e.g., intraperitoneal injection or oral gavage) at a predetermined time before LPS challenge.
- **LPS Challenge:** Induce endotoxemia by intraperitoneal injection of LPS (e.g., 5 mg/kg).
- **Sample Collection:** At a specified time point post-LPS injection (e.g., 2 hours for peak TNF- α), collect blood via cardiac puncture.
- **Cytokine Measurement:** Prepare serum from the blood samples and measure the concentrations of TNF- α , IL-6, and IL-1 β using ELISA kits according to the manufacturer's instructions.
- **Data Analysis:** Compare the cytokine levels between the different treatment groups to evaluate the in vivo anti-inflammatory effect of **IW927**.

Experimental Workflow Visualizations

The following diagrams illustrate the workflows for the key experimental protocols described above.

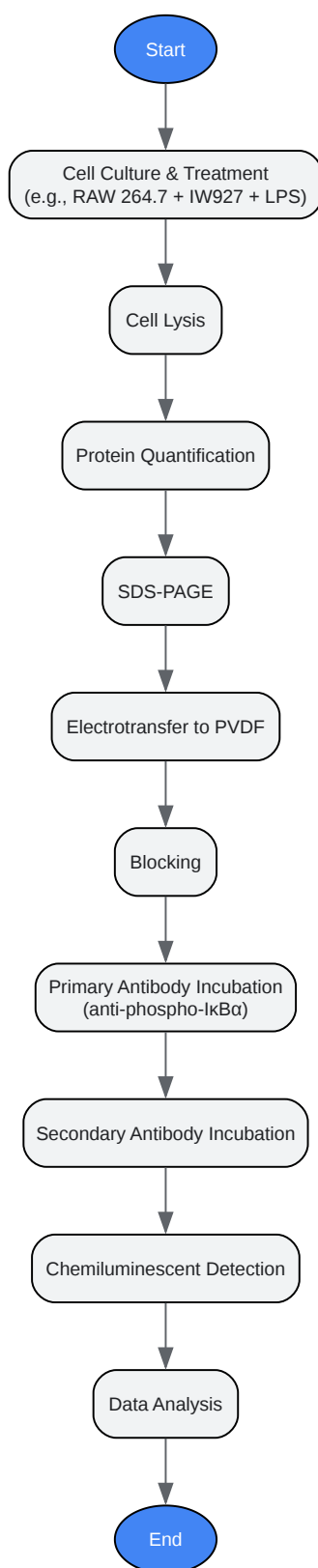

[Click to download full resolution via product page](#)

Figure 2: Workflow for Western Blot analysis of IκBα phosphorylation.

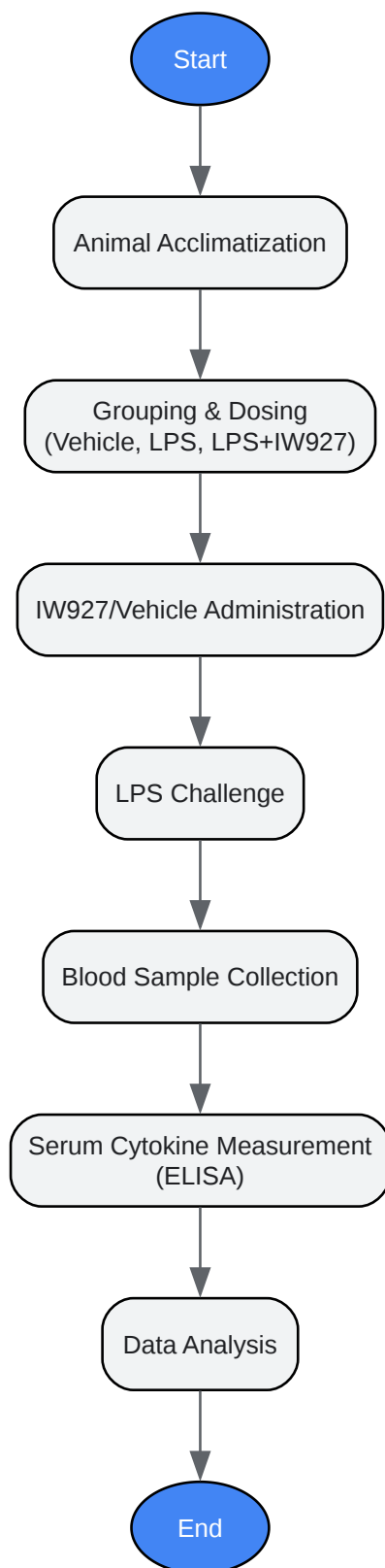

[Click to download full resolution via product page](#)

Need Custom Synthesis?

BenchChem offers custom synthesis for rare earth carbides and specific isotopic labeling.

Email: info@benchchem.com or [Request Quote Online](#).

References

- 1. [medchemexpress.com](https://www.medchemexpress.com) [[medchemexpress.com](https://www.medchemexpress.com)]
- To cite this document: BenchChem. [The Role of IW927 in Inflammation Research: A Technical Guide]. BenchChem, [2026]. [Online PDF]. Available at: [<https://www.benchchem.com/product/b10856794/docs#the-role-of-iw927-in-inflammation-research-a-technical-guide>]

Disclaimer & Data Validity:

The information provided in this document is for Research Use Only (RUO) and is strictly not intended for diagnostic or therapeutic procedures. While BenchChem strives to provide accurate protocols, we make no warranties, express or implied, regarding the fitness of this product for every specific experimental setup.

Technical Support: The protocols provided are for reference purposes. Unsure if this reagent suits your experiment?

Need Industrial/Bulk Grade? [Request Custom Synthesis Quote](#)

BenchChem

Our mission is to be the trusted global source of essential and advanced chemicals, empowering scientists and researchers to drive progress in science and industry.

Contact

Address: 3281 E Guasti Rd

Ontario, CA 91761, United States

Phone: (601) 213-4426

Email: info@benchchem.com

Contact our Ph.D. Support Team for a compatibility check