

In Vitro Characterization of BAY-805: A Technical Guide

Author: BenchChem Technical Support Team. **Date:** April 2026

Compound of Interest

Compound Name: BAY-805
Cat. No.: B10856275

[Get Quote](#)

For Researchers, Scientists, and Drug Development Professionals

This technical guide provides an in-depth overview of the in vitro characterization of **BAY-805**, a potent and selective non-covalent inhibitor of Ubiquitin-Specific Protease 21 (USP21).^{[1][2][3]} **BAY-805** serves as a valuable chemical probe for exploring the complex biology of USP21, a deubiquitinating enzyme (DUB) implicated in cancer development and growth.^{[1][4]} This document details the quantitative biochemical and cellular data, comprehensive experimental protocols for key assays, and visual representations of the relevant signaling pathway and experimental workflows.

Core Data Presentation

The following table summarizes the quantitative in vitro data for **BAY-805**, demonstrating its high potency and selectivity for USP21.

Assay Type	Parameter	Value (nM)	Target/System
Biochemical Assays			
HTRF Assay	IC50	6	hUSP21
Ub-Rhodamine Assay	IC50	2	hUSP21
Surface Plasmon Resonance (SPR)	Kd	2.2	hUSP21
Cellular Assays			
NF-κB Reporter Assay	EC50	17	HEK293T cells
HiBiT CETSA	EC50	95	HEK293T cells

Data compiled from multiple sources.[\[5\]](#)[\[6\]](#)[\[7\]](#)

Signaling Pathway

BAY-805 exerts its cellular effects by inhibiting USP21, which is known to deubiquitinate and inactivate Receptor-Interacting Protein 1 (RIP1).[\[3\]](#)[\[8\]](#) The inhibition of USP21 leads to an accumulation of K63-ubiquitinated RIP1, a critical step for the activation of the NF-κB signaling pathway.[\[3\]](#) This pathway plays a crucial role in inflammation, immunity, and cell survival.

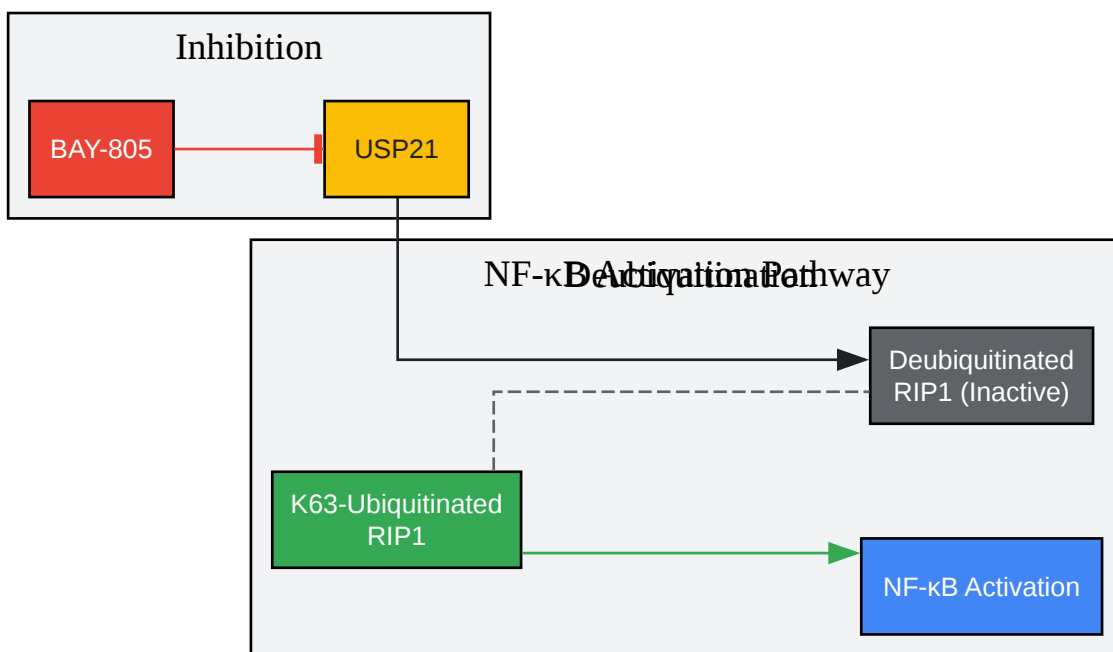

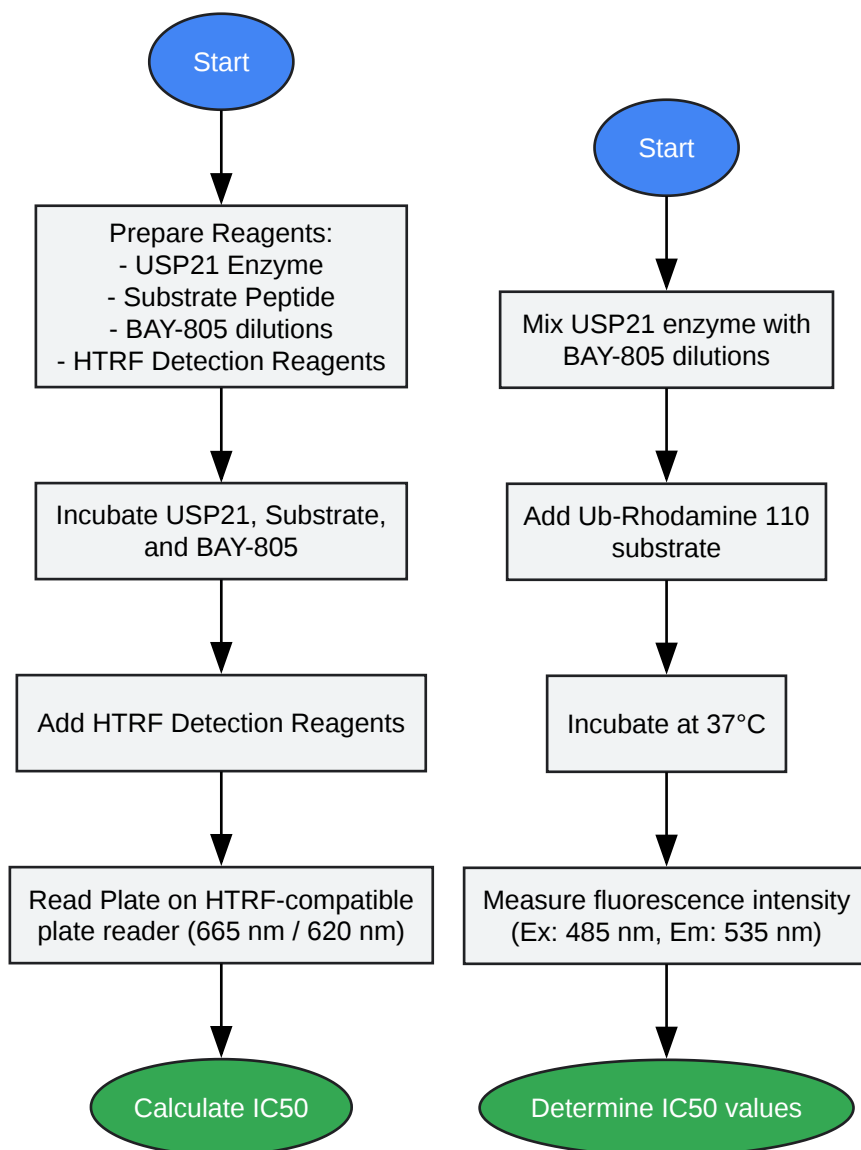

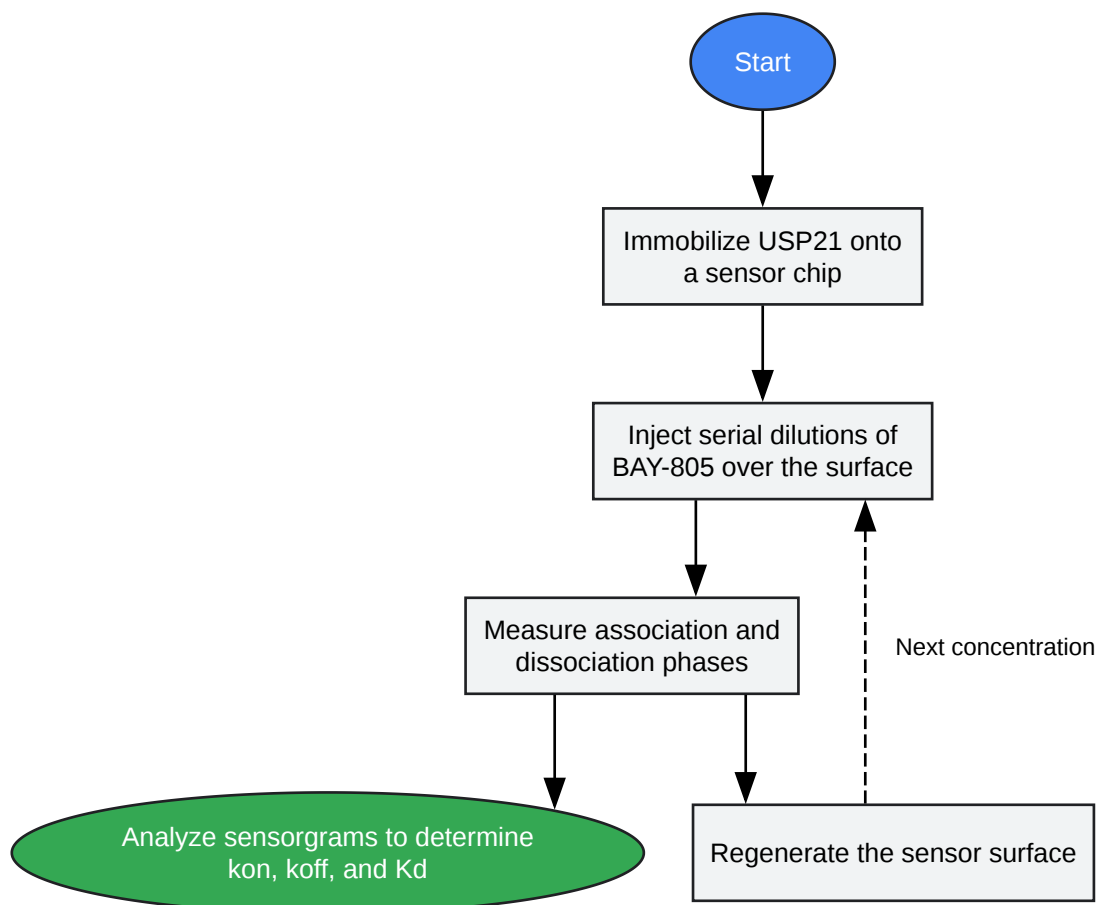

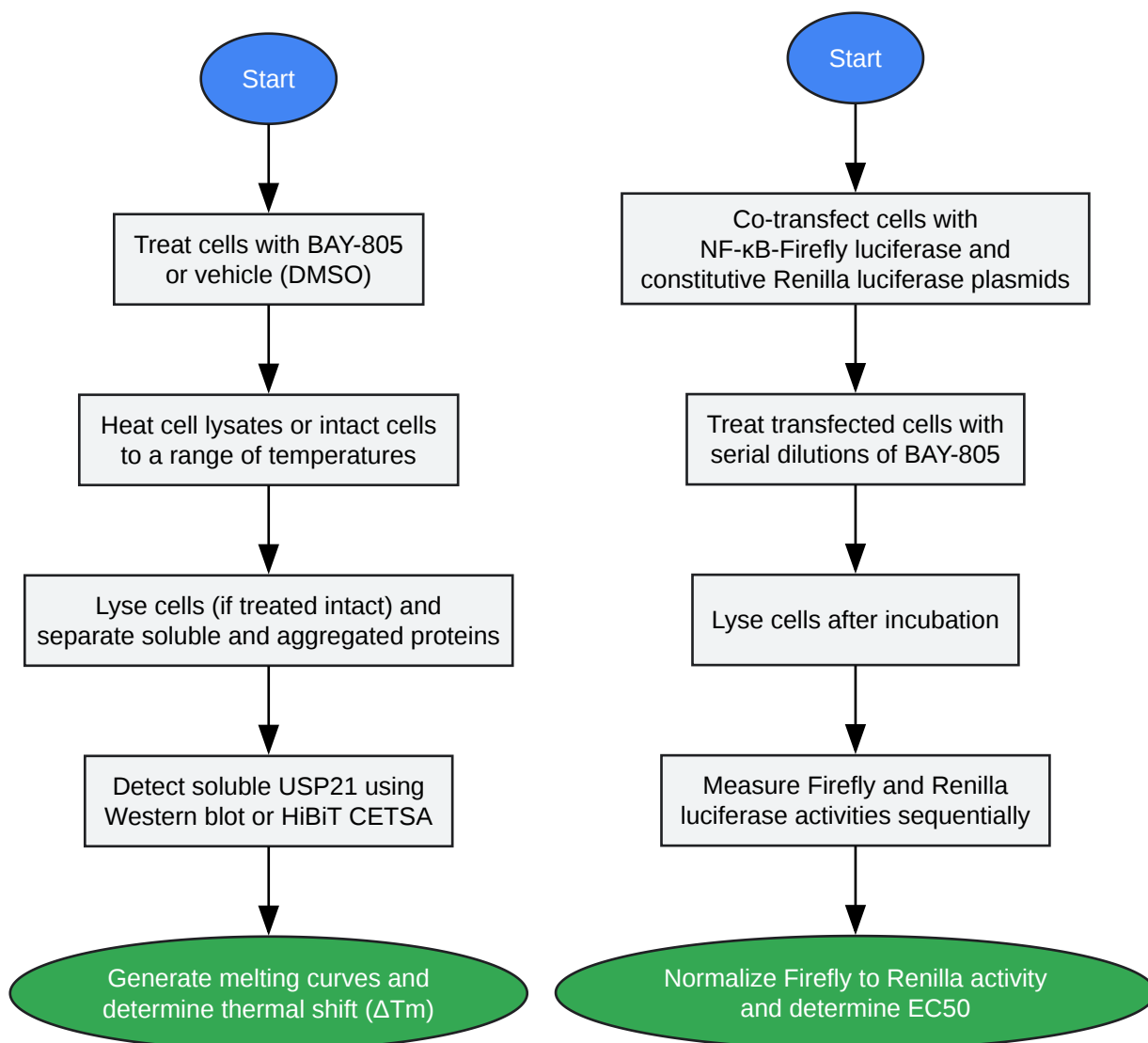

[Click to download full resolution via product page](#)

Need Custom Synthesis?

BenchChem offers custom synthesis for rare earth carbides and specific isotopic labeling.

Email: info@benchchem.com or [Request Quote Online](#).

References

- 1. Ubiquitin-specific Peptidase 21 Inhibits Tumor Necrosis Factor α -induced Nuclear Factor κ B Activation via Binding to and Deubiquitinating Receptor-interacting Protein 1 - PMC [pmc.ncbi.nlm.nih.gov]

- [2. ubiqbio.com \[ubiqbio.com\]](#)
- [3. Assay Systems for Profiling Deubiquitinating Activity - PMC \[pmc.ncbi.nlm.nih.gov\]](#)
- [4. CETSA \[cetsa.org\]](#)
- [5. lifesensors.com \[lifesensors.com\]](#)
- [6. liverpool.ac.uk \[liverpool.ac.uk\]](#)
- [7. researchgate.net \[researchgate.net\]](#)
- [8. Monitor NF- \$\kappa\$ B activation with dual luciferase reporter assay on SpectraMax iD5 \[moleculardevices.com\]](#)
- To cite this document: BenchChem. [In Vitro Characterization of BAY-805: A Technical Guide]. BenchChem, [2026]. [Online PDF]. Available at: [\[https://www.benchchem.com/product/b10856275/docs#in-vitro-characterization-of-bay-805-a-technical-guide\]](https://www.benchchem.com/product/b10856275/docs#in-vitro-characterization-of-bay-805-a-technical-guide)

Disclaimer & Data Validity:

The information provided in this document is for Research Use Only (RUO) and is strictly not intended for diagnostic or therapeutic procedures. While BenchChem strives to provide accurate protocols, we make no warranties, express or implied, regarding the fitness of this product for every specific experimental setup.

Technical Support: The protocols provided are for reference purposes. Unsure if this reagent suits your experiment?

Need Industrial/Bulk Grade? [Request Custom Synthesis Quote](#)

BenchChem

Our mission is to be the trusted global source of essential and advanced chemicals, empowering scientists and researchers to drive progress in science and industry.

Contact

Address: 3281 E Guasti Rd

Ontario, CA 91761, United States

Phone: (601) 213-4426

Email: info@benchchem.com

Contact our Ph.D. Support Team for a compatibility check