

In-Depth Technical Guide: CD73-IN-14 for Cancer Immunology Research

Author: BenchChem Technical Support Team. **Date:** April 2026

Compound of Interest

Compound Name: CD73-IN-14

Cat. No.: B10856132

[Get Quote](#)

For Researchers, Scientists, and Drug Development Professionals

Introduction

CD73-IN-14 has emerged as a potent and selective small molecule inhibitor of CD73, a critical ecto-enzyme in the adenosine signaling pathway. Within the tumor microenvironment (TME), CD73 plays a pivotal role in generating immunosuppressive adenosine, thereby enabling cancer cells to evade immune surveillance. By inhibiting CD73, **CD73-IN-14** represents a promising therapeutic strategy to restore anti-tumor immunity. This technical guide provides a comprehensive overview of **CD73-IN-14**, including its mechanism of action, biochemical and pharmacological properties, and detailed experimental protocols for its evaluation in cancer immunology research.

Core Properties of CD73-IN-14

CD73-IN-14 is an orally bioactive compound with high potency against the CD73 enzyme. Its inhibitory action leads to a reduction in adenosine production within the TME, which in turn enhances the activity of immune cells, particularly CD8+ T cells, leading to anti-tumor effects.

Quantitative Data Summary

Parameter	Value	Notes
IC50	0.17 nM	This value represents the half-maximal inhibitory concentration against CD73 enzymatic activity.
In Vivo Efficacy	Dose-dependent reduction in tumor volume	Specific details on the tumor models and dosing regimens are outlined in the experimental protocols section.
Immunomodulatory Effect	Increased number of activated CD8+ T cells in tumors	This highlights the compound's ability to enhance the adaptive immune response against cancer.
Chemical Feature	Contains an alkyne group	This functional group makes CD73-IN-14 suitable for "click chemistry" applications, allowing for its conjugation to other molecules for research purposes.

Mechanism of Action and Signaling Pathways

CD73, also known as ecto-5'-nucleotidase, is a cell surface enzyme that catalyzes the dephosphorylation of adenosine monophosphate (AMP) to adenosine.[1][2] In the TME, high levels of extracellular ATP are released from dying or stressed cells. This ATP is sequentially hydrolyzed to AMP by CD39, and then to adenosine by CD73.[1] Adenosine then binds to A2A and A2B receptors on various immune cells, including T cells and natural killer (NK) cells, triggering immunosuppressive signaling pathways.[1] This leads to decreased proliferation, cytokine release, and cytotoxic activity of these immune effector cells, ultimately allowing the tumor to escape immune destruction.[1]

CD73-IN-14 acts as a direct inhibitor of the enzymatic activity of CD73, thereby blocking the final and rate-limiting step in the production of extracellular adenosine.[3] This reduction in

adenosine levels alleviates the suppression of immune cells, restoring their ability to recognize and eliminate cancer cells.

CD73-Adenosine Signaling Pathway

The following diagram illustrates the canonical pathway of adenosine production in the tumor microenvironment and the point of intervention for **CD73-IN-14**.

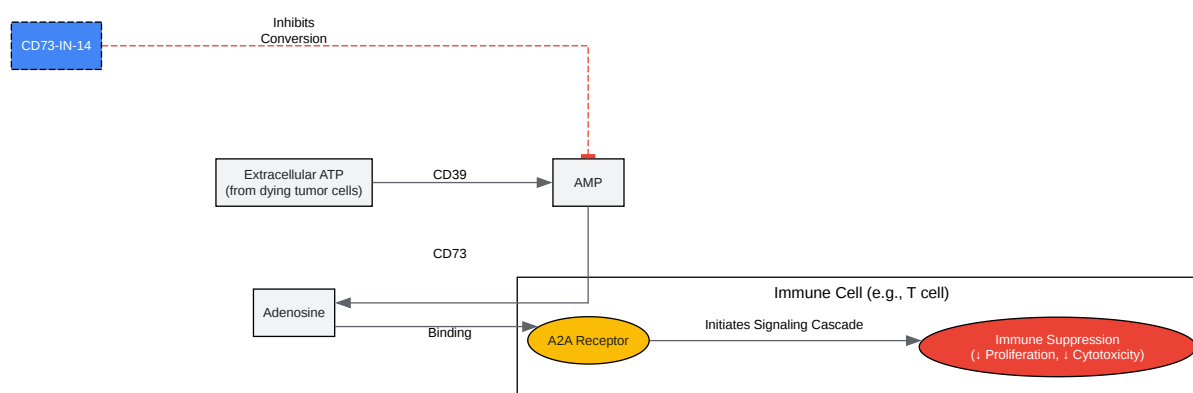

[Click to download full resolution via product page](#)

CD73-Adenosine production pathway and inhibition by **CD73-IN-14**.

Experimental Protocols

This section provides detailed methodologies for key experiments to evaluate the efficacy of **CD73-IN-14**.

In Vitro CD73 Enzymatic Activity Assay (IC50 Determination)

This protocol describes a common method to determine the IC₅₀ of a CD73 inhibitor using a biochemical assay that measures the amount of phosphate released from the hydrolysis of AMP.[4]

Materials:

- Recombinant human CD73 enzyme
- Adenosine 5'-monophosphate (AMP)
- **CD73-IN-14**
- Malachite Green Phosphate Assay Kit
- Assay buffer (e.g., Tris-buffered saline, pH 7.4)
- 96-well microplate

Procedure:

- Prepare a serial dilution of **CD73-IN-14** in the assay buffer.
- In a 96-well plate, add the recombinant CD73 enzyme to each well, except for the no-enzyme control wells.
- Add the serially diluted **CD73-IN-14** or vehicle control to the respective wells.
- Pre-incubate the plate at 37°C for 15-30 minutes.
- Initiate the enzymatic reaction by adding AMP to all wells. The final concentration of AMP should be close to its K_m value for CD73.
- Incubate the plate at 37°C for a specific time (e.g., 30-60 minutes), ensuring the reaction is in the linear range.
- Stop the reaction by adding the Malachite Green reagent according to the manufacturer's instructions. This reagent will react with the free phosphate generated from AMP hydrolysis.

- Measure the absorbance at the recommended wavelength (typically around 620-650 nm) using a microplate reader.
- Calculate the percentage of inhibition for each concentration of **CD73-IN-14** compared to the vehicle control.
- Determine the IC50 value by plotting the percentage of inhibition against the logarithm of the inhibitor concentration and fitting the data to a four-parameter logistic curve.

In Vivo Syngeneic Mouse Tumor Model

This protocol outlines a general procedure for evaluating the anti-tumor efficacy of orally administered **CD73-IN-14** in a syngeneic mouse model.^[5]

Materials:

- 6-8 week old female BALB/c or C57BL/6 mice (depending on the cell line)
- Syngeneic tumor cell line (e.g., CT26 for BALB/c, MC38 or B16F10 for C57BL/6)
- **CD73-IN-14**
- Vehicle for oral gavage (e.g., 0.5% methylcellulose in water)
- Calipers for tumor measurement
- Oral gavage needles

Procedure:

- Subcutaneously inject a suspension of tumor cells (e.g., 1×10^6 cells in 100 μ L of PBS) into the flank of each mouse.
- Allow the tumors to establish and reach a palpable size (e.g., 50-100 mm³).
- Randomize the mice into treatment and control groups.
- Prepare the dosing solution of **CD73-IN-14** in the appropriate vehicle.

- Administer **CD73-IN-14** or vehicle control to the respective groups via oral gavage at the desired dose and schedule (e.g., once daily).
- Measure the tumor dimensions (length and width) with calipers every 2-3 days and calculate the tumor volume using the formula: $(\text{Length} \times \text{Width}^2) / 2$.
- Monitor the body weight of the mice as an indicator of toxicity.
- Continue the treatment for the duration of the study (e.g., 2-3 weeks) or until the tumors in the control group reach a predetermined endpoint.
- At the end of the study, euthanize the mice and excise the tumors for further analysis (e.g., weight measurement, flow cytometry).
- Plot the mean tumor volume over time for each group to assess the anti-tumor efficacy.

Flow Cytometry Analysis of Tumor-Infiltrating Lymphocytes (TILs)

This protocol describes the isolation and analysis of TILs from tumor tissues to evaluate the effect of **CD73-IN-14** on the immune cell composition, particularly the activation status of CD8+ T cells.

Materials:

- Freshly excised tumors from the in vivo study
- RPMI-1640 medium
- Fetal Bovine Serum (FBS)
- Collagenase D, Hyaluronidase, and DNase I
- FACS buffer (PBS with 2% FBS)
- Red Blood Cell Lysis Buffer
- 70 μm cell strainers

- Fluorescently labeled antibodies against immune cell markers (e.g., CD45, CD3, CD8, CD4, Granzyme B, Ki-67, PD-1)
- Flow cytometer

Procedure:

- Mince the excised tumors into small pieces in a petri dish containing RPMI-1640 medium.
- Transfer the minced tissue to a digestion buffer containing Collagenase D, Hyaluronidase, and DNase I.
- Incubate at 37°C for 30-60 minutes with gentle agitation.
- Neutralize the digestion by adding RPMI-1640 with FBS.
- Filter the cell suspension through a 70 µm cell strainer to obtain a single-cell suspension.
- Lyse red blood cells using a lysis buffer.
- Wash the cells with FACS buffer and count them.
- Stain the cells with a cocktail of fluorescently labeled antibodies against the desired surface and intracellular markers. For intracellular staining, a fixation and permeabilization step is required.
- Acquire the stained cells on a flow cytometer.
- Analyze the data using flow cytometry analysis software to quantify the populations of different immune cells and their activation status (e.g., percentage of CD8+ T cells expressing Granzyme B or Ki-67).

Experimental Workflow for Preclinical Evaluation of CD73-IN-14

The following diagram outlines a typical workflow for the preclinical assessment of a CD73 inhibitor like **CD73-IN-14**.

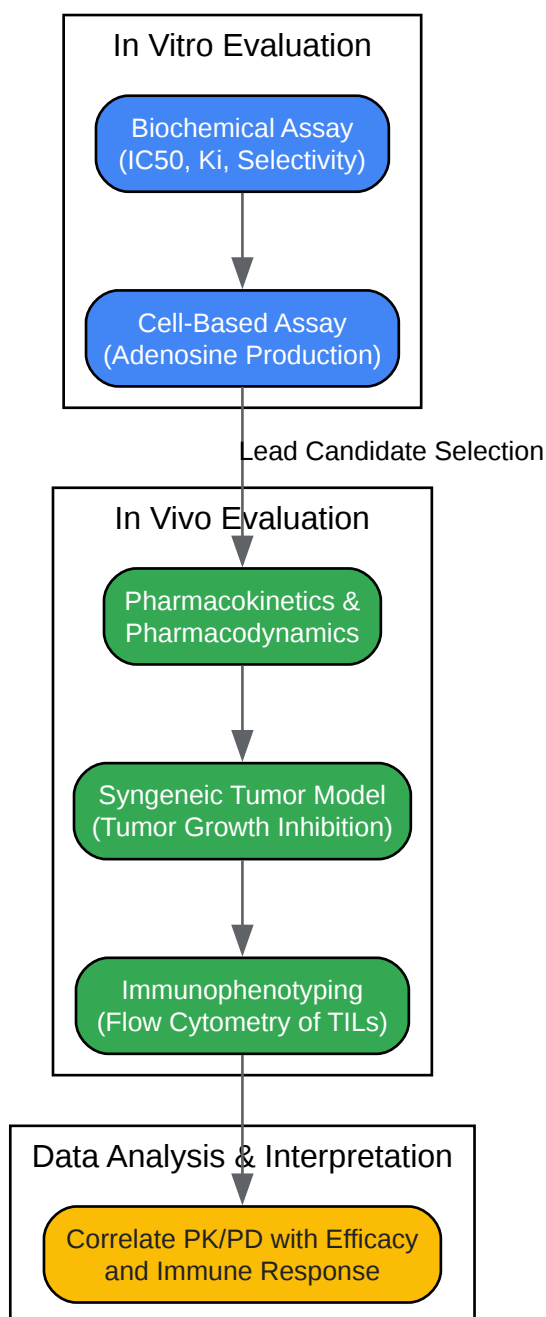

[Click to download full resolution via product page](#)

Preclinical evaluation workflow for a CD73 inhibitor.

Conclusion

CD73-IN-14 is a potent and specific inhibitor of CD73 with promising anti-tumor activity driven by the restoration of immune function within the tumor microenvironment. The data and

protocols presented in this guide provide a solid foundation for researchers and drug development professionals to further investigate the therapeutic potential of **CD73-IN-14** in cancer immunology. Further studies are warranted to fully elucidate its pharmacokinetic profile, long-term efficacy, and potential for combination therapies with other immunomodulatory agents.

Need Custom Synthesis?

BenchChem offers custom synthesis for rare earth carbides and specific isotopic labeling.

Email: info@benchchem.com or [Request Quote Online](#).

References

- [1. ouv.vt.edu \[ouv.vt.edu\]](http://ouv.vt.edu)
- [2. iacuc.ucsf.edu \[iacuc.ucsf.edu\]](http://iacuc.ucsf.edu)
- [3. CD73-IN-14 | CD73 | 2407356-67-4 | Invivochem \[invivochem.com\]](#)
- [4. Monitoring and characterizing soluble and membrane-bound ectonucleotidases CD73 and CD39 - PMC \[pmc.ncbi.nlm.nih.gov\]](#)
- [5. uac.arizona.edu \[uac.arizona.edu\]](http://uac.arizona.edu)
- To cite this document: BenchChem. [In-Depth Technical Guide: CD73-IN-14 for Cancer Immunology Research]. BenchChem, [2026]. [Online PDF]. Available at: [\[https://www.benchchem.com/product/b10856132/docs#in-depth-technical-guide-cd73-in-14-for-cancer-immunology-research\]](https://www.benchchem.com/product/b10856132/docs#in-depth-technical-guide-cd73-in-14-for-cancer-immunology-research)

Disclaimer & Data Validity:

The information provided in this document is for Research Use Only (RUO) and is strictly not intended for diagnostic or therapeutic procedures. While BenchChem strives to provide accurate protocols, we make no warranties, express or implied, regarding the fitness of this product for every specific experimental setup.

Technical Support: The protocols provided are for reference purposes. Unsure if this reagent suits your experiment?

Need Industrial/Bulk Grade? [Request Custom Synthesis Quote](#)

BenchChem

Our mission is to be the trusted global source of essential and advanced chemicals, empowering scientists and researchers to drive progress in science and industry.

Contact

Address: 3281 E Guasti Rd
Ontario, CA 91761, United States
Phone: (601) 213-4426
Email: info@benchchem.com

[Contact our Ph.D. Support Team for a compatibility check](#)