

Application Notes and Protocols for Click Chemistry in PROTAC Synthesis: Targeting BRD4

Author: BenchChem Technical Support Team. **Date:** April 2026

Compound of Interest

Compound Name: PROTAC BRD4-binding moiety 1

CAS No.: 2101200-10-4

Cat. No.: B10856715

[Get Quote](#)

For Researchers, Scientists, and Drug Development Professionals

Introduction

Proteolysis-targeting chimeras (PROTACs) are a revolutionary class of therapeutic agents that utilize the cell's own ubiquitin-proteasome system to selectively degrade target proteins.[1] The modular nature of PROTACs, consisting of a target-binding ligand, an E3 ligase-recruiting ligand, and a connecting linker, lends itself to versatile synthetic strategies. Among these, "click chemistry," particularly the copper(I)-catalyzed azide-alkyne cycloaddition (CuAAC), has emerged as a powerful tool for the rapid and efficient synthesis of PROTAC libraries.[2] This approach offers high yields, mild reaction conditions, and exceptional functional group tolerance.[3]

This document provides detailed protocols for the synthesis of a BRD4-binding moiety equipped with a "click-ready" alkyne handle, specifically a propargylamide derivative of the well-characterized BRD4 inhibitor, (+)-JQ1. Subsequently, a protocol for the CuAAC reaction to

conjugate this moiety to an azide-functionalized linker connected to an E3 ligase ligand is described.

Data Presentation

The following table summarizes representative quantitative data for the key synthetic steps involved in the preparation of a BRD4-targeting PROTAC via click chemistry.

Step	Reaction	Starting Materials	Key Reagents	Solvent	Temp. (°C)	Time (h)	Yield (%)	Purity (%)	Analytical Method
1	Hydrolysis	(+)-JQ1-t-butyl ester	LiOH or TFA	THF/H ₂ O or DCM	RT	2-4	>95	>98	LC-MS, ¹ H NMR
2	Amidation	(+)-JQ1-carboxylic acid, Propargylamine	HATU, DIPEA	DMF	RT	12-16	75-90	>95	LC-MS, ¹ H NMR
3	CuAAC	(+)-JQ1-propargylamide, Azide-linker-E3 ligand	CuSO ₄ ·5H ₂ O, Sodium Ascorbate, TBTA	tBuOH/H ₂ O	RT	1-4	55-90	>98	LC-MS, ¹ H NMR, HPLC

Note: Yields and purity are representative and may vary depending on the specific substrates and reaction conditions.

Experimental Protocols

Protocol 1: Synthesis of BRD4-Binding Moiety 1 ((+)-JQ1 Propargylamide)

This protocol describes the two-step synthesis of a BRD4-binding moiety functionalized with a terminal alkyne for subsequent click chemistry. The synthesis starts from the readily available (+)-JQ1, which is first converted to its carboxylic acid derivative, followed by an amide coupling with propargylamine.

Step 1: Synthesis of (+)-JQ1 Carboxylic Acid

The tert-butyl ester of (+)-JQ1 is hydrolyzed to the corresponding carboxylic acid.

Materials:

- (+)-JQ1-t-butyl ester
- Trifluoroacetic acid (TFA)
- Dichloromethane (DCM)
- Sodium bicarbonate (NaHCO_3), saturated aqueous solution
- Brine
- Anhydrous sodium sulfate (Na_2SO_4)
- Rotary evaporator
- Standard laboratory glassware

Procedure:

- Dissolve (+)-JQ1-t-butyl ester (1.0 eq) in dichloromethane (DCM).

- Add trifluoroacetic acid (TFA) (10-20 eq) dropwise to the solution at room temperature.
- Stir the reaction mixture at room temperature for 2-4 hours, monitoring the reaction progress by TLC or LC-MS.
- Upon completion, concentrate the reaction mixture under reduced pressure using a rotary evaporator.
- Redissolve the residue in DCM and wash with a saturated aqueous solution of NaHCO_3 to neutralize excess TFA.
- Wash the organic layer with brine, dry over anhydrous Na_2SO_4 , filter, and concentrate in vacuo to yield (+)-JQ1 carboxylic acid as a solid. The product is typically used in the next step without further purification.

Step 2: Amide Coupling with Propargylamine

The (+)-JQ1 carboxylic acid is coupled with propargylamine to introduce the terminal alkyne handle.

Materials:

- (+)-JQ1 carboxylic acid
- Propargylamine
- HATU (1-[Bis(dimethylamino)methylene]-1H-1,2,3-triazolo[4,5-b]pyridinium 3-oxid hexafluorophosphate)
- DIPEA (N,N-Diisopropylethylamine)
- Anhydrous N,N-Dimethylformamide (DMF)
- Ethyl acetate (EtOAc)
- Saturated aqueous solution of NaHCO_3
- Brine

- Anhydrous Na_2SO_4
- Silica gel for column chromatography
- Standard laboratory glassware

Procedure:

- Dissolve (+)-JQ1 carboxylic acid (1.0 eq) in anhydrous DMF.
- Add HATU (1.2 eq) and DIPEA (3.0 eq) to the solution and stir for 15 minutes at room temperature to activate the carboxylic acid.
- Add propargylamine (1.5 eq) to the reaction mixture.
- Stir the reaction at room temperature for 12-16 hours. Monitor the reaction progress by TLC or LC-MS.
- Upon completion, dilute the reaction mixture with ethyl acetate and wash with saturated aqueous NaHCO_3 solution and then with brine.
- Dry the organic layer over anhydrous Na_2SO_4 , filter, and concentrate under reduced pressure.
- Purify the crude product by silica gel column chromatography to obtain the desired (+)-JQ1 propargylamide (BRD4-binding moiety 1).
- Characterize the final product by ^1H NMR, ^{13}C NMR, and high-resolution mass spectrometry (HRMS).

Protocol 2: Click Chemistry for PROTAC Synthesis (CuAAC Reaction)

This protocol details the copper(I)-catalyzed azide-alkyne cycloaddition (CuAAC) to conjugate the alkyne-functionalized BRD4-binding moiety with an azide-containing linker-E3 ligase ligand moiety.

Materials:

- (+)-JQ1 propargylamide (BRD4-binding moiety 1)
- Azide-functionalized linker-E3 ligase ligand
- Copper(II) sulfate pentahydrate ($\text{CuSO}_4 \cdot 5\text{H}_2\text{O}$)
- Sodium ascorbate
- Tris(benzyltriazolylmethyl)amine (TBTA)
- tert-Butanol (tBuOH)
- Deionized water
- Reverse-phase HPLC for purification
- Standard laboratory glassware

Procedure:

- In a suitable reaction vial, dissolve the (+)-JQ1 propargylamide (1.0 eq) and the azide-functionalized linker-E3 ligase ligand (1.1 eq) in a 1:1 mixture of tBuOH and deionized water.
- In a separate vial, prepare a fresh solution of sodium ascorbate (0.5 eq) in deionized water.
- In another vial, prepare a solution of $\text{CuSO}_4 \cdot 5\text{H}_2\text{O}$ (0.1 eq) and TBTA (0.1 eq) in a 1:1 mixture of tBuOH and deionized water.
- Add the CuSO_4 /TBTA solution to the solution containing the alkyne and azide.
- Initiate the reaction by adding the sodium ascorbate solution.
- Stir the reaction mixture vigorously at room temperature for 1-4 hours. The reaction is often complete within this timeframe. Monitor the progress by LC-MS.
- Upon completion, dilute the reaction mixture with a suitable solvent system (e.g., DMSO/water) and purify the final PROTAC product by reverse-phase HPLC.
- Characterize the purified PROTAC by ^1H NMR, ^{13}C NMR, and HRMS.

Visualizations

The following diagrams illustrate the synthetic workflow and the PROTAC mechanism of action.

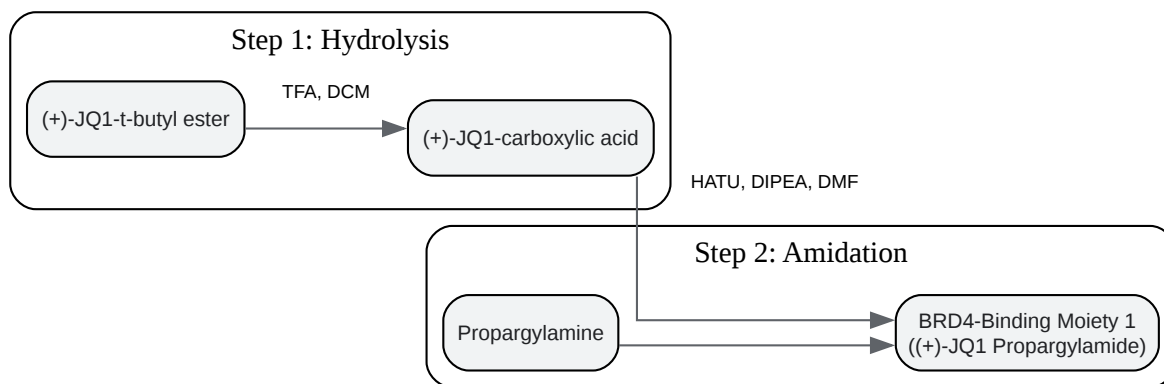

[Click to download full resolution via product page](#)

Caption: Synthetic scheme for the BRD4-binding moiety.

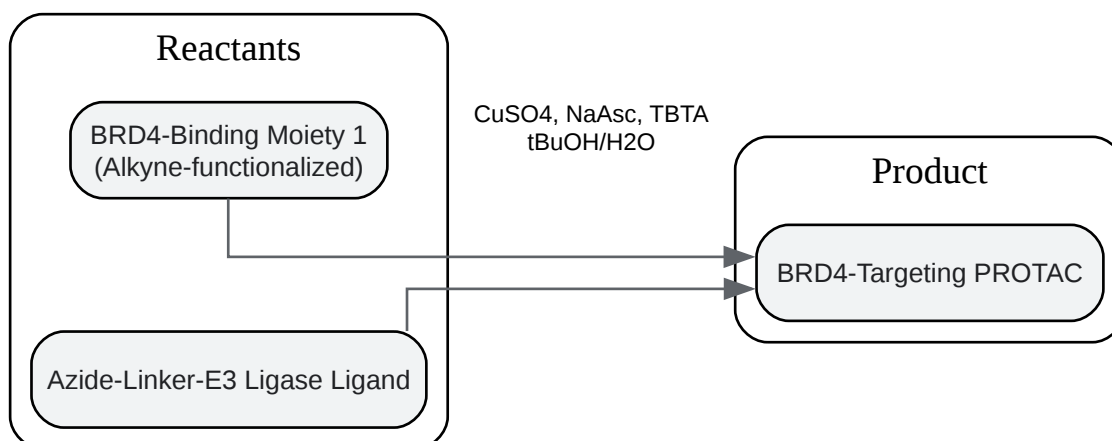

[Click to download full resolution via product page](#)

Caption: CuAAC for BRD4-targeting PROTAC synthesis.

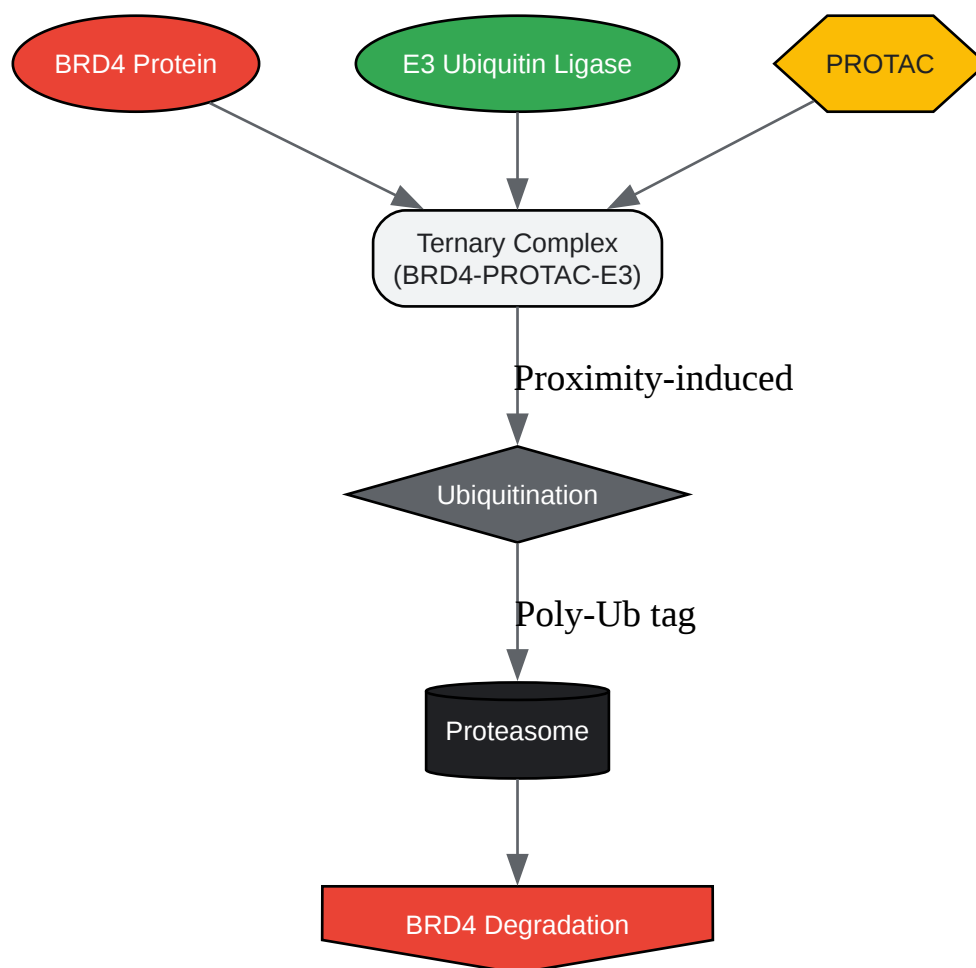

[Click to download full resolution via product page](#)

Caption: Mechanism of action for a BRD4-targeting PROTAC.

Need Custom Synthesis?

BenchChem offers custom synthesis for rare earth carbides and specific isotopic labeling.

Email: info@benchchem.com or [Request Quote Online](#).

References

- 1. Scalable syntheses of the BET bromodomain inhibitor JQ1 - PMC [[pmc.ncbi.nlm.nih.gov](https://pubmed.ncbi.nlm.nih.gov/)]
- 2. Click chemistry in the development of PROTACs - RSC Chemical Biology (RSC Publishing) DOI:10.1039/D3CB00199G [pubs.rsc.org]

- [3. bioclone.net \[bioclone.net\]](https://www.bioclone.net)
- To cite this document: BenchChem. [Application Notes and Protocols for Click Chemistry in PROTAC Synthesis: Targeting BRD4]. BenchChem, [2026]. [Online PDF]. Available at: [<https://www.benchchem.com/product/b10856715/docs#application-notes-and-protocols-for-click-chemistry-in-protac-synthesis-targeting-brd4>]

Disclaimer & Data Validity:

The information provided in this document is for Research Use Only (RUO) and is strictly not intended for diagnostic or therapeutic procedures. While BenchChem strives to provide accurate protocols, we make no warranties, express or implied, regarding the fitness of this product for every specific experimental setup.

Technical Support: The protocols provided are for reference purposes. Unsure if this reagent suits your experiment?

Need Industrial/Bulk Grade? [Request Custom Synthesis Quote](#)

BenchChem

Our mission is to be the trusted global source of essential and advanced chemicals, empowering scientists and researchers to drive progress in science and industry.

Contact

Address: 3281 E Guasti Rd
Ontario, CA 91761, United States
Phone: (601) 213-4426
Email: info@benchchem.com

[Contact our Ph.D. Support Team for a compatibility check](#)