

# Application Notes and Protocols for In Vitro Evaluation of Pcsk9-IN-10

**Author:** BenchChem Technical Support Team. **Date:** April 2026

## Compound of Interest

Compound Name: *Pcsk9-IN-10*

Cat. No.: *B10855127*

[Get Quote](#)

For Researchers, Scientists, and Drug Development Professionals

## Introduction

Proprotein Convertase Subtilisin/Kexin type 9 (PCSK9) is a key regulator of cholesterol metabolism. It functions by binding to the Low-Density Lipoprotein Receptor (LDLR) on the surface of hepatocytes, targeting it for lysosomal degradation.[1][2][3] This process reduces the number of LDLRs available to clear circulating LDL cholesterol (LDL-C) from the bloodstream, leading to elevated plasma LDL-C levels, a major risk factor for cardiovascular disease.[1][3] Inhibition of the PCSK9-LDLR interaction is a clinically validated therapeutic strategy to lower LDL-C. Small molecule inhibitors like **Pcsk9-IN-10** offer a promising orally bioavailable alternative to monoclonal antibody therapies.

These application notes provide detailed protocols for the in vitro characterization of **Pcsk9-IN-10**, a small molecule inhibitor of the PCSK9-LDLR interaction. The described assays are fundamental for determining the potency and cellular activity of such inhibitors.

## Signaling Pathway and Mechanism of Action

PCSK9 is synthesized in the endoplasmic reticulum and secreted from hepatocytes.[2] Circulating PCSK9 binds to the epidermal growth factor-like repeat A (EGF-A) domain of the LDLR.[2][3] The PCSK9-LDLR complex is then internalized into the cell via endocytosis. Inside the acidic environment of the endosome, the binding affinity between PCSK9 and LDLR increases, preventing the receptor from recycling back to the cell surface and instead directing it towards the lysosome for degradation. By inhibiting the binding of PCSK9 to LDLR, **Pcsk9-IN-10** is expected to increase the recycling of LDLR to the hepatocyte surface, leading to enhanced clearance of LDL-C from the circulation.

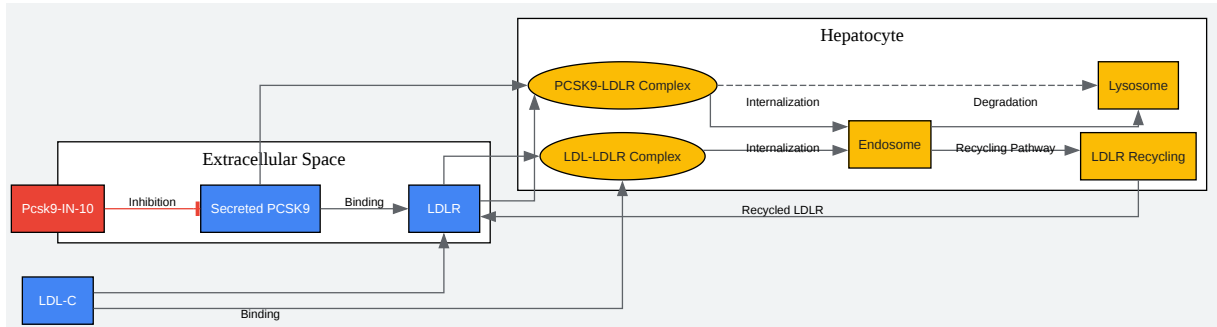

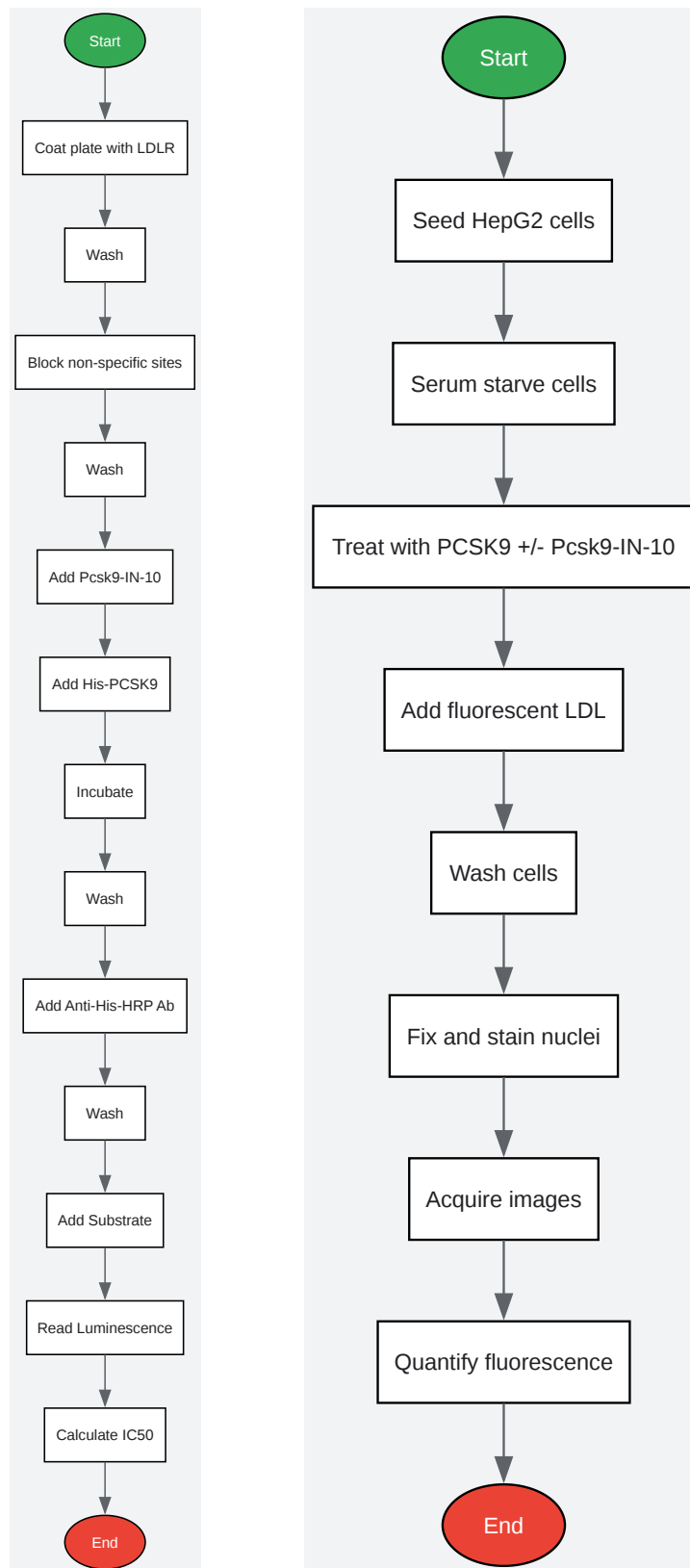

[Click to download full resolution via product page](#)

**Need Custom Synthesis?**

BenchChem offers custom synthesis for rare earth carbides and specific isotopic labeling.

Email: [info@benchchem.com](mailto:info@benchchem.com) or [Request Quote Online](#).

## References

- 1. Regulation of PCSK9 Expression and Function: Mechanisms and Therapeutic Implications - PMC [[pmc.ncbi.nlm.nih.gov](https://pubmed.ncbi.nlm.nih.gov/)]
- 2. Molecular and cellular function of the proprotein convertase subtilisin/kexin type 9 (PCSK9) - PMC [[pmc.ncbi.nlm.nih.gov](https://pubmed.ncbi.nlm.nih.gov/)]
- 3. PCSK9 function and physiology - PMC [[pmc.ncbi.nlm.nih.gov](https://pubmed.ncbi.nlm.nih.gov/)]
- To cite this document: BenchChem. [Application Notes and Protocols for In Vitro Evaluation of Pcsk9-IN-10]. BenchChem, [2026]. [Online PDF]. Available at: [<https://www.benchchem.com/product/b10855127/docs#application-notes-and-protocols-for-in-vitro-evaluation-of-pcsk9-in-10>]

---

**Disclaimer & Data Validity:**

The information provided in this document is for Research Use Only (RUO) and is strictly not intended for diagnostic or therapeutic procedures. While BenchChem strives to provide accurate protocols, we make no warranties, express or implied, regarding the fitness of this product for every specific experimental setup.

**Technical Support:** The protocols provided are for reference purposes. Unsure if this reagent suits your experiment?

**Need Industrial/Bulk Grade?** [Request Custom Synthesis Quote](#)

# BenchChem

Our mission is to be the trusted global source of essential and advanced chemicals, empowering scientists and researchers to drive progress in science and industry.

## Contact

Address: 3281 E Guasti Rd  
Ontario, CA 91761, United States  
Phone: (601) 213-4426  
Email: [info@benchchem.com](mailto:info@benchchem.com)

[Contact our Ph.D. Support Team for a compatibility check](#)