

avoiding non-specific binding of Wnt pathway activator 2

Author: BenchChem Technical Support Team. **Date:** December 2025

Compound of Interest

Compound Name: *Wnt pathway activator 2*

Cat. No.: *B10854544*

[Get Quote](#)

Technical Support Center: Wnt Pathway Activator 2

This technical support center provides troubleshooting guides and frequently asked questions (FAQs) to help researchers, scientists, and drug development professionals overcome challenges related to the use of **Wnt Pathway Activator 2**, with a specific focus on avoiding non-specific binding and ensuring targeted pathway activation.

Frequently Asked Questions (FAQs)

Q1: What is **Wnt Pathway Activator 2** and how does it work?

A1: **Wnt Pathway Activator 2** is a small molecule designed to stimulate the canonical Wnt/ β -catenin signaling pathway.^{[1][2][3]} It typically functions by targeting a component of the β -catenin destruction complex, such as Glycogen Synthase Kinase 3 β (GSK-3 β), leading to the stabilization and nuclear translocation of β -catenin.^{[4][5][6]} In the nucleus, β -catenin associates with TCF/LEF transcription factors to activate the expression of Wnt target genes.^{[5][7]}

Q2: What are the common causes of non-specific binding with **Wnt Pathway Activator 2**?

A2: Non-specific binding of small molecules like **Wnt Pathway Activator 2** can arise from several factors, including hydrophobic interactions, electrostatic or charge-based interactions

with cellular components other than the intended target, and binding to plasticware or other surfaces.[8][9][10] This can lead to off-target effects and inaccurate experimental results.[1][2]

Q3: How can I detect Wnt pathway activation in my experiments?

A3: Wnt pathway activation can be monitored through several methods. A widely used technique is the TOP/FOP-Flash reporter assay, which measures the transcriptional activity of the β -catenin/TCF complex.[11] Another common method is to detect the accumulation of β -catenin in the nucleus via immunofluorescence or western blotting of nuclear fractions.[11][12][13] Additionally, analyzing the expression of known Wnt target genes, such as Axin2 or Cyclin D1, through qPCR can confirm pathway activation.[5][11]

Q4: At what concentration should I use **Wnt Pathway Activator 2**?

A4: The optimal concentration of **Wnt Pathway Activator 2** depends on the cell type and experimental conditions. It is crucial to perform a dose-response curve to determine the effective concentration 50 (EC50) for Wnt pathway activation in your specific system. This will help in using the lowest effective concentration to minimize potential off-target effects.

Troubleshooting Guide: Non-Specific Binding

This guide provides solutions to common problems associated with non-specific binding of **Wnt Pathway Activator 2**.

Problem	Possible Cause	Recommended Solution
High background signal in reporter assays	Non-specific activation of the reporter construct or interaction of the activator with assay components.	<ol style="list-style-type: none">1. Run parallel experiments with a negative control (FOP-Flash) reporter.2. Reduce the concentration of the activator.3. Include appropriate vehicle controls (e.g., DMSO).
Observed cellular effects are inconsistent with Wnt pathway activation	The activator is hitting off-target pathways.	<ol style="list-style-type: none">1. Perform a dose-response experiment and use the lowest effective concentration.2. Validate target engagement with a rescue experiment using a known Wnt pathway inhibitor (e.g., a tankyrase inhibitor).3. Profile the expression of a panel of genes to check for activation of other signaling pathways.
Variability between replicate experiments	Non-specific binding to labware (e.g., pipette tips, microplates).	<ol style="list-style-type: none">1. Use low-retention plasticware.[14]2. Consider adding a low concentration of a non-ionic surfactant, such as Tween 20 (0.01-0.05%), to your media or buffers to reduce hydrophobic interactions.[8][9]
Cell toxicity or morphological changes at effective concentrations	Off-target effects due to non-specific binding to cellular proteins.	<ol style="list-style-type: none">1. Lower the concentration of Wnt Pathway Activator2. Reduce the treatment duration.3. Ensure the final concentration of the vehicle (e.g., DMSO) is not toxic to the cells.

Experimental Protocols

Protocol 1: Determining the Optimal Concentration of Wnt Pathway Activator 2

- Cell Seeding: Plate cells at a density that will result in 50-70% confluency at the time of the experiment.
- Activator Dilution Series: Prepare a serial dilution of **Wnt Pathway Activator 2** in your cell culture medium. A typical range to test would be from 1 nM to 10 μ M. Also, prepare a vehicle control (e.g., DMSO).
- Treatment: Replace the existing medium with the medium containing the different concentrations of the activator and the vehicle control.
- Incubation: Incubate the cells for a predetermined time (e.g., 24 hours).
- Readout: Measure Wnt pathway activation using a suitable method, such as a TOP-Flash reporter assay or qPCR for a Wnt target gene like AXIN2.
- Data Analysis: Plot the response as a function of the activator concentration and determine the EC50 value.

Protocol 2: Validating Specificity of Wnt Pathway Activation

- Co-treatment Setup: Treat cells with the determined EC50 concentration of **Wnt Pathway Activator 2** in the presence and absence of a known Wnt pathway inhibitor (e.g., IWR-1 or XAV-939). Include controls for the vehicle and the inhibitor alone.
- Incubation: Incubate for the standard duration of your experiment.
- Analysis: Assess Wnt pathway activation. A specific activation by **Wnt Pathway Activator 2** should be significantly reduced in the presence of the Wnt pathway inhibitor.

Protocol 3: Reducing Non-Specific Binding in Cellular Assays

- **Buffer Modification:** To mitigate non-specific binding due to charge interactions, consider adjusting the salt concentration of your buffer. Increasing the salt concentration (e.g., with NaCl) can shield charged interactions.[8][9][15]
- **Addition of Blocking Agents:** For experiments involving protein interactions, the addition of a blocking agent like Bovine Serum Albumin (BSA) at a low concentration (e.g., 0.1%) to your buffer can help prevent non-specific protein-protein interactions.[8][9][15]
- **Use of Surfactants:** To counter hydrophobic interactions, include a non-ionic surfactant like Tween 20 (0.01-0.05%) in your experimental buffers.[8][9][15] This can also help prevent the compound from sticking to plastic surfaces.[8][15]

Visualizing Key Concepts

Below are diagrams illustrating the Wnt signaling pathway and workflows for troubleshooting non-specific binding.

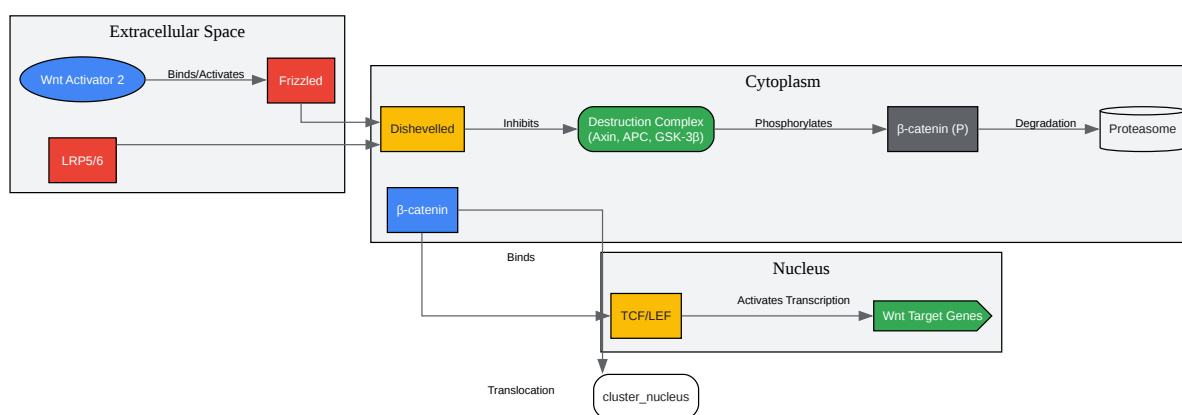

[Click to download full resolution via product page](#)

Caption: Canonical Wnt Signaling Pathway Activation.

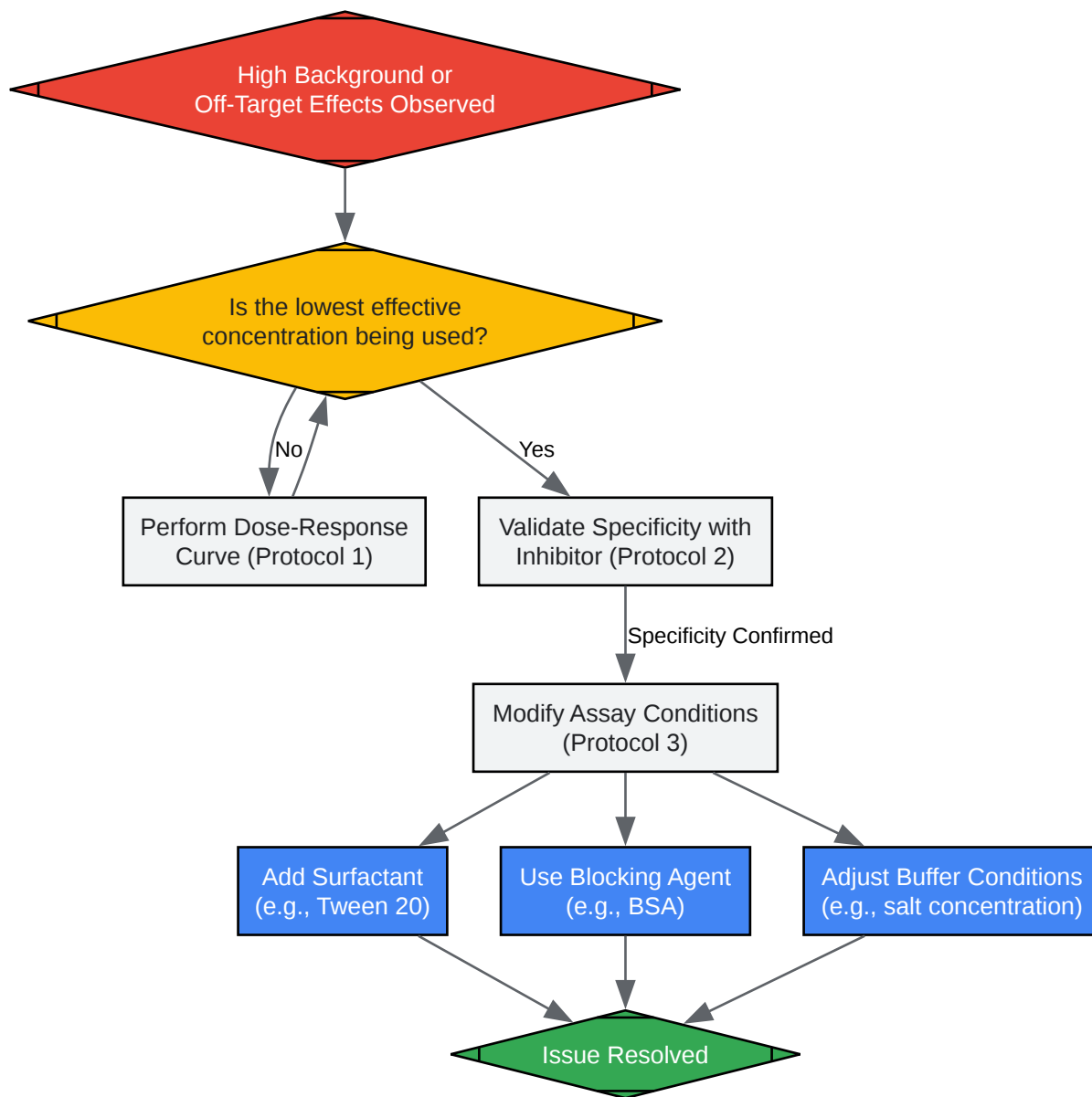

[Click to download full resolution via product page](#)

Caption: Troubleshooting Workflow for Non-Specific Binding.

Need Custom Synthesis?

BenchChem offers custom synthesis for rare earth carbides and specific isotopic labeling.

Email: info@benchchem.com or [Request Quote Online](#).

References

- 1. Wnt signaling activation: targets and therapeutic opportunities for stem cell therapy and regenerative medicine - PMC [pmc.ncbi.nlm.nih.gov]
- 2. Wnt signaling activation: targets and therapeutic opportunities for stem cell therapy and regenerative medicine. – CIRM [cirm.ca.gov]
- 3. scbt.com [scbt.com]
- 4. Can we safely target the WNT pathway? - PMC [pmc.ncbi.nlm.nih.gov]
- 5. Regulation of the Wnt signaling pathway by disabled-2 (Dab2) - PMC [pmc.ncbi.nlm.nih.gov]
- 6. origene.com [origene.com]
- 7. m.youtube.com [m.youtube.com]
- 8. nicoyalife.com [nicoyalife.com]
- 9. 4 Ways To Reduce Non-specific Binding in Surface Plasmon Resonance Experiments | Technology Networks [technologynetworks.com]
- 10. WO2008055080A2 - Method for blocking non-specific protein binding on a functionalized surface - Google Patents [patents.google.com]
- 11. How to detect and activate Wnt signaling | The WNT Homepage [wnt.stanford.edu]
- 12. researchgate.net [researchgate.net]
- 13. journals.biologists.com [journals.biologists.com]
- 14. Nonspecific Binding: Main Factors of Occurrence and Strategies - WuXi AppTec DMPK [dmpkservice.wuxiapptec.com]
- 15. How to eliminate non-specific binding? | AAT Bioquest [aatbio.com]
- To cite this document: BenchChem. [avoiding non-specific binding of Wnt pathway activator 2]. BenchChem, [2025]. [Online PDF]. Available at: [https://www.benchchem.com/product/b10854544#avoiding-non-specific-binding-of-wnt-pathway-activator-2]

Disclaimer & Data Validity:

The information provided in this document is for Research Use Only (RUO) and is strictly not intended for diagnostic or therapeutic procedures. While BenchChem strives to provide

accurate protocols, we make no warranties, express or implied, regarding the fitness of this product for every specific experimental setup.

Technical Support: The protocols provided are for reference purposes. Unsure if this reagent suits your experiment? [[Contact our Ph.D. Support Team for a compatibility check](#)]

Need Industrial/Bulk Grade? [Request Custom Synthesis Quote](#)

BenchChem

Our mission is to be the trusted global source of essential and advanced chemicals, empowering scientists and researchers to drive progress in science and industry.

Contact

Address: 3281 E Guasti Rd

Ontario, CA 91761, United States

Phone: (601) 213-4426

Email: info@benchchem.com