

Technical Support Center: CCNDBP1 siRNA Experiments

Author: BenchChem Technical Support Team. **Date:** April 2026

Compound of Interest

Compound Name: CCNDBP1 Human Pre-designed
siRNA Set A

Cat. No.: B10854636

[Get Quote](#)

This guide provides troubleshooting and frequently asked questions (FAQs) for researchers experiencing issues with pre-designed small interfering RNA (siRNA) targeting Cyclin D1 Binding Protein 1 (CCNDBP1).

Troubleshooting Guide: Low or No CCNDBP1 Knockdown

If you are observing suboptimal or no reduction in CCNDBP1 expression, systematically evaluate the following potential causes.

Question: My pre-designed siRNA for CCNDBP1 is not reducing mRNA or protein levels. What should I check first?

Answer: The most critical first step is to verify your experimental setup using appropriate controls. Without controls, it's impossible to determine the source of the problem.

Essential Controls for Every siRNA Experiment:

- **Positive Control siRNA:** Use a validated siRNA known to effectively knock down a housekeeping gene (e.g., GAPDH, Cyclophilin B).[1][2][3][4] This confirms that your transfection reagent and overall workflow are capable of delivering siRNA and inducing knockdown in your specific cell line.[1][3] A successful positive control should yield >70-80% knockdown of its target.[4][5][6]
- **Negative Control siRNA:** Use a non-targeting or scrambled siRNA sequence that has no known target in your cell model.[1][3][6] This control is crucial for distinguishing sequence-specific knockdown from non-specific effects caused by the transfection process itself.[1][4]
- **Untreated Control:** This sample consists of cells that have not been exposed to siRNA or transfection reagent. It establishes the baseline (normal) expression level of CCNDBP1.[3][4][7]
- **Mock-Transfected Control:** This sample includes cells treated only with the transfection reagent (without any siRNA).[3][7] It helps identify any cellular toxicity or non-specific effects caused by the delivery agent.[3]

If your positive control siRNA works effectively but the CCNDBP1 siRNA does not, the issue likely lies with the siRNA itself or the target gene's characteristics. If the positive control also fails, the problem is likely with the transfection protocol or cell conditions.[8]

Question: My positive control worked, but the CCNDBP1 siRNA still shows no effect. What's the next step?

Answer: If delivery is successful, the issue may be related to the specifics of your transfection protocol for this particular target or the analysis method. Optimization is key.[9][10]

Key Optimization Parameters:

- **siRNA Concentration:** The optimal siRNA concentration can vary. Too little may result in poor knockdown, while too much can cause toxicity and off-target effects.[10][11] Start with a concentration range of 1-30 nM, with 10 nM being a common starting point.[10]
- **Cell Density:** Cells should be healthy and actively dividing, typically at 70-80% confluency at the time of transfection.[7] Both too low and too high cell densities can negatively impact transfection efficiency.[5][12]

- **Transfection Reagent Volume:** The ratio of transfection reagent to siRNA is critical and must be optimized for each cell type.[11]
- **Incubation Time:** Assess knockdown at multiple time points. mRNA levels are typically measured 24-48 hours post-transfection, while protein levels are checked at 48-96 hours, depending on the protein's half-life.[5]

Parameter	Starting Point	Optimization Range	Key Consideration
siRNA Concentration	10 nM	1 - 30 nM	Balance knockdown efficiency with cell viability to avoid off-target effects.[10][13]
Cell Density at Transfection	70% Confluency	50 - 80% Confluency	Ensure cells are in an optimal physiological state for uptake.[7]
Time for mRNA Analysis	24 hours	24 - 48 hours	mRNA degradation is an early event in the RNAi pathway.[5]
Time for Protein Analysis	48 hours	48 - 96 hours	Dependent on the half-life and turnover rate of the CCNDBP1 protein.[5][8]

Question: I've optimized the protocol, but knockdown is still weak. Could there be an issue with the CCNDBP1 gene or the siRNA design?

Answer: Yes, this is possible. Not all siRNA sequences are equally effective.[14][15]

Potential Issues and Solutions:

- **Ineffective siRNA Sequence:** Even pre-designed siRNAs can have variable efficacy. It is recommended to test 2-4 different siRNA sequences targeting different regions of the CCNDBP1 mRNA to find the most effective one.[9]

- **Alternative Splicing:** If the siRNA targets an exon that is not present in all transcript variants of CCNDBP1, the knockdown effect will be incomplete. Check databases like Ensembl or UCSC Genome Browser for known splice variants.
- **Low Target Expression:** If CCNDBP1 is expressed at very low levels in your cell line, detecting a further reduction can be technically challenging.[\[14\]](#) Confirm baseline expression via RT-qPCR before starting knockdown experiments.
- **RNA Stability and Structure:** The secondary structure of the CCNDBP1 mRNA could make the target site inaccessible to the RISC complex. Using a pool of multiple siRNAs targeting the same gene can sometimes overcome this.[\[16\]](#)

Frequently Asked Questions (FAQs)

Q1: How do I properly validate the knockdown of CCNDBP1? A1: Validation should always be performed at both the mRNA and protein levels.[\[5\]](#)[\[17\]](#)

- **mRNA Level:** Use quantitative reverse transcription PCR (qRT-PCR) to measure the reduction in CCNDBP1 transcripts.[\[17\]](#) This is the most direct way to assess siRNA activity.[\[18\]](#)
- **Protein Level:** Use Western blotting to confirm a decrease in CCNDBP1 protein.[\[17\]](#) This is crucial as it demonstrates a functional consequence of the mRNA knockdown.[\[17\]](#)[\[19\]](#)

Q2: My cells are dying after transfection. What can I do? A2: Cell death is often due to toxicity from the transfection reagent or high concentrations of siRNA.[\[8\]](#)

- Run a mock transfection (reagent only) to see if the reagent itself is toxic to your cells.[\[8\]](#)
- Reduce the concentration of both the siRNA and the transfection reagent.
- Ensure you are not using antibiotics in the media during transfection, as this can increase cell death.[\[5\]](#)[\[9\]](#)
- Optimize cell density; unhealthy or overly confluent cells are more sensitive to transfection-induced stress.[\[5\]](#)

Q3: What are off-target effects and how can I minimize them? A3: Off-target effects occur when your siRNA unintentionally silences genes other than CCNDBP1, often due to partial sequence homology.[\[11\]](#)[\[16\]](#)[\[20\]](#)

- Use the lowest effective siRNA concentration: Off-target effects are often dose-dependent. [\[13\]](#)
- Use modified siRNAs: Some vendors offer chemically modified siRNAs that reduce off-target binding.[\[16\]](#)[\[20\]](#)[\[21\]](#)
- Test multiple siRNAs: Using two or more different siRNAs that target CCNDBP1 and produce the same phenotype provides strong evidence that the effect is on-target.[\[7\]](#)
- Perform rescue experiments: If possible, re-introduce a version of the CCNDBP1 gene that is resistant to your siRNA. Restoring the phenotype confirms the specificity of the knockdown.

Q4: Does the presence of serum in the culture media affect transfection? A4: Yes, it can. Many transfection reagents require complex formation between the siRNA and the reagent to occur in a serum-free medium.[\[9\]](#)[\[12\]](#) However, after the complexes are formed, they can often be added to cells growing in their normal, serum-containing medium. Always follow the specific instructions for your transfection reagent.[\[12\]](#)

Experimental Protocols

Protocol 1: Transfection Efficiency Assessment with a Fluorescently Labeled Control siRNA

This protocol verifies the efficiency of siRNA delivery into your cells, a critical first step in troubleshooting.

- Cell Seeding: Seed your cells in a multi-well plate (e.g., 24-well) at a density that will result in 70-80% confluency the next day.
- Complex Formation:

- In tube A, dilute a fluorescently labeled negative control siRNA (e.g., with FAM or CY3) to the desired final concentration in serum-free media.
- In tube B, dilute your transfection reagent (e.g., Lipofectamine RNAiMAX) in serum-free media according to the manufacturer's protocol.
- Combine the contents of tube A and tube B, mix gently, and incubate at room temperature for 10-20 minutes to allow complexes to form.
- Transfection: Add the siRNA-lipid complexes drop-wise to the cells in each well.
- Incubation: Incubate the cells for 24-48 hours under normal growth conditions.
- Analysis: Visualize the cells using a fluorescence microscope. Calculate transfection efficiency by counting the number of fluorescent cells relative to the total number of cells (viewed under brightfield). A high percentage (>80%) of fluorescent cells indicates successful delivery.

Protocol 2: Validation of CCNDBP1 Knockdown by qRT-PCR

This protocol quantifies the reduction of CCNDBP1 mRNA.

- Transfection: Transfect cells with CCNDBP1 siRNA, a positive control siRNA (e.g., GAPDH), and a negative control siRNA in parallel as described above. Also include an untreated control group.
- Incubation: Incubate for 24-48 hours.
- RNA Isolation: Harvest the cells and isolate total RNA using a standard kit (e.g., TRIzol or a column-based method). Ensure RNA quality is high (A260/280 ratio ~2.0).
- cDNA Synthesis: Synthesize complementary DNA (cDNA) from 1 µg of total RNA using a reverse transcription kit.
- qPCR:
 - Set up qPCR reactions using a SYBR Green or TaqMan-based master mix.

- Include primers for your target gene (CCNDBP1) and a stable housekeeping gene (e.g., GAPDH, ACTB) for normalization.
- Run the reactions on a real-time PCR machine.
- Data Analysis: Calculate the relative expression of CCNDBP1 using the $\Delta\Delta C_t$ method.[17] Compare the normalized expression in cells treated with CCNDBP1 siRNA to those treated with the negative control siRNA. A significant reduction indicates successful mRNA knockdown.

Visual Guides

CCNDBP1 Signaling Pathway

CCNDBP1 (also known as GCIP) is implicated in cell cycle regulation and DNA damage response. It can interact with Cyclin D1, inhibiting the Cyclin D1/CDK4 complex and thus preventing the phosphorylation of the Retinoblastoma (Rb) protein. This action helps to block E2F-mediated transcription, which negatively regulates cell cycle progression.[22] More recent studies show CCNDBP1 can also activate the ATM-CHK2 pathway in response to DNA damage by inhibiting EZH2, contributing to cell survival and chemoresistance.[23]

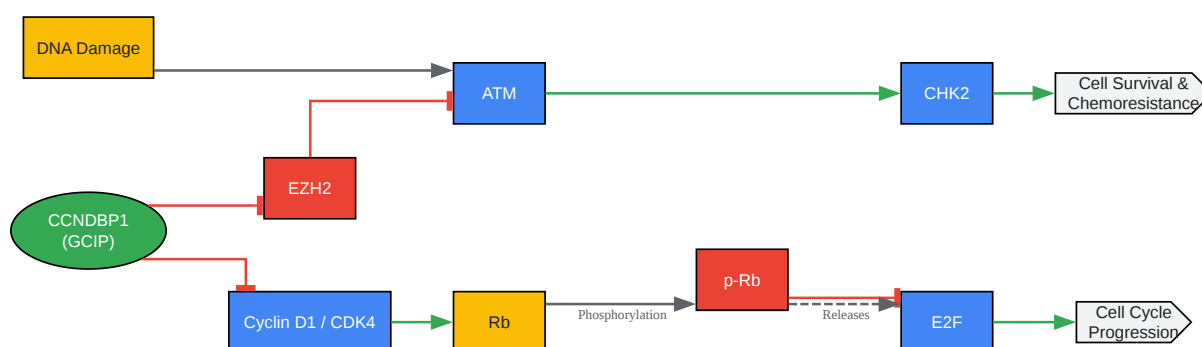

[Click to download full resolution via product page](#)

Caption: Simplified signaling pathways involving CCNDBP1 in cell cycle control and DNA damage response.

siRNA Troubleshooting Workflow

This flowchart provides a logical sequence of steps to diagnose why your CCNDBP1 siRNA experiment may be failing.

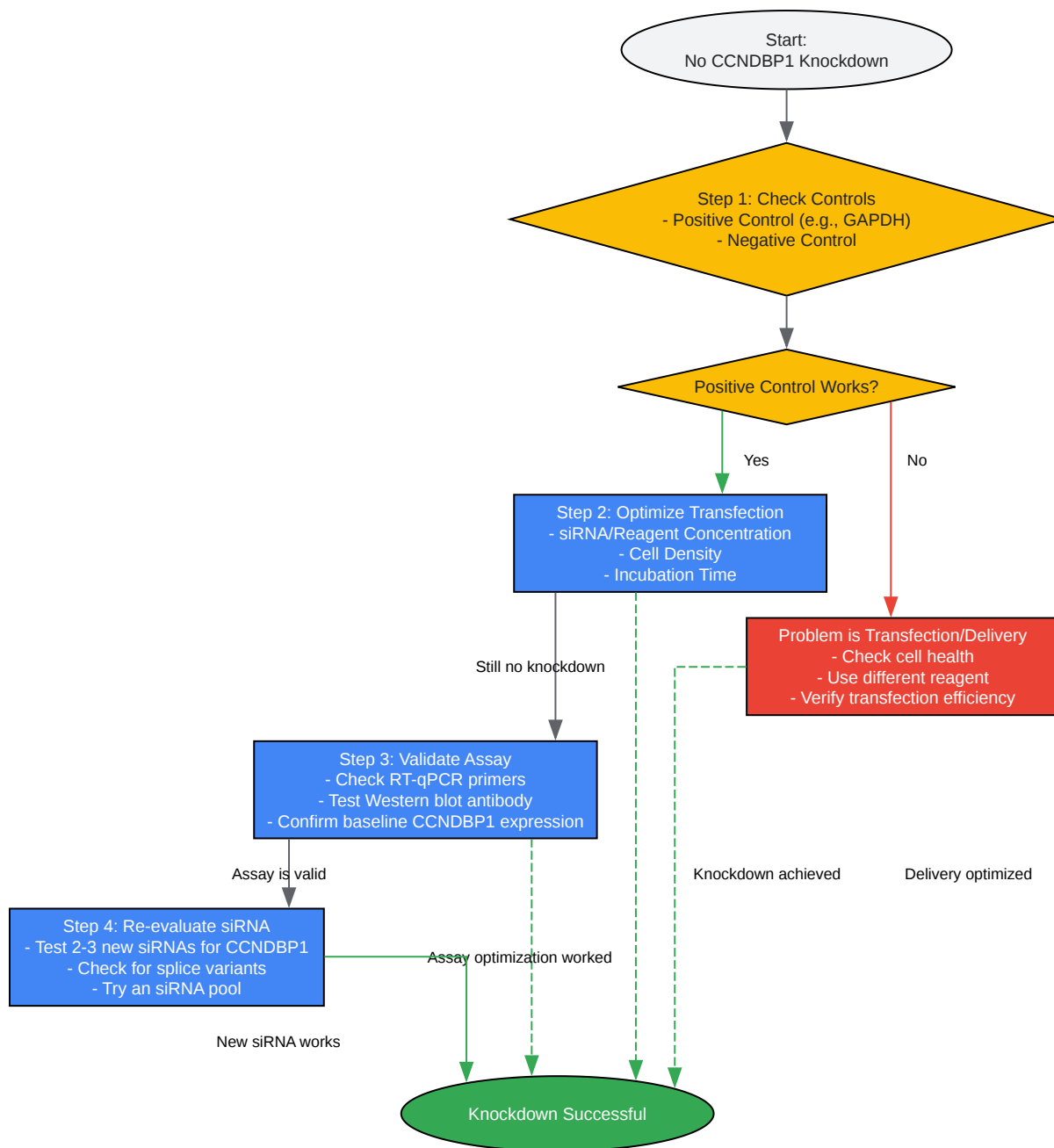

[Click to download full resolution via product page](#)

Caption: A step-by-step workflow for troubleshooting failed CCNDBP1 siRNA knockdown experiments.

Need Custom Synthesis?

BenchChem offers custom synthesis for rare earth carbides and specific isotopic labeling.

Email: info@benchchem.com or [Request Quote Online](#).

References

- [1. What are the most important controls for my siRNA experiment? \[horizondiscovery.com\]](#)
- [2. Positive and Negative control siRNA's for your experiments. >90% siRNA knockdown for positive controls \[us.bioneer.com\]](#)
- [3. Performing appropriate RNAi control experiments \[qiagen.com\]](#)
- [4. horizondiscovery.com \[horizondiscovery.com\]](#)
- [5. Top Ten Ways to Optimize siRNA Delivery in Cultured Cells | Thermo Fisher Scientific - TW \[thermofisher.com\]](#)
- [6. Controls for RNAi Experiments | Thermo Fisher Scientific - TW \[thermofisher.com\]](#)
- [7. 10 tips on how to best optimize siRNA transfection | Proteintech Group \[ptglab.com\]](#)
- [8. RNAi Synthetics Support—Troubleshooting | Thermo Fisher Scientific - HK \[thermofisher.com\]](#)
- [9. Optimizing siRNA Transfection | Thermo Fisher Scientific - SG \[thermofisher.com\]](#)
- [10. Optimizing siRNA Transfection for RNAi | Thermo Fisher Scientific - HK \[thermofisher.com\]](#)
- [11. Guidelines for transfection of siRNA \[qiagen.com\]](#)
- [12. Guidelines for RNA Transfection | Thermo Fisher Scientific - US \[thermofisher.com\]](#)
- [13. siRNA Off-Target Effects Can Be Reduced at Concentrations That Match Their Individual Potency | PLOS One \[journals.plos.org\]](#)
- [14. researchgate.net \[researchgate.net\]](#)
- [15. Why isn't my shRNA knocking down my gene of interest? | VectorBuilder \[en.vectorbuilder.com\]](#)
- [16. Methods for reducing siRNA off-target binding | Eclipsebio \[eclipsebio.com\]](#)

- [17. Quantitation siRNA-induced Knockdown by qRT-PCR and WB - RNA Transfection Reagents \[rnatransfection.com\]](#)
- [18. Top three tips for troubleshooting your RNAi experiment \[horizondiscovery.com\]](#)
- [19. researchgate.net \[researchgate.net\]](#)
- [20. horizondiscovery.com \[horizondiscovery.com\]](#)
- [21. news-medical.net \[news-medical.net\]](#)
- [22. CCNDBP1, a Prognostic Marker Regulated by DNA Methylation, Inhibits Aggressive Behavior in Dedifferentiated Liposarcoma via Repressing Epithelial Mesenchymal Transition - PMC \[pmc.ncbi.nlm.nih.gov\]](#)
- [23. mdpi.com \[mdpi.com\]](#)
- To cite this document: BenchChem. [Technical Support Center: CCNDBP1 siRNA Experiments]. BenchChem, [2026]. [Online PDF]. Available at: [\[https://www.benchchem.com/product/b10854636/docs#technical-support-center-ccndbp1-sirna-experiments\]](https://www.benchchem.com/product/b10854636/docs#technical-support-center-ccndbp1-sirna-experiments)

Disclaimer & Data Validity:

The information provided in this document is for Research Use Only (RUO) and is strictly not intended for diagnostic or therapeutic procedures. While BenchChem strives to provide accurate protocols, we make no warranties, express or implied, regarding the fitness of this product for every specific experimental setup.

Technical Support: The protocols provided are for reference purposes. Unsure if this reagent suits your experiment?

Need Industrial/Bulk Grade? [Request Custom Synthesis Quote](#)

BenchChem

Our mission is to be the trusted global source of essential and advanced chemicals, empowering scientists and researchers to drive progress in science and industry.

Contact

Address: 3281 E Guasti Rd
Ontario, CA 91761, United States
Phone: (601) 213-4426
Email: info@benchchem.com

Contact our Ph.D. Support Team for a compatibility check