

# Overcoming experimental variability in ADRA1D functional assays

**Author:** BenchChem Technical Support Team. **Date:** April 2026

## Compound of Interest

Compound Name: ADRA1D receptor antagonist 1

Cat. No.: B10854546

[Get Quote](#)

## ADRA1D Functional Assays: Technical Support Center

This guide provides troubleshooting advice and detailed protocols to help researchers, scientists, and drug development professionals overcome experimental variability in functional assays for the Alpha-1D Adrenergic Receptor (ADRA1D).

### Frequently Asked Questions (FAQs)

Q1: What is the primary signaling pathway for ADRA1D and which assays are most suitable?

A1: The ADRA1D receptor is a G-protein-coupled receptor (GPCR) that primarily signals through the Gq/11 family of G-proteins.[1][2][3][4][5] Upon agonist binding, the Gq protein activates Phospholipase C (PLC), which cleaves phosphatidylinositol 4,5-bisphosphate (PIP2) into inositol trisphosphate (IP3) and diacylglycerol (DAG). IP3 triggers the release of calcium (Ca<sup>2+</sup>) from intracellular stores.[6][7] Therefore, the most suitable functional assays are those that measure downstream events in this cascade, such as intracellular calcium mobilization or the accumulation of IP3 metabolites.[6][8]

Q2: My signal-to-background ratio is low. What are the common causes?

A2: A low signal-to-background ratio can stem from several factors:

- **Suboptimal Cell Density:** Too few cells will not produce a detectable signal, while too many can lead to high background and a decreased assay window.[9][10][11]
- **Low Receptor Expression:** The cell line may not express sufficient ADRA1D receptors. Verify expression using a validated method (e.g., qPCR, western blot, or a binding assay).
- **Inactive Agonist:** Ensure the agonist is potent, correctly prepared, and has not degraded.
- **Incorrect Assay Conditions:** Factors like stimulation time, buffer composition, and temperature can significantly impact results.[9][12]
- **Cell Health:** Only use healthy, viable cells that are within a low passage number to ensure consistent physiological responses.[10][13]

Q3: How important is cell density and how do I optimize it?

A3: Cell density is a critical parameter. The optimal density ensures a robust signal without being so high that it causes cell stress or ligand depletion.[9][10][14] To optimize, perform a matrix experiment testing a range of cell seeding densities against a full agonist concentration-response curve.[9] Choose the cell density that provides the largest and most consistent assay window (the ratio of the maximum signal to the basal signal).

Q4: Should I serum-starve my cells before the assay?

A4: Serum starvation can synchronize cells in the same cell cycle phase (typically G0/G1), which can reduce variability.[15] However, prolonged starvation (e.g., more than 24 hours) can induce cellular stress and inhibit protein synthesis, negatively affecting the assay.[16] If starvation is necessary, an overnight period is common. Alternatively, consider using a medium with reduced serum (e.g., 1%) instead of complete starvation to maintain cell health.[16]

## Signaling Pathway and Workflow Diagrams

The following diagrams illustrate the key pathways and processes involved in ADRA1D functional assays.

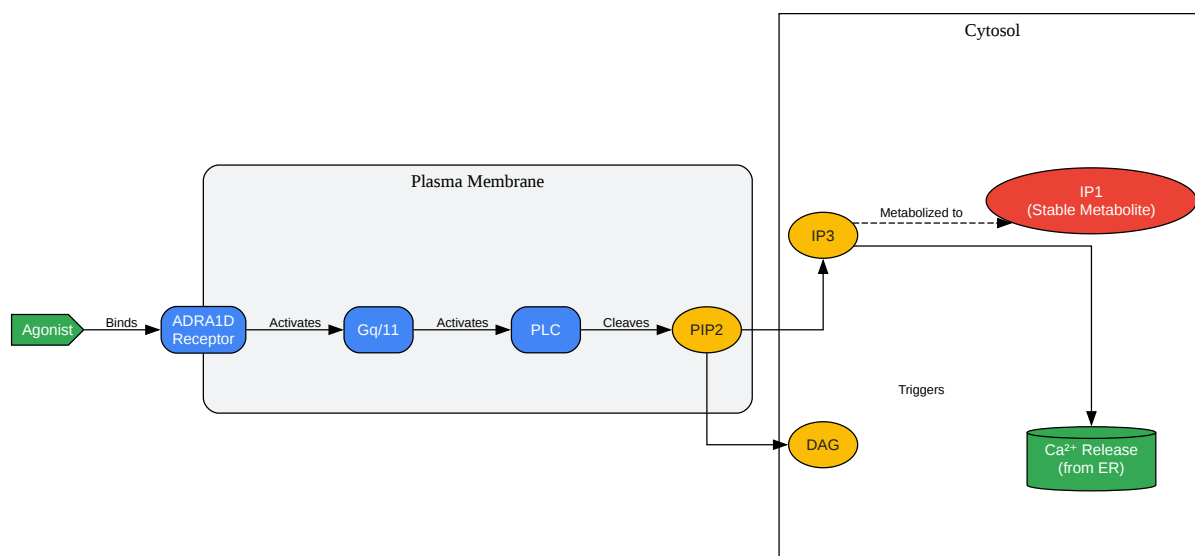

[Click to download full resolution via product page](#)

**Caption:** ADRA1D Gq signaling cascade.

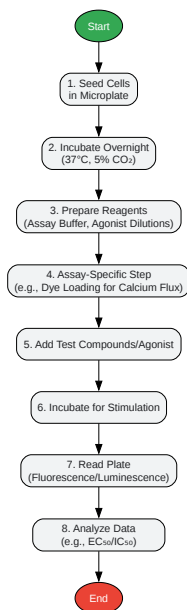

[Click to download full resolution via product page](#)

**Caption:** General workflow for a cell-based functional assay.

## Troubleshooting Guide

This section provides a structured approach to diagnosing and solving common experimental issues.

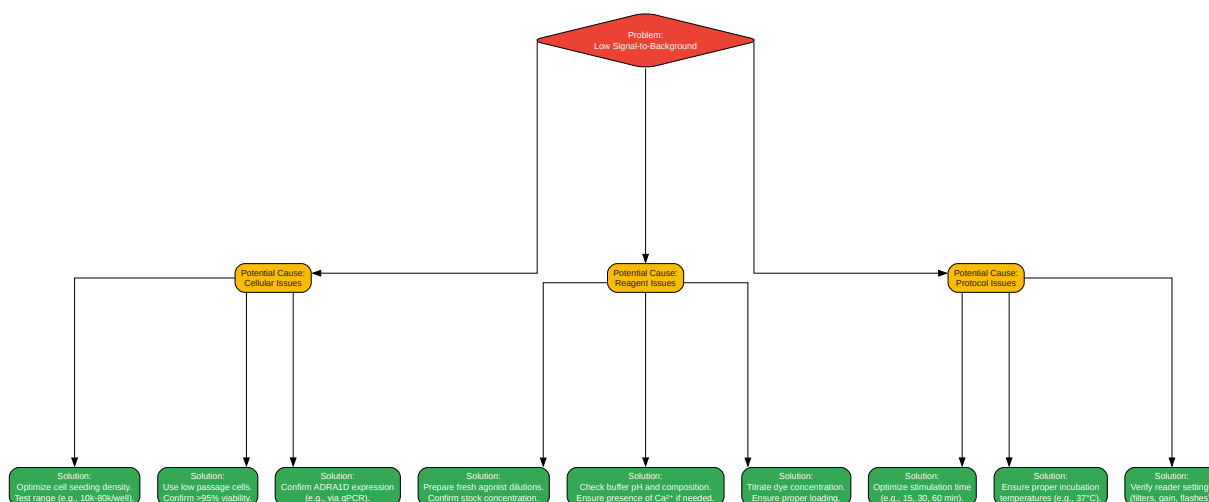

[Click to download full resolution via product page](#)

**Caption:** Troubleshooting decision tree for low signal issues.

## Quantitative Troubleshooting Reference

Problem	Potential Cause	Recommended Solution & Key Parameters
High Well-to-Well Variability	Inconsistent cell seeding	Ensure a homogenous cell suspension before and during plating. Use reverse pipetting techniques.
Edge effects in the microplate	Avoid using the outer wells of the plate or fill them with sterile buffer/media to maintain humidity.	
Low Signal Window	Suboptimal cell density	Test a range of densities. For 96-well plates, start with 40,000–80,000 cells/well; for 384-well, 10,000–20,000 cells/well.
Inappropriate stimulation time	Perform a time-course experiment (e.g., 5 min to 2 hours) to find the peak signal time. <a href="#">[9]</a>	
No Response to Agonist	Poor receptor-G protein coupling	Consider co-transfection with a promiscuous or chimeric G-protein (e.g., Gα15/16) to force coupling to the PLC pathway. <a href="#">[17]</a>
Agonist degradation	Prepare fresh agonist dilutions for each experiment from a validated frozen stock.	
High Background Signal	Autofluorescence of compounds	Measure the fluorescence of compounds in cell-free buffer to identify interference.
Basal receptor activity	May be inherent to the cell line. If problematic, consider	

using an inverse agonist to reduce background.

---

Dye overloading (Calcium assays)

Titrate the fluorescent dye concentration to find the lowest level that gives a robust signal without high background.[12]

---

## Experimental Protocols

### Protocol 1: Calcium Flux Assay (Fluo-8 Dye)

This protocol measures the change in intracellular calcium following receptor activation.

Materials:

- ADRA1D-expressing cells (e.g., HEK293, CHO)
- Black, clear-bottom 96-well or 384-well tissue culture plates
- Fluo-8 No Wash Calcium Assay Kit
- Hanks' Balanced Salt Solution with 20 mM HEPES (HHBS)
- ADRA1D agonist (e.g., Phenylephrine, Norepinephrine)
- Fluorescence microplate reader (e.g., FLIPR, FlexStation) with filters for Ex/Em = 490/525 nm.

Methodology:

- Cell Plating:
  - Plate adherent cells in a black, clear-bottom microplate at a pre-optimized density (e.g., 50,000 cells/100  $\mu$ L/well for a 96-well plate) and incubate overnight.
- Dye Loading Solution Preparation:

- Prepare the Fluo-8 dye-loading solution according to the manufacturer's protocol, typically by mixing the dye concentrate and a buffer additive into HHBS.
- Cell Loading:
  - Remove the cell culture medium from the plate.
  - Add 100  $\mu$ L (for 96-well) of Fluo-8 dye-loading solution to each well.
  - Incubate at 37°C for 30 minutes, followed by 30 minutes at room temperature, protected from light.
- Agonist Preparation:
  - Prepare a 2X concentration series of the agonist in HHBS.
- Assay Measurement:
  - Place the cell plate into the fluorescence reader.
  - Set the reader to record a baseline fluorescence for 10-20 seconds.
  - Program the instrument to add 100  $\mu$ L of the 2X agonist solution to the wells.
  - Immediately begin reading fluorescence intensity at 490/525 nm every 1-2 seconds for a total of 2-3 minutes.
- Data Analysis:
  - Calculate the response as the difference between the peak fluorescence after agonist addition and the average baseline fluorescence.
  - Plot the response against the log of the agonist concentration and fit to a four-parameter logistic equation to determine EC<sub>50</sub>.

## Protocol 2: IP1 Accumulation Assay (HTRF)

This protocol provides a robust, endpoint measurement of Gq activation by quantifying the stable IP3 metabolite, IP1.[\[6\]](#)[\[18\]](#)

#### Materials:

- ADRA1D-expressing cells
- White, solid-bottom 384-well microplate
- IP-One HTRF Assay Kit (contains IP1-d2 conjugate, anti-IP1 Cryptate antibody, and stimulation buffer with LiCl)[6][7]
- ADRA1D agonist
- HTRF-compatible microplate reader.[7]

#### Methodology:

- Cell Plating:
  - Resuspend cells in their culture medium and dispense into a white 384-well plate at a pre-optimized density (e.g., 15,000 cells/5  $\mu$ L/well).[19]
  - Allow cells to adhere and recover for at least 24 hours.
- Cell Stimulation:
  - Prepare agonist dilutions in the provided stimulation buffer (containing LiCl, which prevents IP1 degradation).[13][18]
  - Add 2.5  $\mu$ L of the agonist solution to the cells.[19]
  - Incubate the plate at 37°C for a pre-optimized time, typically 60 minutes.[6][7][19]
- IP1 Detection:
  - Add 5  $\mu$ L of the IP1-d2 conjugate to each well.
  - Add 5  $\mu$ L of the anti-IP1 Cryptate antibody to each well.
  - Incubate at room temperature for 60 minutes, protected from light.[19]

- Assay Measurement:
  - Read the plate on an HTRF-compatible reader, measuring emission at both 665 nm (acceptor) and 620 nm (donor).[7][13]
- Data Analysis:
  - Calculate the 665/620 emission ratio for each well. The HTRF signal is inversely proportional to the amount of IP1 produced.[19]
  - Convert the ratio to IP1 concentration using a standard curve run in parallel.
  - Plot the IP1 concentration against the log of the agonist concentration to determine EC<sub>50</sub>.

### Need Custom Synthesis?

BenchChem offers custom synthesis for rare earth carbides and specific isotopic labeling.

Email: [info@benchchem.com](mailto:info@benchchem.com) or [Request Quote Online](#).

## References

1. [genecards.org](https://www.genecards.org) [genecards.org]
2. [Alpha-1D adrenergic receptor - Wikipedia](https://en.wikipedia.org/wiki/Alpha-1D_adrenergic_receptor) [en.wikipedia.org]
3. [ADRA1D adrenoceptor alpha 1D \[Homo sapiens \(human\)\] - Gene - NCBI](https://www.ncbi.nlm.nih.gov/gene/6424) [ncbi.nlm.nih.gov]
4. [ADRA1D adrenoceptor alpha 1D \[Homo sapiens \(human\)\] - Gene - NCBI](https://www.ncbi.nlm.nih.gov/gene/6424) [ncbi.nlm.nih.gov]
5. [ADRA1D adrenoceptor alpha 1D - NIH Genetic Testing Registry \(GTR\) - NCBI](https://www.ncbi.nlm.nih.gov/gtr/genes/6424) [ncbi.nlm.nih.gov]
6. [HTRF IP-One Gq Detection Kit-WEICHLAB](https://www.weichilab.com) [weichilab.com]
7. [bmglabtech.com](https://www.bmglabtech.com) [bmglabtech.com]
8. [apac.eurofinsdiscovery.com](https://www.apac.eurofinsdiscovery.com) [apac.eurofinsdiscovery.com]
9. [revvity.com](https://www.revivity.com) [revvity.com]
10. [biocompare.com](https://www.biocompare.com) [biocompare.com]

- [11. promegaconnections.com \[promegaconnections.com\]](https://promegaconnections.com)
- [12. Intracellular Calcium Flux - University of Utah Flow Cytometry \[flowcytometry.cores.utah.edu\]](https://flowcytometry.cores.utah.edu)
- [13. IP-3/IP-1 Assays - Assay Guidance Manual - NCBI Bookshelf \[ncbi.nlm.nih.gov\]](https://ncbi.nlm.nih.gov)
- [14. researchgate.net \[researchgate.net\]](https://researchgate.net)
- [15. researchgate.net \[researchgate.net\]](https://researchgate.net)
- [16. researchgate.net \[researchgate.net\]](https://researchgate.net)
- [17. sbdrugdiscovery.com \[sbdrugdiscovery.com\]](https://sbdrugdiscovery.com)
- [18. HTRF IP-One Gq assay on SpectraMax Readers \[moleculardevices.com\]](https://moleculardevices.com)
- [19. bmglabtech.com \[bmglabtech.com\]](https://bmglabtech.com)
- To cite this document: BenchChem. [Overcoming experimental variability in ADRA1D functional assays]. BenchChem, [2026]. [Online PDF]. Available at: [\[https://www.benchchem.com/product/b10854546/docs#overcoming-experimental-variability-in-adra1d-functional-assays\]](https://www.benchchem.com/product/b10854546/docs#overcoming-experimental-variability-in-adra1d-functional-assays)

---

#### Disclaimer & Data Validity:

The information provided in this document is for Research Use Only (RUO) and is strictly not intended for diagnostic or therapeutic procedures. While BenchChem strives to provide accurate protocols, we make no warranties, express or implied, regarding the fitness of this product for every specific experimental setup.

**Technical Support:** The protocols provided are for reference purposes. Unsure if this reagent suits your experiment?

**Need Industrial/Bulk Grade?** [Request Custom Synthesis Quote](#)

# BenchChem

Our mission is to be the trusted global source of essential and advanced chemicals, empowering scientists and researchers to drive progress in science and industry.

## Contact

Address: 3281 E Guasti Rd

Ontario, CA 91761, United States

Phone: (601) 213-4426

Email: [info@benchchem.com](mailto:info@benchchem.com)

[Contact our Ph.D. Support Team for a compatibility check](#)