

Validating Arginine Vasopressin Function: A Comparative Guide to Knockout Mouse Models

Author: BenchChem Technical Support Team. **Date:** May 2026

Compound of Interest

Compound Name: *Arginine vasopressin*

Cat. No.: *B10846794*

[Get Quote](#)

For researchers, scientists, and drug development professionals, understanding the multifaceted roles of arginine vasopressin (AVP) is crucial for advancements in neuroscience, endocrinology, and pharmacology. Knockout mouse models have proven to be invaluable tools in dissecting the physiological and behavioral functions of AVP and its receptors. This guide provides a comprehensive comparison of various AVP-related knockout mouse models, supported by experimental data, detailed protocols, and visual representations of key biological pathways and experimental workflows.

Comparison of Key Knockout Mouse Models

The study of arginine vasopressin's diverse functions, from social behavior to water homeostasis, has been significantly advanced by the development of knockout mouse models targeting the AVP peptide itself or its specific receptors: V1a, V1b, and V2. Each model presents a unique phenotype, offering specific insights into the AVP system.

Arginine Vasopressin (AVP) Knockout Models

Constitutive knockout of the AVP gene often leads to neonatal lethality, making long-term studies challenging. To circumvent this, inducible knockout models have been developed.

Inducible AVP Knockout Mice: These models, often utilizing the Cre-LoxP system with a tamoxifen-inducible Cre recombinase, allow for the temporal control of AVP gene deletion.[1][2] This approach avoids developmental complications and allows for the study of AVP deficiency in adult mice. Upon induction with tamoxifen, these mice exhibit a profound decrease in urine osmolality, a classic sign of AVP deficiency, mirroring conditions like diabetes insipidus.[1][3][4]

Vasopressin Receptor Knockout Models

V1a Receptor Knockout (V1aRKO) Mice: The V1a receptor is primarily associated with social behaviors and blood pressure regulation. V1aRKO mice consistently display a profound impairment in social recognition.[5] They also exhibit a reduction in anxiety-like behaviors.[5][6] Interestingly, the role of V1aR in aggression appears to be species-dependent, with some studies in mice showing normal aggression, while others in different species report alterations.[7]

V1b Receptor Knockout (V1bRKO) Mice: The V1b receptor is implicated in the regulation of the hypothalamic-pituitary-adrenal (HPA) axis, stress responses, and aggression. V1bRKO mice show a marked reduction in aggressive behavior and modest impairments in social recognition.[3][8] These mice do not typically show global deficits in sensorimotor function, suggesting a more specific role for the V1bR in modulating social behaviors.[3]

V2 Receptor and Associated Knockout Models: The V2 receptor, predominantly found in the kidney, is the primary mediator of AVP's antidiuretic effects. While direct V2 receptor knockout mice are less common in behavioral studies, models targeting downstream effectors like Aquaporin-2 (AQP2) provide critical insights into AVP's role in water balance. Conditional knockout of AQP2 in the collecting ducts of the kidney results in a severe urinary concentrating defect, highlighting its essential role in AVP-mediated water reabsorption.

Quantitative Data Summary

The following tables summarize key quantitative data from studies characterizing these knockout mouse models.

Model	Parameter	Wild-Type (WT)	Knockout (KO)	Reference
Inducible AVP KO	Urine Osmolality (mOsm/kg H ₂ O)	2191 ± 38	122 ± 6	[3]
V1aRKO	Social Recognition (Investigation Time, Trial 4 vs. Trial 1)	Significant Decrease	No Significant Decrease	[9]
	% Time in Open Arms (Elevated Plus Maze)	~25%	~50%	[10]
V1bRKO	Number of Attacks (Resident-Intruder Test)	Significantly Higher	Significantly Lower	[11]
	Latency to Attack (sec) (Resident-Intruder Test)	Shorter	Longer	[12]

Experimental Protocols

Detailed methodologies are essential for the replication and validation of experimental findings. Below are protocols for key experiments cited in this guide.

Social Recognition Test

This test assesses an animal's ability to recognize a previously encountered conspecific.

- **Habituation:** The subject mouse is placed in a clean, empty cage for 30 minutes to acclimate.
- **Training Phase:** A juvenile "stimulus" mouse is introduced into the cage for a 5-minute interaction period.
- **Inter-trial Interval:** The stimulus mouse is removed.

- **Recall Phase:** After a set delay (e.g., 30 minutes or 24 hours), the same stimulus mouse (familiar) or a novel juvenile mouse is reintroduced for a 5-minute period.
- **Data Analysis:** The duration of social investigation (e.g., sniffing) is recorded for both encounters. A significant reduction in investigation time towards the familiar mouse compared to the novel mouse indicates social recognition.[11]

Resident-Intruder Aggression Test

This paradigm is used to measure offensive aggression in a territorial context.

- **Housing:** The "resident" male mouse is individually housed for at least one week to establish territory.
- **Intruder Introduction:** An unfamiliar "intruder" male mouse (typically smaller or of a non-aggressive strain) is introduced into the resident's home cage.
- **Observation:** The interaction is recorded for a set period (e.g., 10 minutes).
- **Data Analysis:** Key parameters scored include the latency to the first attack, the total number of attacks, and the cumulative duration of aggressive behaviors (e.g., biting, tail rattling).[10]
[13]

Elevated Plus Maze (EPM)

The EPM is a widely used test to assess anxiety-like behavior in rodents.

- **Apparatus:** The maze consists of four arms (two open, two enclosed by walls) arranged in a plus shape and elevated from the floor.[14]
- **Procedure:** The mouse is placed in the center of the maze and allowed to freely explore for a 5-minute session.[15][16]
- **Data Analysis:** The time spent in the open arms versus the closed arms and the number of entries into each arm are recorded. An increase in the time spent and entries into the open arms is indicative of reduced anxiety-like behavior.[15]

Mandatory Visualizations

AVP Signaling Pathway

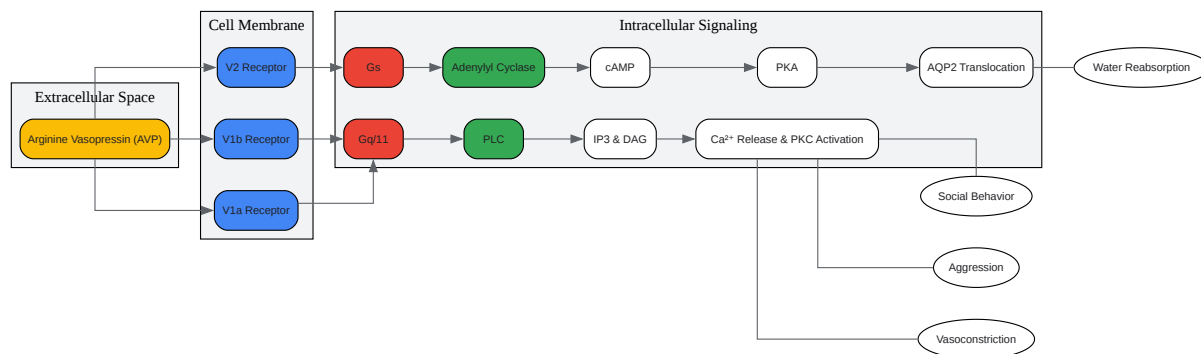

[Click to download full resolution via product page](#)

Caption: AVP signaling through V1 and V2 receptors.

Experimental Workflow for Knockout Mouse Generation and Characterization

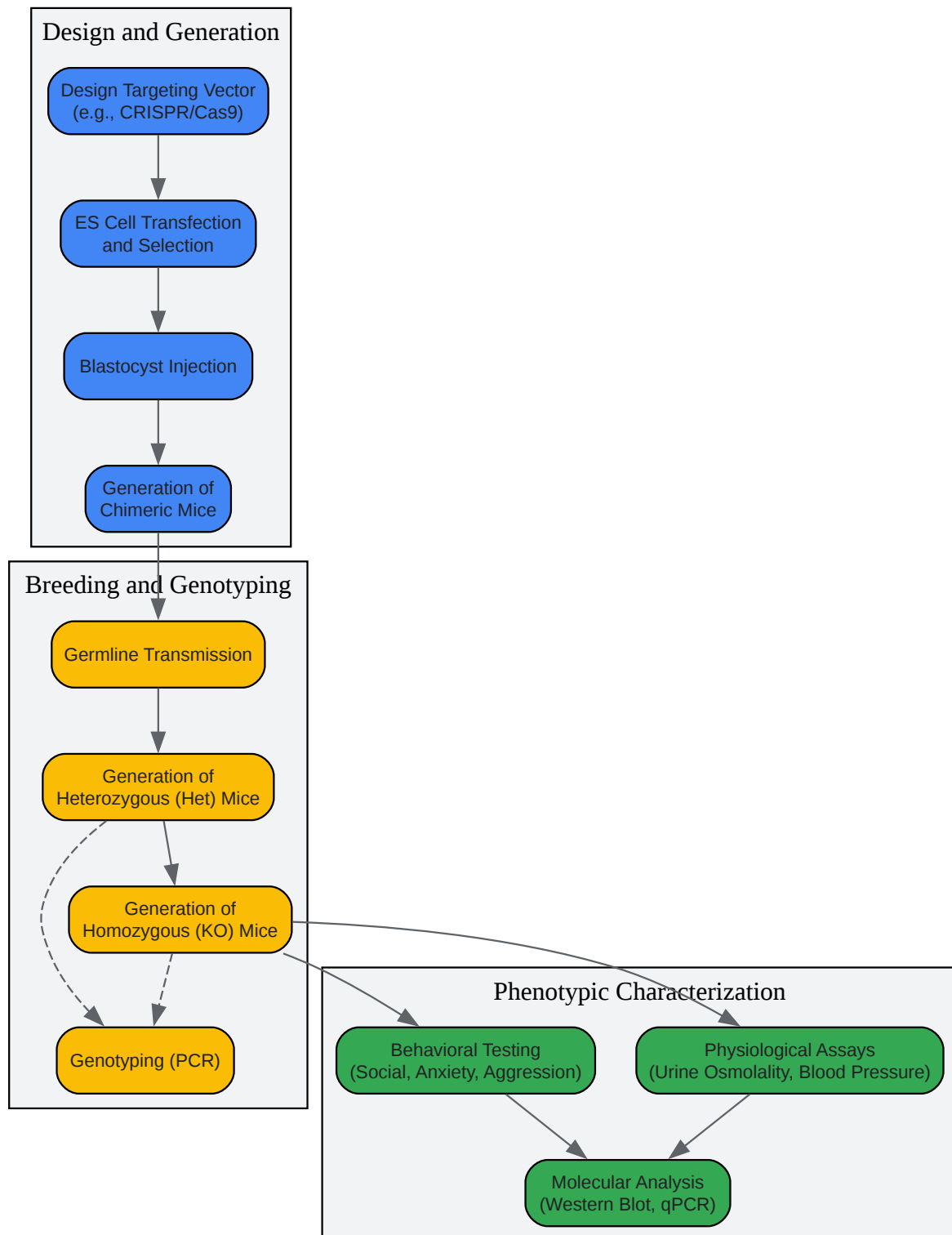

[Click to download full resolution via product page](#)

Caption: Workflow for creating and analyzing knockout mice.

Alternatives to Knockout Models

While powerful, knockout mouse models have limitations, including potential developmental compensation and the influence of genetic background. Therefore, a multi-pronged approach often yields the most robust conclusions.

- **Pharmacological Blockade:** The use of selective receptor antagonists allows for acute and reversible inhibition of AVP signaling, providing temporal and spatial control that is not possible with constitutive knockout models.[17][18] This approach is particularly useful for dissecting the immediate role of AVP in specific brain regions or physiological processes. However, the specificity and off-target effects of antagonists must be carefully considered.
- **In Vitro Systems:** Cell culture and tissue explant models offer a controlled environment to study the molecular mechanisms of AVP signaling in isolation.[19][20] These systems are invaluable for dissecting intracellular signaling cascades and for high-throughput screening of potential therapeutic compounds. However, they lack the complexity of a whole-organism system and cannot fully recapitulate the intricate behavioral and physiological responses regulated by AVP.

In conclusion, knockout mouse models are indispensable for validating the diverse functions of arginine vasopressin. By comparing the distinct phenotypes of AVP, V1a, and V1b receptor knockout mice, researchers can delineate the specific contributions of each component of the AVP system. When integrated with data from pharmacological and in vitro studies, a comprehensive understanding of AVP's role in health and disease can be achieved, paving the way for novel therapeutic interventions.

Need Custom Synthesis?

BenchChem offers custom synthesis for rare earth carbides and specific isotopic labeling.

Email: info@benchchem.com or [Request Quote Online](#).

References

- [1. Conventional Knockout Mouse Models | Genetargeting.com \[genetargeting.com\]](#)
- [2. Ingenious Blog | How A Knockout Mouse Is Made \[genetargeting.com\]](#)

- [3. journals.physiology.org \[journals.physiology.org\]](https://journals.physiology.org)
- [4. Inducible Avp knockout mouse line - PubMed \[pubmed.ncbi.nlm.nih.gov\]](https://pubmed.ncbi.nlm.nih.gov)
- [5. Profound impairment in social recognition and reduction in anxiety-like behavior in vasopressin V1a receptor knockout mice - PubMed \[pubmed.ncbi.nlm.nih.gov\]](https://pubmed.ncbi.nlm.nih.gov)
- [6. Sexual dimorphism in human bonding - Wikipedia \[en.wikipedia.org\]](https://en.wikipedia.org)
- [7. Vasopressin receptor antagonists: potential indications and clinical results - PubMed \[pubmed.ncbi.nlm.nih.gov\]](https://pubmed.ncbi.nlm.nih.gov)
- [8. JS Contractor | Philippine Recruitment Agency | Manpower Agencies \[jscon.com.ph\]](https://jscon.com.ph)
- [9. Vasopressin antagonists block peripheral as well as central vasopressin receptors - PubMed \[pubmed.ncbi.nlm.nih.gov\]](https://pubmed.ncbi.nlm.nih.gov)
- [10. researchgate.net \[researchgate.net\]](https://researchgate.net)
- [11. researchgate.net \[researchgate.net\]](https://researchgate.net)
- [12. Persistence of Reduced Aggression in Vasopressin 1b Receptor Knockout Mice on a More "Wild" Background - PMC \[pmc.ncbi.nlm.nih.gov\]](https://pmc.ncbi.nlm.nih.gov)
- [13. researchgate.net \[researchgate.net\]](https://researchgate.net)
- [14. Gene Knockout Mouse Generation - Creative Biogene CRISPR/Cas9 Platform \[creative-biogene.com\]](https://creative-biogene.com)
- [15. researchgate.net \[researchgate.net\]](https://researchgate.net)
- [16. Designing and generating a mouse model: frequently asked questions - PMC \[pmc.ncbi.nlm.nih.gov\]](https://pmc.ncbi.nlm.nih.gov)
- [17. Vasopressin receptor antagonists. Therapeutic potential in the management of acute and chronic heart failure - PubMed \[pubmed.ncbi.nlm.nih.gov\]](https://pubmed.ncbi.nlm.nih.gov)
- [18. Vasopressin and oxytocin receptors | Introduction | BPS/IUPHAR Guide to PHARMACOLOGY \[guidetopharmacology.org\]](https://guidetopharmacology.org)
- [19. pnas.org \[pnas.org\]](https://pnas.org)
- [20. Arginine Vasopressin V1a Receptor Antagonist Impairs Maternal Memory in Rats - PMC \[pmc.ncbi.nlm.nih.gov\]](https://pmc.ncbi.nlm.nih.gov)
- [To cite this document: BenchChem. \[Validating Arginine Vasopressin Function: A Comparative Guide to Knockout Mouse Models\]. BenchChem, \[2026\]. \[Online PDF\]. Available at: \[https://www.benchchem.com/product/b10846794/docs#validating-arginine-vasopressin-function-a-comparative-guide-to-knockout-mouse-models\]](https://www.benchchem.com/product/b10846794/docs#validating-arginine-vasopressin-function-a-comparative-guide-to-knockout-mouse-models)

Disclaimer & Data Validity:

The information provided in this document is for Research Use Only (RUO) and is strictly not intended for diagnostic or therapeutic procedures. While BenchChem strives to provide accurate protocols, we make no warranties, express or implied, regarding the fitness of this product for every specific experimental setup.

Technical Support: The protocols provided are for reference purposes. Unsure if this reagent suits your experiment?

Need Industrial/Bulk Grade? [Request Custom Synthesis Quote](#)

BenchChem

Our mission is to be the trusted global source of essential and advanced chemicals, empowering scientists and researchers to drive progress in science and industry.

Contact

Address: 3281 E Guasti Rd
Ontario, CA 91761, United States
Phone: (601) 213-4426
Email: info@benchchem.com

[Contact our Ph.D. Support Team for a compatibility check](#)