

# Technical Support Center: Addressing Off-Target Effects of PROTAC EGFR Degradator 3

**Author:** BenchChem Technical Support Team. **Date:** April 2026

## Compound of Interest

Compound Name: PROTAC EGFR degrader 3

Cat. No.: B10832072

[Get Quote](#)

Welcome to the technical support center for **PROTAC EGFR degrader 3** (also known as CP17). This resource is designed for researchers, scientists, and drug development professionals to provide guidance on addressing potential off-target effects during experiments. This guide includes troubleshooting advice, frequently asked questions (FAQs), detailed experimental protocols, and data summaries to support your research.

## Frequently Asked Questions (FAQs)

Q1: What is **PROTAC EGFR degrader 3** (CP17) and what is its mechanism of action?

A1: **PROTAC EGFR degrader 3** (CP17) is a potent and selective covalent PROTAC designed to target mutant forms of the Epidermal Growth Factor Receptor (EGFR) for degradation.<sup>[1][2][3][4]</sup> It consists of a ligand that binds to mutant EGFR, a ligand for the von Hippel-Lindau (VHL) E3 ubiquitin ligase, and a linker connecting the two.<sup>[2][4]</sup> This tripartite complex formation leads to the ubiquitination of the target EGFR protein and its subsequent degradation by the proteasome.<sup>[5]</sup> Studies have also indicated that the lysosome may be involved in the degradation process.<sup>[1][3][4]</sup>

Q2: How selective is **PROTAC EGFR degrader 3** for mutant EGFR over wild-type (WT) EGFR?

A2: **PROTAC EGFR degrader 3** exhibits high selectivity for mutant EGFR (e.g., EGFR<sup>L858R/T790M</sup> and EGFR<sup>del19</sup>) over WT EGFR.[1][2][3][4] This selectivity is a key feature, minimizing potential toxicity associated with targeting EGFR in healthy tissues. The high selectivity is attributed to the design of the EGFR-binding ligand, which has a higher affinity for the mutant forms of the receptor.

Q3: What are the known off-target effects of **PROTAC EGFR degrader 3**?

A3: While specific kinase panel screening data for **PROTAC EGFR degrader 3** is not widely published, global proteomic analyses of similar EGFR degraders have shown them to be highly selective for EGFR.[6] However, it is important to consider potential off-target effects inherent to PROTAC technology. These can arise from the individual components of the PROTAC (EGFR ligand or E3 ligase ligand) binding to other proteins or from the formation of unintended ternary complexes.

Q4: What are the common experimental challenges when working with **PROTAC EGFR degrader 3**?

A4: Common challenges include:

- **Suboptimal Degradation:** This could be due to issues with cell permeability, ternary complex formation, or the "hook effect" at high concentrations.
- **Observed Toxicity:** Toxicity may be on-target (due to potent EGFR degradation) or off-target.
- **Variability in Results:** Inconsistent results can stem from variations in cell lines, passage number, reagent quality, and experimental timing.

## Troubleshooting Guide

This guide provides solutions to common problems encountered during experiments with **PROTAC EGFR degrader 3**.

Problem	Potential Cause	Troubleshooting Steps
No or low EGFR degradation	Cell Permeability Issues: The PROTAC may not be efficiently entering the cells.	1. Verify the solubility of the PROTAC in your cell culture medium. 2. Consider using a different solvent or a lower percentage of DMSO. 3. Perform a cell permeability assay if the issue persists.
Suboptimal Concentration (Hook Effect): At very high concentrations, the formation of binary complexes (PROTAC-EGFR or PROTAC-VHL) can dominate over the productive ternary complex, leading to reduced degradation.	1. Perform a dose-response experiment with a wide range of concentrations (e.g., from low nanomolar to high micromolar) to identify the optimal concentration for degradation and to observe any potential hook effect.	
Incorrect Incubation Time: The kinetics of degradation can vary between cell lines.	1. Conduct a time-course experiment (e.g., 4, 8, 12, 24, 48 hours) to determine the optimal incubation time for maximal degradation.	
Low E3 Ligase Expression: The target cells may have low endogenous levels of the VHL E3 ligase.	1. Confirm the expression of VHL in your cell line by Western blot or qPCR. 2. If VHL expression is low, consider using a different cell line or a PROTAC that recruits a more abundant E3 ligase.	
Unexpected Cell Toxicity	On-Target Toxicity: Efficient degradation of EGFR, even mutant forms, can lead to cell death in dependent cell lines.	1. Correlate the timing and dose of toxicity with the timing and dose of EGFR degradation. 2. Use a rescue experiment by overexpressing a degradation-resistant form of

EGFR to confirm on-target toxicity.

Off-Target Toxicity: The PROTAC may be degrading other essential proteins.

1. Perform a global proteomics analysis (see Experimental Protocols section) to identify other degraded proteins.
2. Test a negative control PROTAC (with a modification that prevents binding to either EGFR or VHL) to see if the toxicity is independent of the intended mechanism.

Inconsistent Results

Experimental Variability:

1. Ensure consistent cell passage number and confluency.
2. Use freshly prepared PROTAC solutions for each experiment.
3. Standardize all incubation times and reagent concentrations.

## Quantitative Data Summary

The following tables summarize the reported efficacy of **PROTAC EGFR degrader 3** (CP17) in various cell lines.

Table 1: Degradation Efficacy (DC50) of **PROTAC EGFR Degradar 3**

Cell Line	EGFR Mutation	DC50 (nM)	Incubation Time
H1975	L858R/T790M	1.56	24, 48 h
HCC827	del19	0.49	24, 48 h

Data compiled from MedchemExpress and related publications.[\[3\]](#)[\[7\]](#)

Table 2: Anti-proliferative Activity (IC50) of **PROTAC EGFR Degradator 3**

Cell Line	EGFR Mutation	IC50 (nM)
H1975	L858R/T790M	32
HCC827	del19	1.60
A431	WT	>10000

Data compiled from MedchemExpress.[3]

## Experimental Protocols

### 1. Western Blot for EGFR Degradation

- Objective: To quantify the degradation of EGFR protein levels following treatment with **PROTAC EGFR degrader 3**.
- Methodology:
  - Seed cells (e.g., H1975, HCC827) in 6-well plates and allow them to adhere overnight.
  - Treat cells with a range of concentrations of **PROTAC EGFR degrader 3** (e.g., 0.1 nM to 1000 nM) and a vehicle control (e.g., DMSO) for the desired time (e.g., 24 or 48 hours).
  - Lyse the cells in RIPA buffer supplemented with protease and phosphatase inhibitors.
  - Determine protein concentration using a BCA assay.
  - Separate equal amounts of protein (e.g., 20-30 µg) on an SDS-PAGE gel.
  - Transfer the proteins to a PVDF membrane.
  - Block the membrane with 5% non-fat milk or BSA in TBST for 1 hour at room temperature.
  - Incubate the membrane with a primary antibody against EGFR overnight at 4°C.

- Incubate with a loading control antibody (e.g.,  $\beta$ -actin, GAPDH) to normalize for protein loading.
- Wash the membrane with TBST and incubate with the appropriate HRP-conjugated secondary antibody for 1 hour at room temperature.
- Visualize the protein bands using an enhanced chemiluminescence (ECL) detection system.
- Quantify band intensities using densitometry software.

## 2. Global Proteomics for Off-Target Analysis

- Objective: To identify unintended protein degradation targets of **PROTAC EGFR degrader 3**.
- Methodology:
  - Treat cells with **PROTAC EGFR degrader 3** at a concentration that gives maximal EGFR degradation and a vehicle control for a predetermined time (e.g., 24 hours).
  - Harvest and lyse the cells.
  - Perform protein digestion (e.g., using trypsin).
  - Analyze the resulting peptides by liquid chromatography-tandem mass spectrometry (LC-MS/MS).
  - Use a label-free quantification (LFQ) or stable isotope labeling by amino acids in cell culture (SILAC) approach to compare protein abundance between the treated and control samples.
  - Identify proteins that are significantly downregulated in the treated samples as potential off-targets.

## Visualizations

Below are diagrams illustrating key concepts related to the use of **PROTAC EGFR degrader 3**.

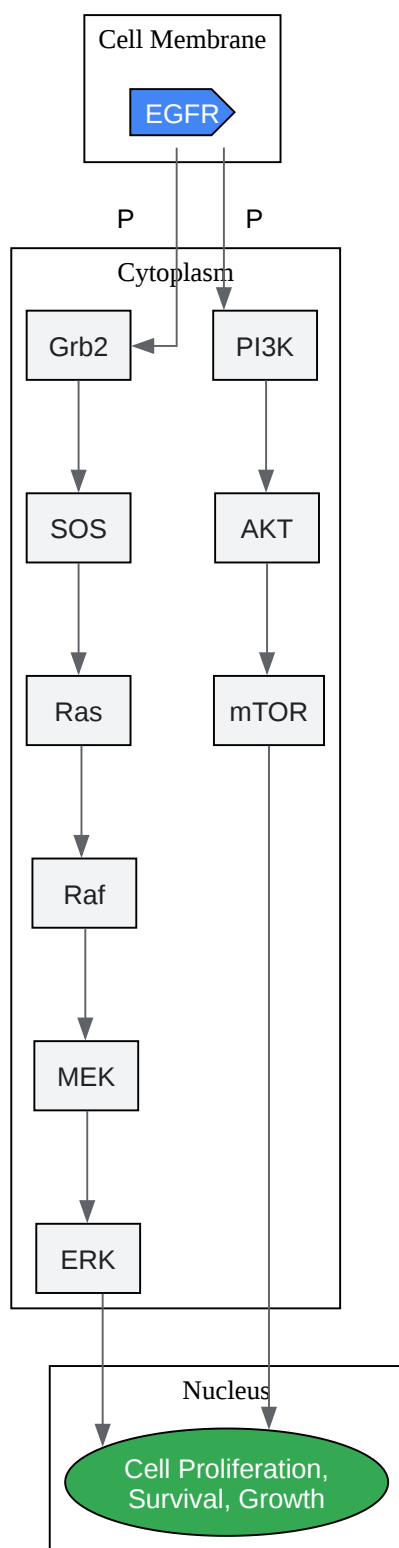

Simplified EGFR Signaling Pathway

[Click to download full resolution via product page](#)

Caption: Simplified EGFR Signaling Pathway.

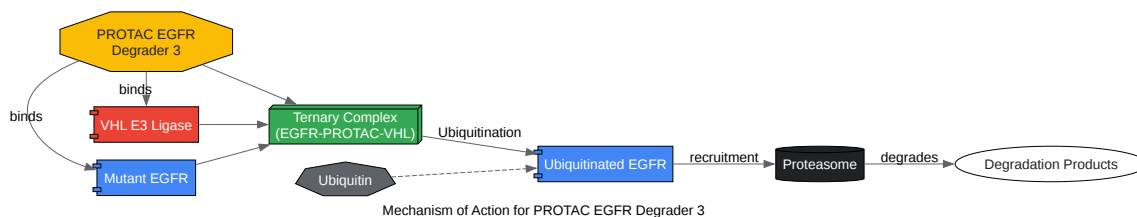

[Click to download full resolution via product page](#)

Caption: Mechanism of Action for **PROTAC EGFR Degradation 3**.

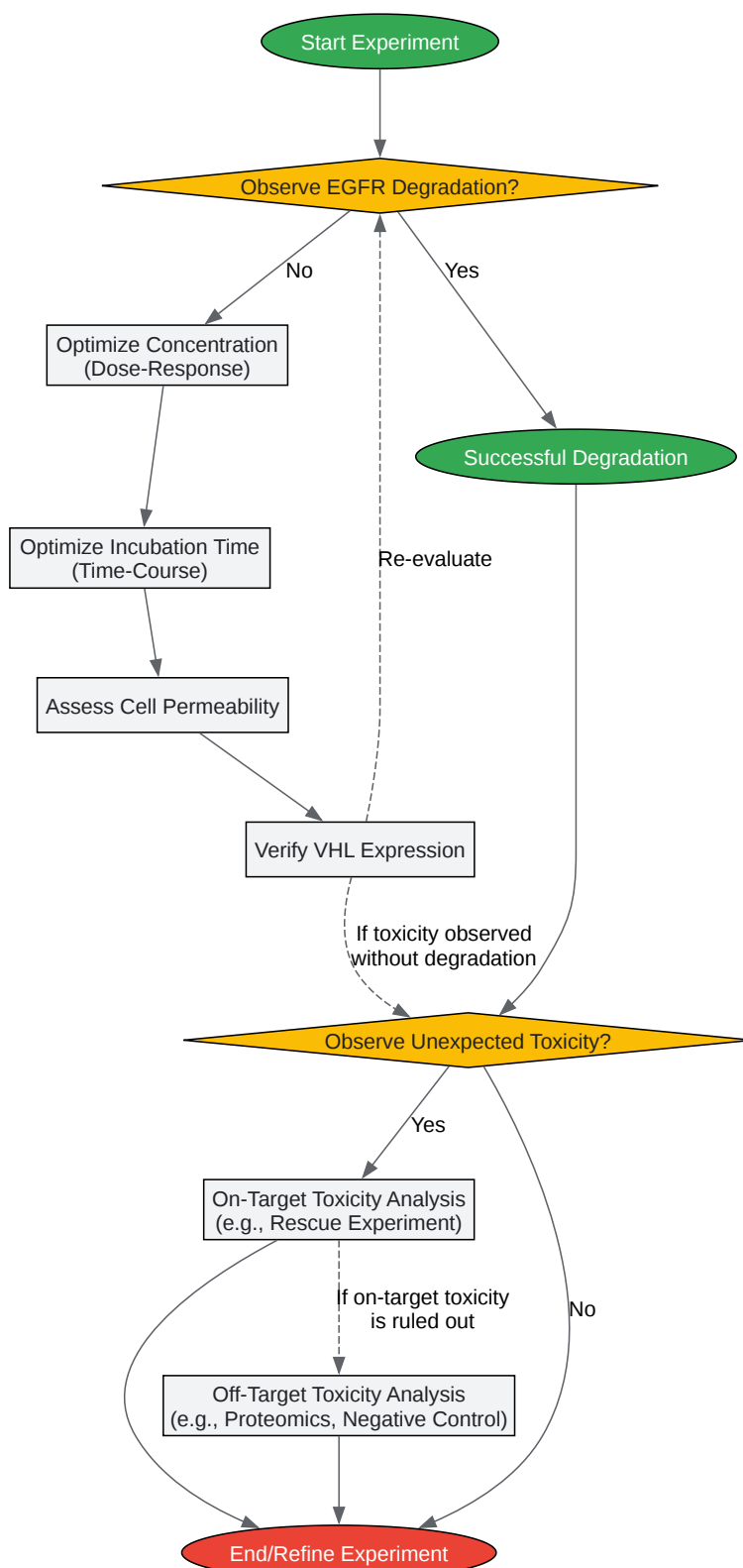

Troubleshooting Workflow for PROTAC EGFR Degradation 3 Experiments

[Click to download full resolution via product page](#)

Caption: Troubleshooting Workflow for **PROTAC EGFR Degradation 3 Experiments**.

### Need Custom Synthesis?

BenchChem offers custom synthesis for rare earth carbides and specific isotopic labeling.

Email: [info@benchchem.com](mailto:info@benchchem.com) or [Request Quote Online](#).

## References

- [1. pubs.acs.org \[pubs.acs.org\]](https://pubs.acs.org)
- [2. researchgate.net \[researchgate.net\]](https://researchgate.net)
- [3. medchemexpress.com \[medchemexpress.com\]](https://medchemexpress.com)
- [4. Discovery of Potent PROTACs Targeting EGFR Mutants through the Optimization of Covalent EGFR Ligands - PubMed \[pubmed.ncbi.nlm.nih.gov\]](#)
- [5. researchgate.net \[researchgate.net\]](https://researchgate.net)
- [6. Discovery of Potent and Selective Epidermal Growth Factor Receptor \(EGFR\) Bifunctional Small-Molecule Degraders - PMC \[pmc.ncbi.nlm.nih.gov\]](#)
- [7. Frontiers | Targeted degradation of EGFR 19Del by PROTACs suppresses tumor growth in non-small-cell lung cancer \[frontiersin.org\]](#)
- To cite this document: BenchChem. [Technical Support Center: Addressing Off-Target Effects of PROTAC EGFR Degradation 3]. BenchChem, [2026]. [Online PDF]. Available at: [\[https://www.benchchem.com/product/b10832072/docs#technical-support-center-addressing-off-target-effects-of-protac-egfr-degrader-3\]](https://www.benchchem.com/product/b10832072/docs#technical-support-center-addressing-off-target-effects-of-protac-egfr-degrader-3)

---

### Disclaimer & Data Validity:

The information provided in this document is for Research Use Only (RUO) and is strictly not intended for diagnostic or therapeutic procedures. While BenchChem strives to provide accurate protocols, we make no warranties, express or implied, regarding the fitness of this product for every specific experimental setup.

**Technical Support:** The protocols provided are for reference purposes. Unsure if this reagent suits your experiment?

**Need Industrial/Bulk Grade?** [Request Custom Synthesis Quote](#)

# BenchChem

Our mission is to be the trusted global source of essential and advanced chemicals, empowering scientists and researchers to drive progress in science and industry.

## Contact

Address: 3281 E Guasti Rd

Ontario, CA 91761, United States

Phone: (601) 213-4426

Email: [info@benchchem.com](mailto:info@benchchem.com)

[Contact our Ph.D. Support Team for a compatibility check](#)