

LX2761: A Deep Dive into SGLT1 vs. SGLT2 Selectivity

Author: BenchChem Technical Support Team. **Date:** April 2026

Compound of Interest

Compound Name: LX2761
Cat. No.: B10832737

[Get Quote](#)

An In-depth Technical Guide for Researchers and Drug Development Professionals

LX2761 is a potent, orally administered inhibitor of sodium-glucose cotransporters (SGLTs) developed for the treatment of diabetes.[1] A key characteristic of **LX2761** is its functional selectivity for SGLT1 in the gastrointestinal tract, despite demonstrating potent inhibition of both SGLT1 and SGLT2 in vitro. This technical guide provides a comprehensive overview of the SGLT1 versus SGLT2 selectivity of **LX2761**, detailing its inhibitory potency, the experimental methodologies used for its characterization, and its unique mechanism of action.

Quantitative Analysis of In Vitro Inhibition

In vitro studies are crucial for determining the intrinsic inhibitory activity of a compound against its molecular targets. For **LX2761**, its potency against human SGLT1 (hSGLT1) and human SGLT2 (hSGLT2) was evaluated using cell-based assays. The half-maximal inhibitory concentration (IC₅₀) values, which represent the concentration of the inhibitor required to reduce the transporter activity by 50%, were determined.

As the data below indicates, **LX2761** is a highly potent inhibitor of both SGLT1 and SGLT2 in a controlled in vitro environment, with IC₅₀ values in the low nanomolar range.[1][2] This

suggests that, at a molecular level, **LX2761** does not have significant intrinsic selectivity for one transporter over the other.

Transporter	IC50 (nM)
Human SGLT1 (hSGLT1)	2.2
Human SGLT2 (hSGLT2)	2.7

Mechanism of Action: Localized Inhibition in the Gastrointestinal Tract

Despite its near-equal in vitro potency against SGLT1 and SGLT2, **LX2761** is designed to act as a selective SGLT1 inhibitor in vivo.^{[1][3]} This functional selectivity is achieved through its pharmacokinetic properties. **LX2761** is minimally absorbed into the systemic circulation after oral administration, thereby restricting its action primarily to the gastrointestinal tract. Since SGLT1 is the predominant sodium-glucose cotransporter in the intestine, responsible for dietary glucose and galactose absorption, the localized presence of **LX2761** leads to a targeted inhibition of intestinal SGLT1.

This targeted action in the gut delays and reduces the absorption of glucose from food, which in turn lowers postprandial blood glucose levels. Furthermore, the increased glucose concentration in the intestinal lumen stimulates the release of glucagon-like peptide-1 (GLP-1), an incretin hormone that enhances insulin secretion and promotes satiety. The minimal systemic exposure of **LX2761** means it does not significantly inhibit SGLT2 in the kidneys, thus avoiding the glycosuria-related side effects commonly associated with systemic SGLT2 inhibitors.

A cryo-electron microscopy study has revealed the structural basis of **LX2761**'s inhibitory action on SGLT1. **LX2761** binds to the substrate-binding site of hSGLT1, locking the transporter in an outward-open conformation. This prevents the conformational changes necessary for glucose and sodium transport into the cell and also blocks the putative water permeation pathway of hSGLT1.

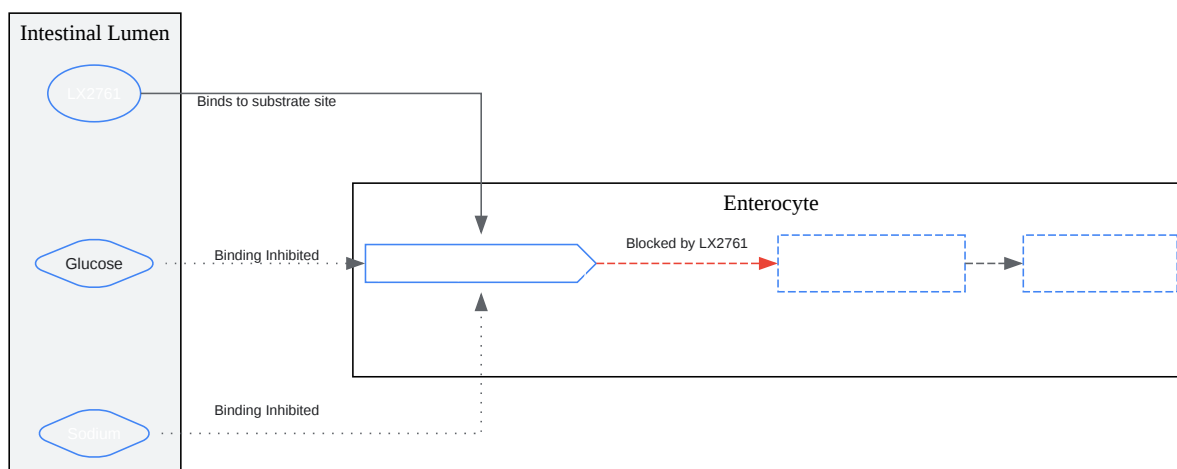

[Click to download full resolution via product page](#)

Mechanism of **LX2761** action on the SGLT1 transporter in an intestinal enterocyte.

Experimental Protocols for In Vitro Selectivity Assessment

The determination of the IC₅₀ values for **LX2761** against SGLT1 and SGLT2 involves a cell-based glucose uptake assay. The following is a generalized protocol based on standard methods for evaluating SGLT inhibitors.

1. Cell Line Maintenance:

- Human Embryonic Kidney 293 (HEK293) cells stably transfected to express either human SGLT1 (hSGLT1) or human SGLT2 (hSGLT2) are used.
- Cells are cultured in appropriate media (e.g., DMEM) supplemented with fetal bovine serum, antibiotics, and a selection agent (e.g., G418) to maintain transporter expression.

2. Glucose Uptake Assay:

- **Cell Seeding:** Cells are seeded into multi-well plates (e.g., 96-well) and grown to confluence.
- **Compound Preparation:** A serial dilution of **LX2761** is prepared in a suitable buffer.
- **Assay Buffers:** Two types of buffers are used: a sodium-containing buffer (e.g., Krebs-Ringer-Henseleit, KRH) to facilitate SGLT-mediated transport, and a sodium-free buffer (with choline chloride replacing sodium chloride) as a negative control to measure non-SGLT-mediated uptake.
- **Pre-incubation:** Cells are washed with sodium-free buffer and then pre-incubated with varying concentrations of **LX2761** in the sodium-containing buffer for a defined period (e.g., 15-30 minutes) at 37°C.
- **Uptake Initiation:** A radiolabeled, non-metabolizable glucose analogue, such as [14C]-alpha-methyl-D-glucopyranoside ([14C]-AMG), is added to each well to initiate the uptake reaction.
- **Uptake Incubation:** The plate is incubated for a specific time (e.g., 30-60 minutes) at 37°C to allow for glucose analogue transport into the cells.
- **Termination and Lysis:** The uptake is terminated by rapidly washing the cells with ice-cold sodium-free buffer to remove the extracellular radiolabeled substrate. The cells are then lysed to release the intracellular contents.
- **Quantification:** The amount of [14C]-AMG taken up by the cells is quantified using a scintillation counter.

3. Data Analysis:

- The SGLT-specific glucose uptake is calculated by subtracting the uptake in the sodium-free buffer from the uptake in the sodium-containing buffer.
- The percentage of inhibition for each concentration of **LX2761** is determined relative to the vehicle control (no inhibitor).

- The IC₅₀ value is calculated by fitting the concentration-response data to a four-parameter logistic equation using appropriate software (e.g., GraphPad Prism).

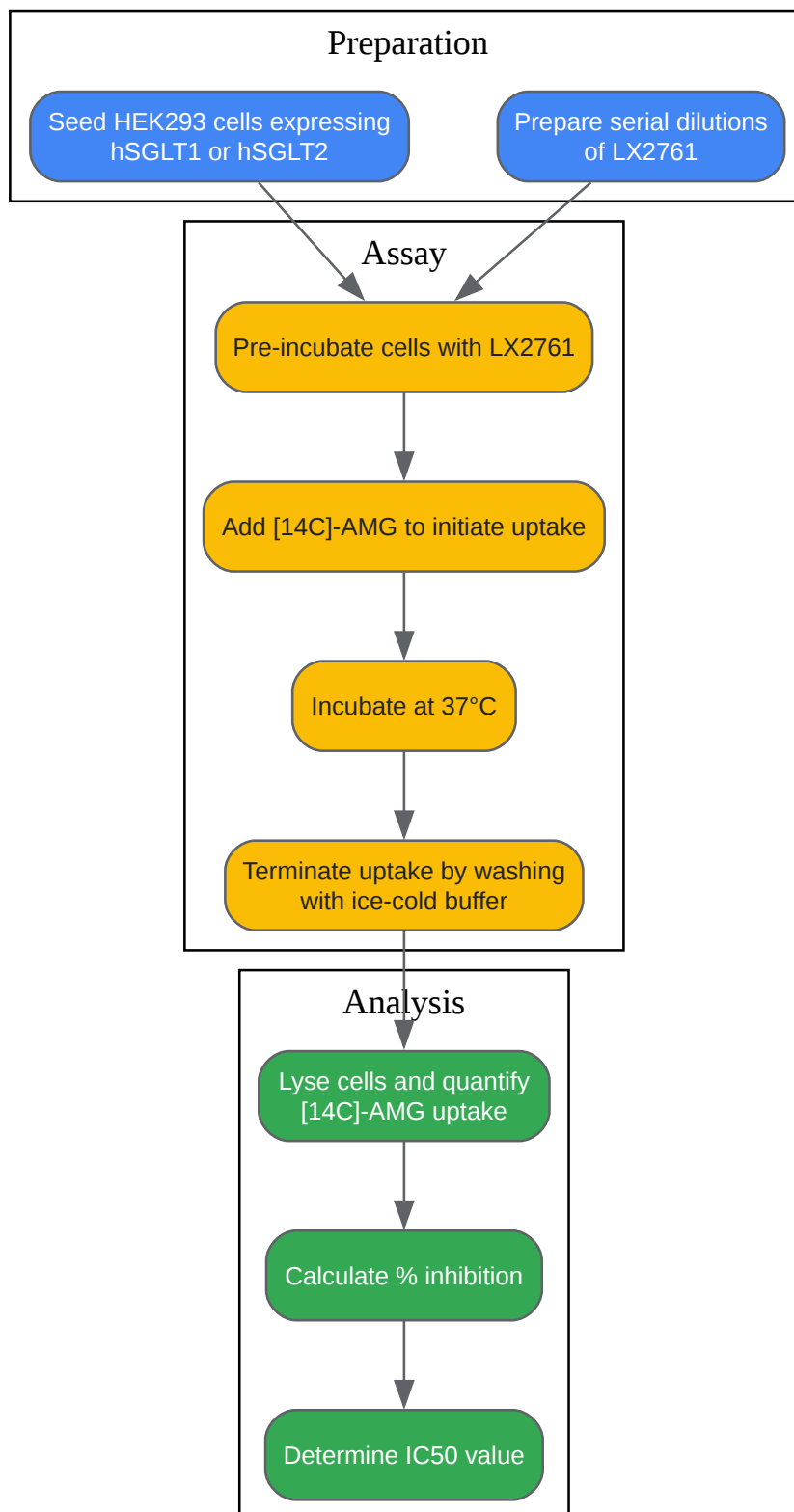

[Click to download full resolution via product page](#)

Experimental workflow for determining the in vitro IC50 of **LX2761**.

Conclusion

LX2761 represents a novel therapeutic approach for diabetes management by targeting intestinal SGLT1. While it potently inhibits both SGLT1 and SGLT2 at the molecular level, its pharmacokinetic profile, characterized by minimal systemic absorption, confers a functional selectivity for SGLT1 within the gastrointestinal tract. This localized mechanism of action allows for effective control of postprandial glucose levels and stimulation of GLP-1 release, while mitigating the risk of side effects associated with systemic SGLT2 inhibition. The in-depth understanding of its selectivity and mechanism, derived from rigorous in vitro and in vivo studies, underscores the potential of **LX2761** as a valuable addition to the armamentarium of antidiabetic agents.

Need Custom Synthesis?

BenchChem offers custom synthesis for rare earth carbides and specific isotopic labeling.

Email: info@benchchem.com or [Request Quote Online](#).

References

- [1. medchemexpress.com](https://www.medchemexpress.com) [[medchemexpress.com](https://www.medchemexpress.com)]
- [2. benchchem.com](https://www.benchchem.com) [[benchchem.com](https://www.benchchem.com)]
- [3. Pharmacological evaluation of HM41322, a novel SGLT1/2 dual inhibitor, in vitro and in vivo - PMC](#) [[pmc.ncbi.nlm.nih.gov](https://pubmed.ncbi.nlm.nih.gov/)]
- To cite this document: BenchChem. [LX2761: A Deep Dive into SGLT1 vs. SGLT2 Selectivity]. BenchChem, [2026]. [Online PDF]. Available at: [<https://www.benchchem.com/product/b10832737/docs#lx2761-a-deep-dive-into-sgl1-vs-sgl2-selectivity>]

Disclaimer & Data Validity:

The information provided in this document is for Research Use Only (RUO) and is strictly not intended for diagnostic or therapeutic procedures. While BenchChem strives to provide accurate protocols, we make no warranties, express or implied, regarding the fitness of this product for every specific experimental setup.

Technical Support: The protocols provided are for reference purposes. Unsure if this reagent suits your experiment?

Need Industrial/Bulk Grade? [Request Custom Synthesis Quote](#)

BenchChem

Our mission is to be the trusted global source of essential and advanced chemicals, empowering scientists and researchers to drive progress in science and industry.

Contact

Address: 3281 E Guasti Rd
Ontario, CA 91761, United States
Phone: (601) 213-4426
Email: info@benchchem.com

[Contact our Ph.D. Support Team for a compatibility check](#)