

Tiamulin B: A Comprehensive Technical Guide to its Molecular Targets

Author: BenchChem Technical Support Team. **Date:** April 2026

Compound of Interest

Compound Name: *tiamulin B*
Cat. No.: *B10831588*

[Get Quote](#)

For Researchers, Scientists, and Drug Development Professionals

Introduction

Tiamulin is a semi-synthetic pleuromutilin antibiotic used in veterinary medicine.^{[1][2][3]} Its efficacy stems from its ability to inhibit bacterial protein synthesis.^{[1][2][4][5]} This document provides a detailed overview of the molecular targets of tiamulin, its mechanism of action, and the experimental methodologies used to elucidate these interactions.

Primary Molecular Target: The Bacterial Ribosome

The principal molecular target of tiamulin is the 50S subunit of the bacterial ribosome.^{[2][6][7]} Specifically, it binds to the peptidyl transferase center (PTC), a critical region responsible for peptide bond formation during protein synthesis.^{[1][4][5][8]}

Mechanism of Action

Tiamulin exhibits a bacteriostatic effect at typical concentrations by inhibiting protein synthesis.^{[6][7]} At higher concentrations, it can be bactericidal.^{[6][7]} The binding of tiamulin to the PTC sterically hinders the correct positioning of the acceptor (A) and donor (P) sites of transfer RNA

(tRNA) molecules.[1][4][8] This interference prevents the formation of peptide bonds, thereby halting the elongation of the polypeptide chain and ultimately inhibiting bacterial growth.[7][8] Tiamulin's binding produces biochemically inactive initiation complexes, further preventing protein synthesis.[7]

Binding Site and Molecular Interactions

Crystallographic studies have revealed the precise binding site of tiamulin within the PTC of the 50S ribosomal subunit.[8][9] The tricyclic mutilin core of tiamulin is situated in a hydrophobic pocket at the A-tRNA binding site.[8][9] The drug's extension partially overlaps with the P-tRNA binding site.[8]

Key interactions have been identified with specific nucleotides of the 23S rRNA:

- The mutilin core stacks against the bases of G2061 and C2452, and the ribose of G2505.[9]
- Chemical footprinting experiments have shown altered reactivity of nucleotides A2058, A2059, U2506, U2584, and U2585 in the presence of tiamulin, confirming its binding at the PTC.[10]

Binding of tiamulin induces conformational changes in the ribosome, including slight movements of nucleotides A2451 and C2452.[9]

Quantitative Data on Tiamulin-Target Interactions

While the primary mode of action is well-characterized, specific quantitative binding data is not extensively detailed in the provided search results. However, some inhibitory concentrations have been reported in cell-based assays.

Cell Line	IC50 Range (µg/mL)	Reference
SH-SY5Y	2.1 to >200	[1]
HepG2	13.9 to 39.5	[1]
HEK-293	8.5 to 76.9	[1]

Signaling Pathway of Tiamulin's Action

The following diagram illustrates the inhibitory effect of tiamulin on bacterial protein synthesis.

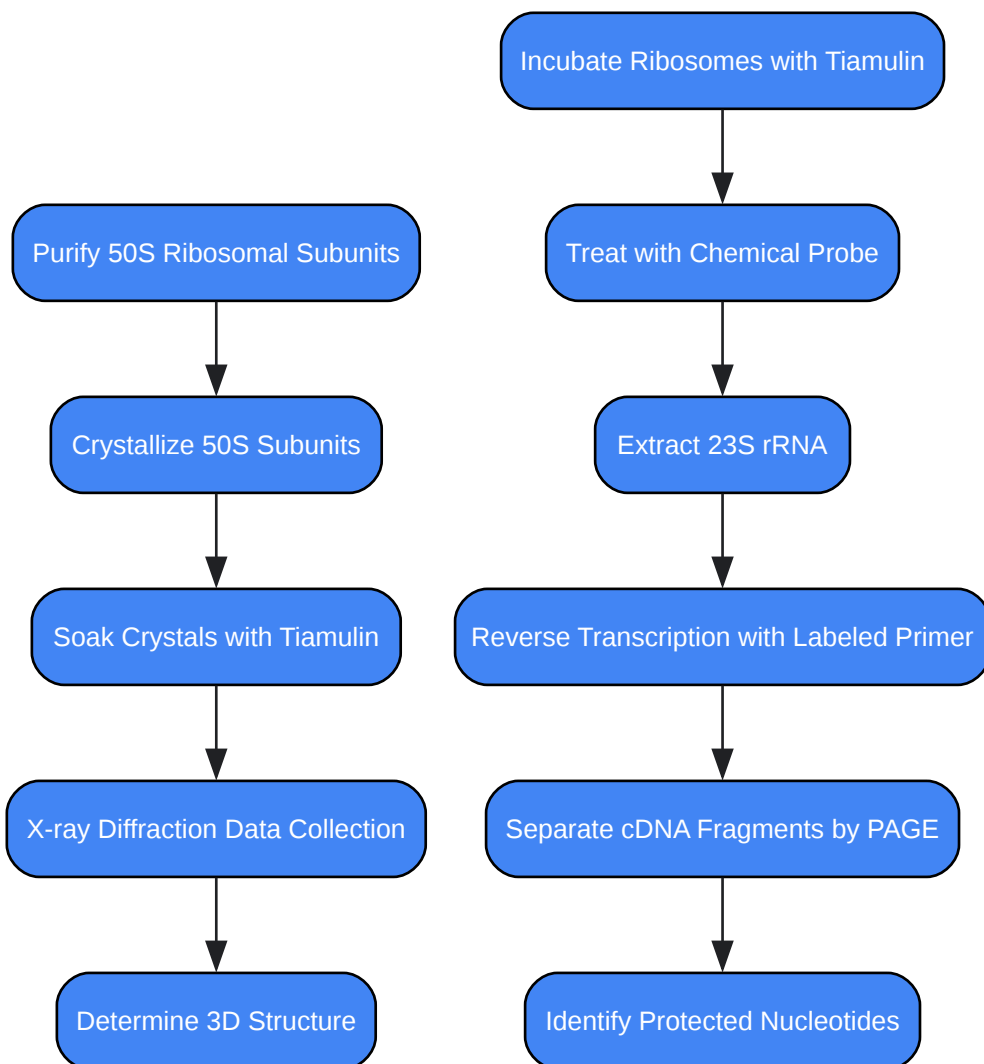
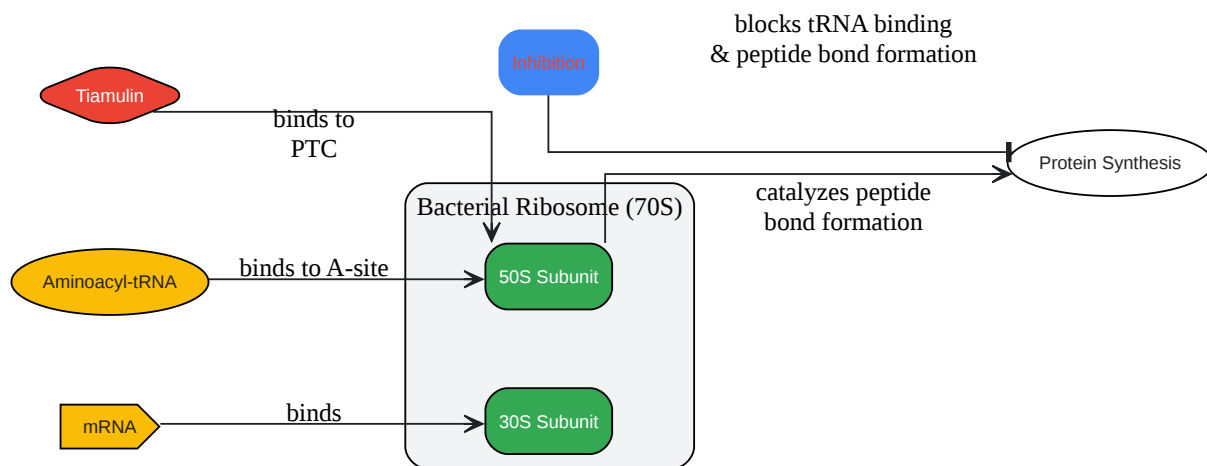

[Click to download full resolution via product page](#)

Need Custom Synthesis?

BenchChem offers custom synthesis for rare earth carbides and specific isotopic labeling.

Email: info@benchchem.com or [Request Quote Online](#).

References

- [1. researchgate.net \[researchgate.net\]](https://www.researchgate.net)
- [2. taylorandfrancis.com \[taylorandfrancis.com\]](https://www.taylorandfrancis.com)
- [3. go.drugbank.com \[go.drugbank.com\]](https://go.drugbank.com)
- [4. Analysis of Transfer of Tiamulin to Animal Tissue after Oral Administration: An Important Factor for Ensuring Food Safety and Environmental Protection - PMC \[pmc.ncbi.nlm.nih.gov\]](#)
- [5. selleckchem.com \[selleckchem.com\]](https://www.selleckchem.com)
- [6. arpi.unipi.it \[arpi.unipi.it\]](https://www.arpi.unipi.it)
- [7. Pharmacological particulars - Tialin® Solution for Use in Drinking Water for Pigs, Chickens and Turkeys \[noahcompendium.co.uk\]](https://www.noahcompendium.co.uk)
- [8. Inhibition of peptide bond formation by pleuromutilins: the structure of the 50S ribosomal subunit from Deinococcus radiodurans in complex with tiamulin - PubMed \[pubmed.ncbi.nlm.nih.gov\]](#)
- [9. U2504 Determines the Species Specificity of the A-site Cleft Antibiotics. The Structures of Tiamulin, Homoharringtonine and Bruceantin Bound to the Ribosome - PMC \[pmc.ncbi.nlm.nih.gov\]](#)
- [10. Resistance to the Peptidyl Transferase Inhibitor Tiamulin Caused by Mutation of Ribosomal Protein L3 - PMC \[pmc.ncbi.nlm.nih.gov\]](#)
- To cite this document: BenchChem. [Tiamulin B: A Comprehensive Technical Guide to its Molecular Targets]. BenchChem, [2026]. [Online PDF]. Available at: [\[https://www.benchchem.com/product/b10831588/docs#tiamulin-b-a-comprehensive-technical-guide-to-its-molecular-targets\]](https://www.benchchem.com/product/b10831588/docs#tiamulin-b-a-comprehensive-technical-guide-to-its-molecular-targets)

Disclaimer & Data Validity:

The information provided in this document is for Research Use Only (RUO) and is strictly not intended for diagnostic or therapeutic procedures. While BenchChem strives to provide accurate protocols, we make no warranties, express or implied, regarding the fitness of this product for every specific experimental setup.

Technical Support: The protocols provided are for reference purposes. Unsure if this reagent suits your experiment?

Need Industrial/Bulk Grade? [Request Custom Synthesis Quote](#)

BenchChem

Our mission is to be the trusted global source of essential and advanced chemicals, empowering scientists and researchers to drive progress in science and industry.

Contact

Address: 3281 E Guasti Rd
Ontario, CA 91761, United States
Phone: (601) 213-4426
Email: info@benchchem.com

[Contact our Ph.D. Support Team for a compatibility check](#)