

Technical Support Center: NRX-103094

Experiments

Author: BenchChem Technical Support Team. **Date:** April 2026

Compound of Interest

Compound Name: NRX-103094

Cat. No.: B10831376

[Get Quote](#)

This technical support center provides troubleshooting guidance and frequently asked questions for researchers and scientists working with the novel selective Kinase Alpha inhibitor, **NRX-103094**.

Frequently Asked Questions (FAQs)

Q1: What is the primary mechanism of action for **NRX-103094**?

A1: **NRX-103094** is a potent and selective small molecule inhibitor of Kinase Alpha, a critical component of the MAPK/ERK signaling pathway. By binding to the ATP-binding pocket of Kinase Alpha, **NRX-103094** prevents its phosphorylation and subsequent activation of downstream targets.

Q2: What is the recommended solvent and storage condition for **NRX-103094**?

A2: For in vitro experiments, **NRX-103094** should be dissolved in dimethyl sulfoxide (DMSO) to create a stock solution of 10-50 mM. This stock solution should be stored at -20°C or -80°C and be protected from light. For in vivo studies, the optimal vehicle for administration should be determined empirically, but common starting points include a solution of 5% DMSO, 40% PEG300, 5% Tween 80, and 50% saline.

Q3: How can I confirm that **NRX-103094** is active in my cell line?

A3: The most direct method to confirm the activity of **NRX-103094** is to perform a Western blot analysis. You should observe a dose-dependent decrease in the phosphorylation of downstream targets of Kinase Alpha, such as MEK1/2 and ERK1/2, upon treatment with **NRX-103094**.

Troubleshooting Guides

Issue 1: Inconsistent or No Inhibition of Kinase Alpha Activity

If you are observing variability or a complete lack of inhibitory effect from **NRX-103094** in your experiments, consider the following troubleshooting steps.

Troubleshooting Steps:

- **Verify Compound Integrity:** Ensure that **NRX-103094** has been stored correctly and has not undergone multiple freeze-thaw cycles, which can degrade the compound.
- **Confirm Solubility:** After dilution in your cell culture medium, visually inspect the solution for any precipitation of the compound. If precipitation is observed, consider lowering the final concentration or using a different formulation.
- **Check Cell Line Responsiveness:** Confirm that your chosen cell line expresses Kinase Alpha and that the MAPK/ERK pathway is active. You can do this by running a baseline Western blot to check for phosphorylated ERK.
- **Optimize Treatment Duration and Concentration:** It is possible that the concentration range or the incubation time is not optimal for your specific cell line. Perform a dose-response and time-course experiment to determine the optimal conditions.

Issue 2: High Cellular Toxicity or Off-Target Effects

If you are observing significant cell death or unexpected cellular phenotypes that are inconsistent with the inhibition of the Kinase Alpha pathway, you may be encountering off-target effects or compound toxicity.

Troubleshooting Steps:

- Perform a Dose-Response Cytotoxicity Assay: Use a lower concentration range of **NRX-103094** to identify a non-toxic working concentration. Assays such as MTT or a live/dead cell stain can be used.
- Include a Rescue Experiment: To confirm that the observed phenotype is due to the inhibition of Kinase Alpha, attempt to "rescue" the effect by introducing a constitutively active form of a downstream effector.
- Use a Structurally Unrelated Kinase Alpha Inhibitor: If possible, compare the effects of **NRX-103094** with another known Kinase Alpha inhibitor that has a different chemical scaffold. This can help differentiate on-target from off-target effects.

Experimental Protocols & Data

Protocol: Western Blot for Phospho-ERK1/2 Inhibition

- Cell Seeding: Seed $1-2 \times 10^6$ cells per well in a 6-well plate and allow them to adhere overnight.
- Serum Starvation: The following day, replace the medium with a serum-free medium and incubate for 12-24 hours to reduce basal pathway activation.
- **NRX-103094** Treatment: Treat the cells with a range of **NRX-103094** concentrations (e.g., 0, 0.1, 1, 10, 100, 1000 nM) for 2-4 hours.
- Cell Lysis: Wash the cells with ice-cold PBS and then lyse them in RIPA buffer supplemented with protease and phosphatase inhibitors.
- Protein Quantification: Determine the protein concentration of each lysate using a BCA assay.
- SDS-PAGE and Transfer: Load equal amounts of protein onto an SDS-PAGE gel, separate the proteins by electrophoresis, and then transfer them to a PVDF membrane.
- Immunoblotting: Block the membrane and then probe with primary antibodies against phospho-ERK1/2, total ERK1/2, and a loading control (e.g., GAPDH). Subsequently,

incubate with the appropriate secondary antibodies.

- Detection: Visualize the protein bands using a chemiluminescence detection system.

Table 1: In Vitro Kinase Assay - NRX-103094 Inhibition of Kinase Alpha

Concentration (nM)	% Inhibition	IC50 (nM)
1	15.2	\multirow{5}{*}{25.4}
10	45.8	
25	51.2	
50	78.6	
100	95.3	

Table 2: Cell Viability (MTT Assay) - 72h NRX-103094 Treatment

Cell Line	IC50 (μM)
Cell Line A (Kinase Alpha Dependent)	0.5
Cell Line B (Kinase Alpha Independent)	> 50

Visualizations

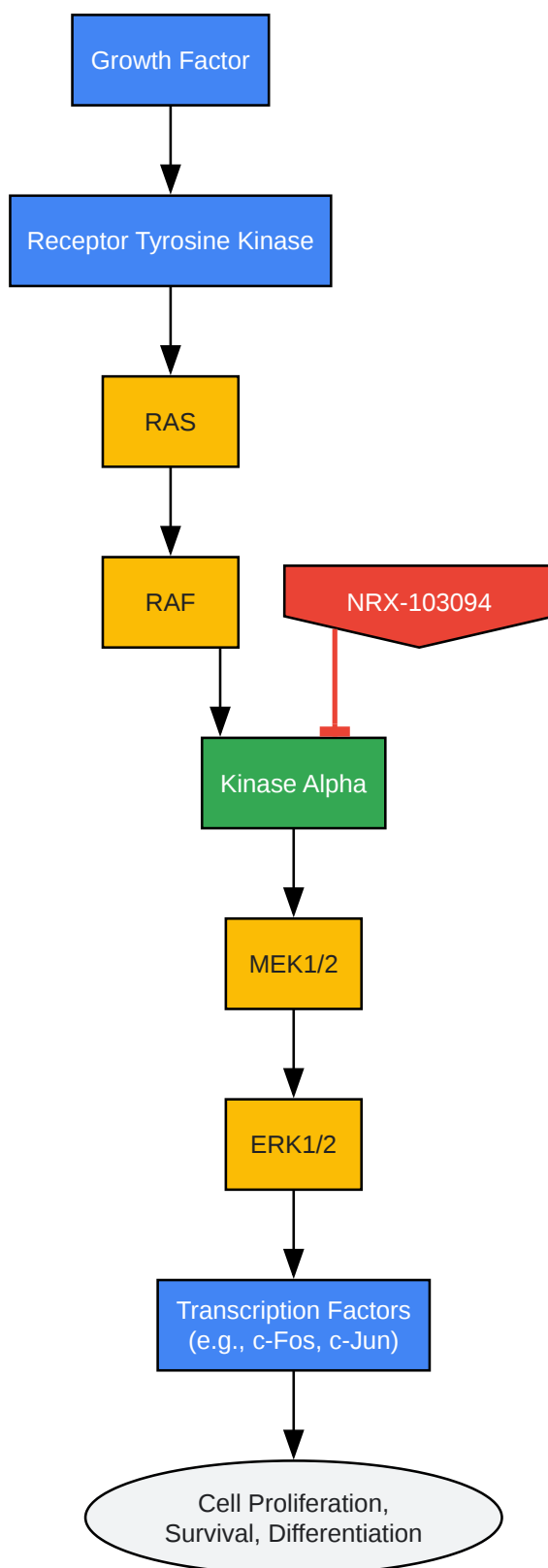

[Click to download full resolution via product page](#)

Caption: Simplified MAPK/ERK signaling pathway showing the inhibitory action of **NRX-103094** on Kinase Alpha.

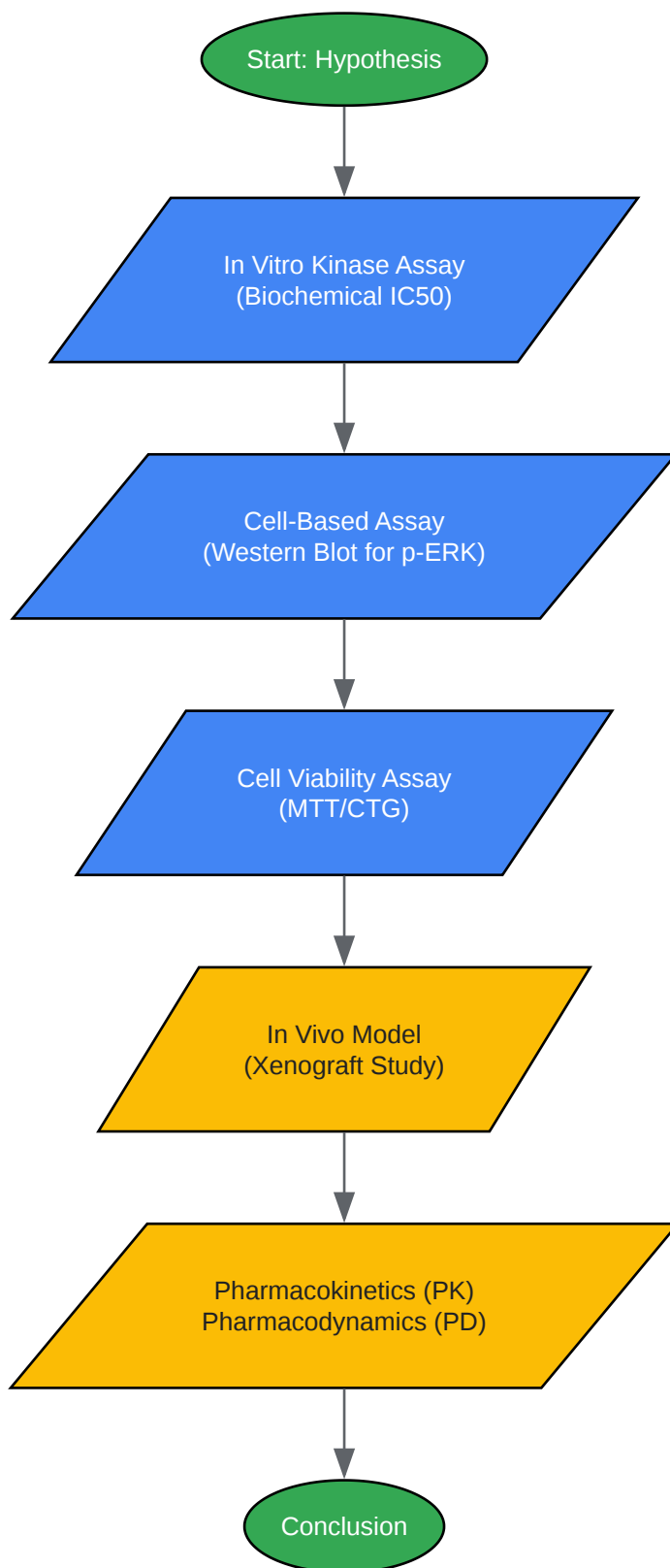

[Click to download full resolution via product page](#)

Caption: General experimental workflow for the preclinical evaluation of **NRX-103094**.

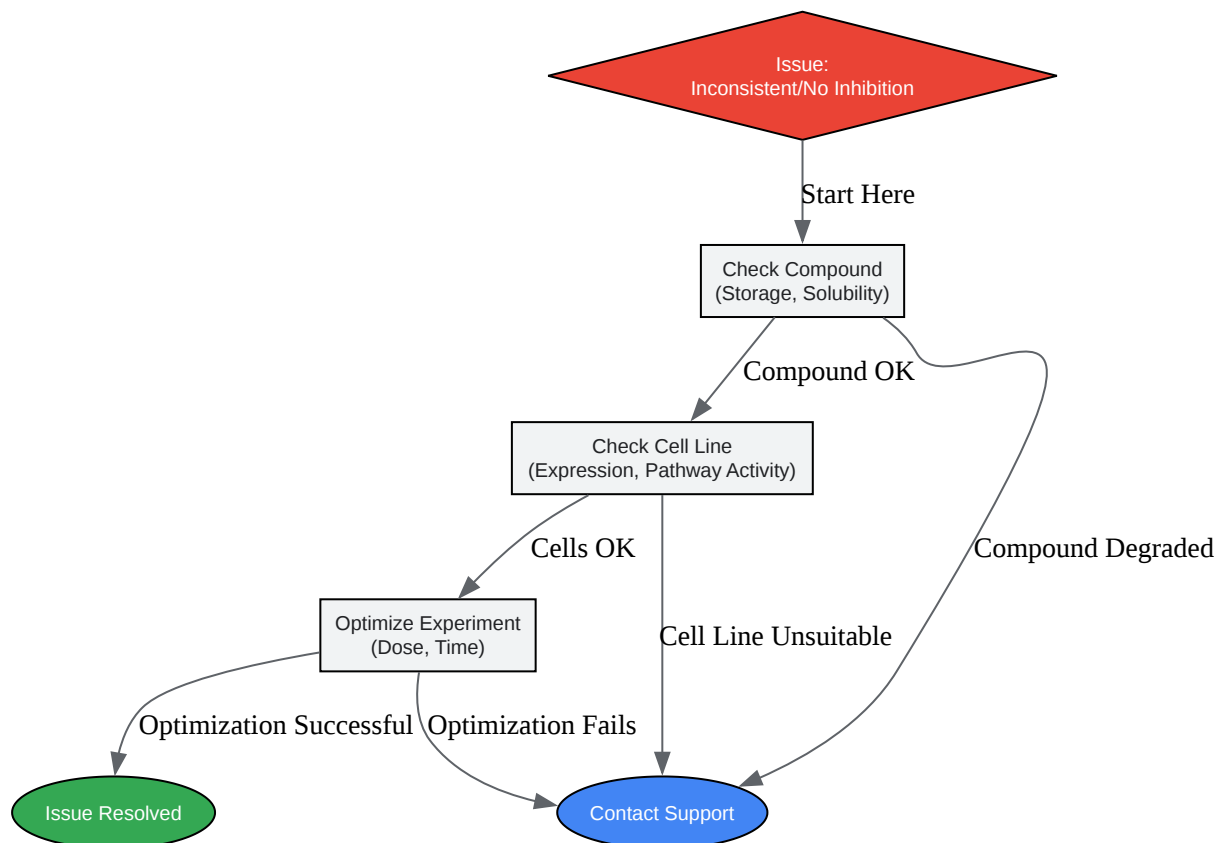

[Click to download full resolution via product page](#)

Caption: A decision tree for troubleshooting inconsistent results in **NRX-103094** experiments.

- To cite this document: BenchChem. [Technical Support Center: NRX-103094 Experiments]. BenchChem, [2026]. [Online PDF]. Available at: [\[https://www.benchchem.com/product/b10831376/docs#technical-support-center-nrx-103094-experiments\]](https://www.benchchem.com/product/b10831376/docs#technical-support-center-nrx-103094-experiments)

Disclaimer & Data Validity:

The information provided in this document is for Research Use Only (RUO) and is strictly not intended for diagnostic or therapeutic procedures. While BenchChem strives to provide accurate protocols, we make no warranties, express or implied, regarding the fitness of this product for every specific experimental setup.

Technical Support: The protocols provided are for reference purposes. Unsure if this reagent suits your experiment?

Need Industrial/Bulk Grade? [Request Custom Synthesis Quote](#)

BenchChem

Our mission is to be the trusted global source of essential and advanced chemicals, empowering scientists and researchers to drive progress in science and industry.

Contact

Address: 3281 E Guasti Rd
Ontario, CA 91761, United States
Phone: (601) 213-4426
Email: info@benchchem.com

[Contact our Ph.D. Support Team for a compatibility check](#)