

SAE-14 Protocol for Comprehensive Western Blot Analysis

Author: BenchChem Technical Support Team. **Date:** April 2026

Compound of Interest

Compound Name: SAE-14
Cat. No.: B10831564

[Get Quote](#)

Application Note ID: **SAE-14-WB** Revision: 1.0 For Research Use Only. Not for use in diagnostic procedures.

Abstract

Western blotting is a cornerstone technique in molecular biology, enabling the detection, identification, and quantification of specific proteins within a complex mixture.[1][2][3][4] The **SAE-14** protocol described herein provides a robust and detailed workflow for western blot analysis, designed for researchers, scientists, and drug development professionals. This document outlines procedures from sample preparation to data analysis, includes quantitative data tables for reference, and provides visual diagrams of experimental workflows and a key signaling pathway commonly analyzed by this method.

Introduction to Western Blotting

Western blotting, or immunoblotting, combines the protein-separating power of polyacrylamide gel electrophoresis (SDS-PAGE) with the high specificity of antibody-antigen binding.[4][5] The fundamental steps of the process include:

- Sample Preparation: Extraction and quantification of proteins from cells or tissues.[6][7]

- Gel Electrophoresis: Separation of proteins based on their molecular weight.[2][6]
- Protein Transfer: Transfer of separated proteins from the gel to a solid membrane (e.g., PVDF or nitrocellulose).[8][9][10]
- Immunodetection: Probing the membrane with specific primary and secondary antibodies to identify the target protein.[5][11]
- Visualization: Detection of the antibody-protein complex using methods such as chemiluminescence or fluorescence.[1][11]

This technique is widely used to assess protein expression levels, identify post-translational modifications, and analyze signaling pathways.[12][13]

Experimental Protocols

This section provides a step-by-step methodology for performing western blot analysis using the **SAE-14** protocol.

Sample Preparation

Proper sample preparation is critical for accurate and reproducible results.[6]

- Cell Lysis:
 - For adherent cells, wash the culture dish on ice with ice-cold Phosphate-Buffered Saline (PBS).[7][8]
 - Add ice-cold RIPA lysis buffer supplemented with protease and phosphatase inhibitors to the dish (e.g., 1 mL per 10 cm dish).[6][8]
 - Scrape the cells and transfer the lysate to a pre-chilled microcentrifuge tube.[7][8][14]
 - Agitate the lysate for 30 minutes at 4°C.[8]
 - Centrifuge at 12,000 rpm for 20 minutes at 4°C to pellet cellular debris.[7]
 - Carefully transfer the supernatant (protein extract) to a new, pre-chilled tube.[7]

- Protein Quantification:
 - Determine the protein concentration of each lysate using a standard colorimetric assay, such as the bicinchoninic acid (BCA) or Bradford assay.[6][7][15] This step is crucial for ensuring equal loading of protein across all lanes of the gel.[15][16]
- Sample Denaturation:
 - Mix the protein lysate with 2X Laemmli sample buffer at a 1:1 ratio.[17]
 - Heat the samples at 95-100°C for 5-10 minutes to denature the proteins.[8][16][18]
 - Briefly centrifuge the samples to collect the contents at the bottom of the tube.[16][18]

SDS-PAGE (Gel Electrophoresis)

- Gel Preparation: Use a precast polyacrylamide gel or hand-cast a gel with a percentage appropriate for the molecular weight of the target protein.[8][17]
- Sample Loading:
 - Load 10-50 µg of total protein per lane into the wells of the gel.[8]
 - Include a pre-stained molecular weight marker in one lane to monitor protein separation and transfer efficiency.[19]
- Electrophoresis:
 - Place the gel into the electrophoresis chamber and fill it with 1X Tris-Glycine SDS Running Buffer.[14][19]
 - Run the gel at a constant voltage (e.g., 100-150 V) for 1-2 hours, or until the dye front reaches the bottom of the gel.[8][20]

Protein Transfer (Blotting)

- Membrane Preparation:

- Cut a piece of polyvinylidene difluoride (PVDF) or nitrocellulose membrane to the size of the gel.[17]
- If using PVDF, activate the membrane by soaking it in methanol for 30-60 seconds, followed by a brief rinse in deionized water and then equilibration in 1X Transfer Buffer.[8][17]
- Transfer Sandwich Assembly:
 - Assemble the transfer "sandwich" in the following order: sponge, filter paper, gel, membrane, filter paper, sponge. Ensure no air bubbles are trapped between the gel and the membrane.
- Electrotransfer:
 - Place the sandwich into a transfer cassette and perform the transfer. Two common methods are:
 - Wet Transfer: Recommended for most proteins, especially those with low molecular weight (<30 kDa). Typically run for 1 hour at 100 V in a cold room (4°C).[8]
 - Semi-Dry Transfer: Faster method, well-suited for larger proteins (>100 kDa).[8][12]
 - Ensure the membrane is oriented towards the positive electrode (anode) and the gel towards the negative electrode (cathode).[20]

Immunodetection

- Blocking:
 - After transfer, wash the membrane briefly with 1X Tris-Buffered Saline with Tween 20 (TBST).
 - Incubate the membrane in a blocking buffer (e.g., 5% non-fat dry milk or 5% Bovine Serum Albumin (BSA) in TBST) for 1 hour at room temperature with gentle agitation.[21] This step prevents non-specific binding of antibodies to the membrane.[5]
- Primary Antibody Incubation:

- Dilute the primary antibody specific to the target protein in blocking buffer at the manufacturer's recommended concentration.
- Incubate the membrane with the primary antibody solution overnight at 4°C with gentle shaking.[14]
- Washing:
 - Wash the membrane three times with TBST for 10 minutes each to remove unbound primary antibody.[21]
- Secondary Antibody Incubation:
 - Dilute the enzyme-conjugated secondary antibody (e.g., HRP-conjugated) in blocking buffer. The secondary antibody must recognize the host species of the primary antibody. [11]
 - Incubate the membrane with the secondary antibody solution for 1 hour at room temperature with gentle agitation.[21]
- Final Washes:
 - Wash the membrane three to six times with TBST for 10 minutes each to remove unbound secondary antibody.[17][21]

Signal Detection and Analysis

- Chemiluminescent Detection:
 - Prepare the Enhanced Chemiluminescent (ECL) substrate according to the manufacturer's instructions.[21]
 - Incubate the membrane completely with the ECL substrate for 1-5 minutes.[21]
 - Capture the chemiluminescent signal using an imaging system (e.g., CCD camera-based imager) or by exposing it to autoradiography film.[1][21]
- Data Analysis:

- Perform densitometry analysis on the captured image to quantify the intensity of the protein bands.
- Normalize the target protein signal to a loading control (e.g., a housekeeping protein like GAPDH or β -actin, or total protein stain) to correct for variations in sample loading.[22][23]
- Calculate the relative protein expression by comparing the normalized intensity of the target protein across different samples.[23]

Data Presentation

Quantitative data from western blot experiments should be carefully recorded and presented. The tables below provide examples of typical parameters and results.

Table 1: Antibody Dilution and Protein Loading Parameters

Parameter	Target Protein (e.g., p-ERK)	Loading Control (e.g., GAPDH)
Protein Load per Lane	25 μ g	25 μ g
Primary Antibody	Rabbit anti-p-ERK	Mouse anti-GAPDH
Primary Antibody Dilution	1:1000 in 5% BSA/TBST	1:5000 in 5% Milk/TBST
Secondary Antibody	Goat anti-Rabbit IgG-HRP	Goat anti-Mouse IgG-HRP
Secondary Antibody Dilution	1:2000 in 5% Milk/TBST	1:10000 in 5% Milk/TBST

| Incubation Time (Primary) | Overnight at 4°C | 1 hour at RT |

Table 2: Sample Densitometry and Normalized Expression Data

Sample ID	Target (p-ERK) Raw Intensity	Control (GAPDH) Raw Intensity	Normalized Intensity (Target/Control)	Fold Change (vs. Control A)
Control A	85,430	150,210	0.569	1.00
Control B	88,120	155,600	0.566	0.99
Treated A	255,900	148,950	1.718	3.02

| Treated B | 268,300 | 151,100 | 1.776 | 3.12 |

Visualization of Workflows and Pathways

Diagrams created using Graphviz (DOT language) help visualize complex processes and relationships.

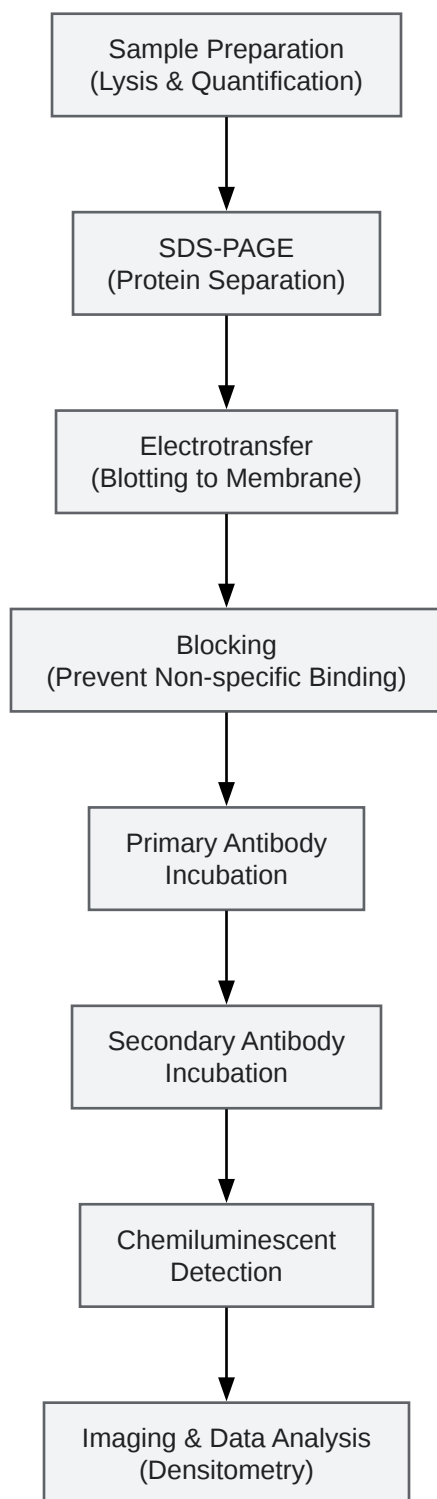

[Click to download full resolution via product page](#)

Caption: **SAE-14** Western Blot Experimental Workflow.

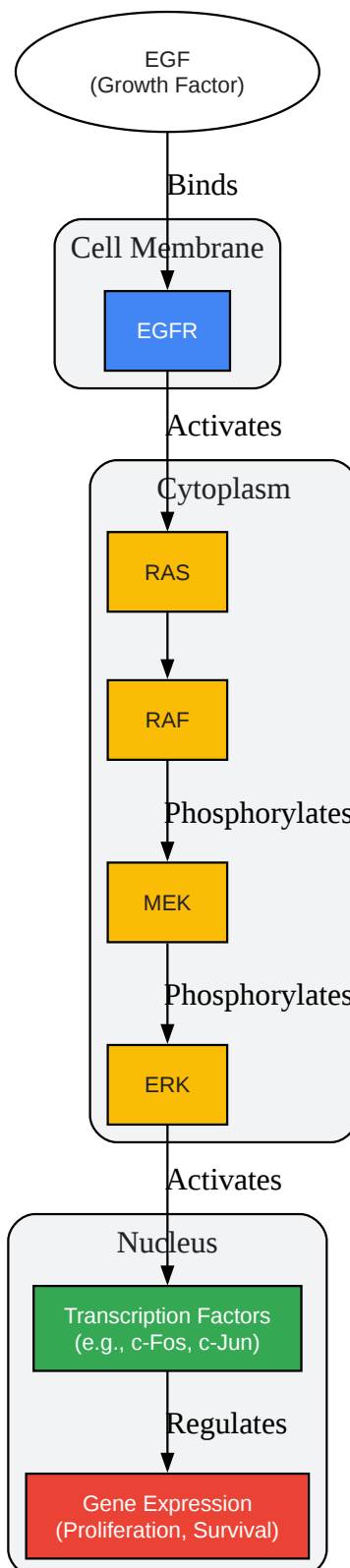

[Click to download full resolution via product page](#)

Caption: MAPK/ERK Signaling Pathway Analyzed by Western Blot.

Need Custom Synthesis?

BenchChem offers custom synthesis for rare earth carbides and specific isotopic labeling.

Email: info@benchchem.com or [Request Quote Online](#).

References

- [1. Western blot - Wikipedia \[en.wikipedia.org\]](#)
- [2. Western Blot: Technique, Theory, and Trouble Shooting - PMC \[pmc.ncbi.nlm.nih.gov\]](#)
- [3. Western Blotting | Immunoblotting | BD Biosciences \[bdbiosciences.com\]](#)
- [4. Western Blotting \(Immunoblot\): Gel Electrophoresis for Proteins \[antibodies-online.com\]](#)
- [5. Western Blotting: Products, Protocols, & Applications | Thermo Fisher Scientific - HK \[thermofisher.com\]](#)
- [6. What Is Western Blot? A Step-by-Step Guide to Protein Detection \[synapse.patsnap.com\]](#)
- [7. Sample preparation for western blot | Abcam \[abcam.com\]](#)
- [8. General Western Blot Protocol Overview: Novus Biologicals \[novusbio.com\]](#)
- [9. microbenotes.com \[microbenotes.com\]](#)
- [10. fishersci.co.uk \[fishersci.co.uk\]](#)
- [11. bio-rad.com \[bio-rad.com\]](#)
- [12. Western Blot: The Complete Guide | Antibodies.com \[antibodies.com\]](#)
- [13. Analysis of Signaling Pathways by Western Blotting and Immunoprecipitation - PubMed \[pubmed.ncbi.nlm.nih.gov\]](#)
- [14. Western Blot Procedure | Cell Signaling Technology \[cellsignal.com\]](#)
- [15. goldbio.com \[goldbio.com\]](#)
- [16. info.gbiosciences.com \[info.gbiosciences.com\]](#)
- [17. bosterbio.com \[bosterbio.com\]](#)
- [18. Introduction to SDS-PAGE - Separation of Proteins Based on Size \[sigmaaldrich.com\]](#)
- [19. SDS-PAGE Protocol | Rockland \[rockland.com\]](#)
- [20. bostonbioproducts.com \[bostonbioproducts.com\]](#)
- [21. Western Blot Protocol | Proteintech Group \[ptglab.com\]](#)

- [22. Quantitative Western Blot Analysis | Thermo Fisher Scientific - US \[thermofisher.com\]](#)
- [23. protocols.io \[protocols.io\]](#)
- To cite this document: BenchChem. [SAE-14 Protocol for Comprehensive Western Blot Analysis]. BenchChem, [2026]. [Online PDF]. Available at: [\[https://www.benchchem.com/product/b10831564/docs#sae-14-protocol-for-comprehensive-western-blot-analysis\]](https://www.benchchem.com/product/b10831564/docs#sae-14-protocol-for-comprehensive-western-blot-analysis)

Disclaimer & Data Validity:

The information provided in this document is for Research Use Only (RUO) and is strictly not intended for diagnostic or therapeutic procedures. While BenchChem strives to provide accurate protocols, we make no warranties, express or implied, regarding the fitness of this product for every specific experimental setup.

Technical Support: The protocols provided are for reference purposes. Unsure if this reagent suits your experiment?

Need Industrial/Bulk Grade? [Request Custom Synthesis Quote](#)

BenchChem

Our mission is to be the trusted global source of essential and advanced chemicals, empowering scientists and researchers to drive progress in science and industry.

Contact

Address: 3281 E Guasti Rd
Ontario, CA 91761, United States
Phone: (601) 213-4426
Email: info@benchchem.com

[Contact our Ph.D. Support Team for a compatibility check](#)