

In-depth Technical Guide: Biophysical Characterization of Teslexivir-Protein Interaction

Author: BenchChem Technical Support Team. **Date:** April 2026

Compound of Interest

Compound Name: *Teslexivir hydrochloride*

Cat. No.: *B10831840*

[Get Quote](#)

Audience: Researchers, scientists, and drug development professionals.

Introduction

Teslexivir is an antiviral agent that has been investigated for the treatment of infections caused by the Human Papillomavirus (HPV). It functions as an inhibitor of a critical protein-protein interaction essential for viral replication. This technical guide provides an in-depth overview of the biophysical characterization of the interaction between Teslexivir and its protein targets, the HPV E1 and E2 proteins. The document will detail the mechanism of action, present quantitative biophysical data, and provide detailed experimental protocols for key analytical techniques. Visualizations of signaling pathways and experimental workflows are included to facilitate understanding.

Mechanism of Action of Teslexivir

Teslexivir targets the protein-protein interaction between the HPV E1 and E2 proteins. E1 is a DNA helicase that unwinds the viral DNA, a crucial step for replication, while E2 is a multifunctional protein that, in addition to its transcriptional regulation roles, is responsible for recruiting E1 to the viral origin of replication. The formation of the E1-E2 complex is therefore a prerequisite for the initiation of HPV DNA replication. Teslexivir, an indandione derivative, binds

to the transactivation domain (TAD) of the E2 protein, at the interface where E1 normally binds. This binding event physically blocks the association of E1 with E2, thereby preventing the formation of the E1-E2 complex and halting viral DNA replication.

Below is a diagram illustrating the mechanism of action of Teslexivir.

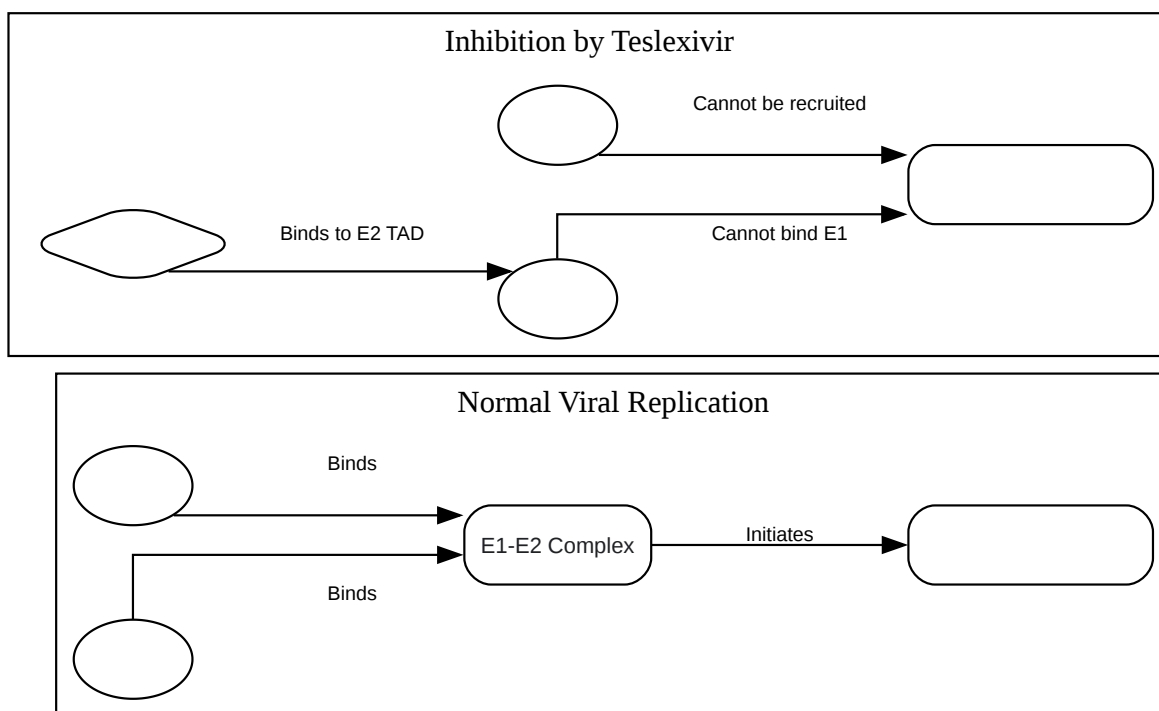

[Click to download full resolution via product page](#)

Caption: Mechanism of Teslexivir action.

Quantitative Data Presentation

The following tables summarize the biophysical data for inhibitors of the HPV E1-E2 interaction, including compounds from the same class as Teslexivir.

Table 1: Thermodynamic Parameters of Indandione Inhibitor Binding to HPV11 E2 TAD

Parameter	Value	Technique	Reference
Association Constant (Ka)	2.5 x 10 ⁷ M ⁻¹	ITC	[1]
Dissociation Constant (Kd)	40 nM	ITC	[1]
Enthalpy (ΔH)	-6.88 kcal/mol	ITC	[1]
Entropy ($T\Delta S$)	3.1 kcal/mol	ITC	[1]
Stoichiometry (n)	0.97	ITC	[1]

Table 2: In Vitro and Cellular Activity of Optimized E1-E2 Inhibitors

Compound Series	E1-E2 Interaction Inhibition (IC ₅₀)	Cellular DNA Replication Inhibition (EC ₅₀)	Reference
Indandione	Low nanomolar	~1 μ M	[2]
Repaglinide Analog	Low nanomolar	~1 μ M	[2]

Experimental Protocols

This section provides detailed methodologies for key biophysical experiments used to characterize the Teslexivir-protein interaction.

Isothermal Titration Calorimetry (ITC)

ITC directly measures the heat released or absorbed during a binding event, allowing for the determination of binding affinity (Kd), stoichiometry (n), and the thermodynamic parameters of enthalpy (ΔH) and entropy (ΔS).

Experimental Workflow:

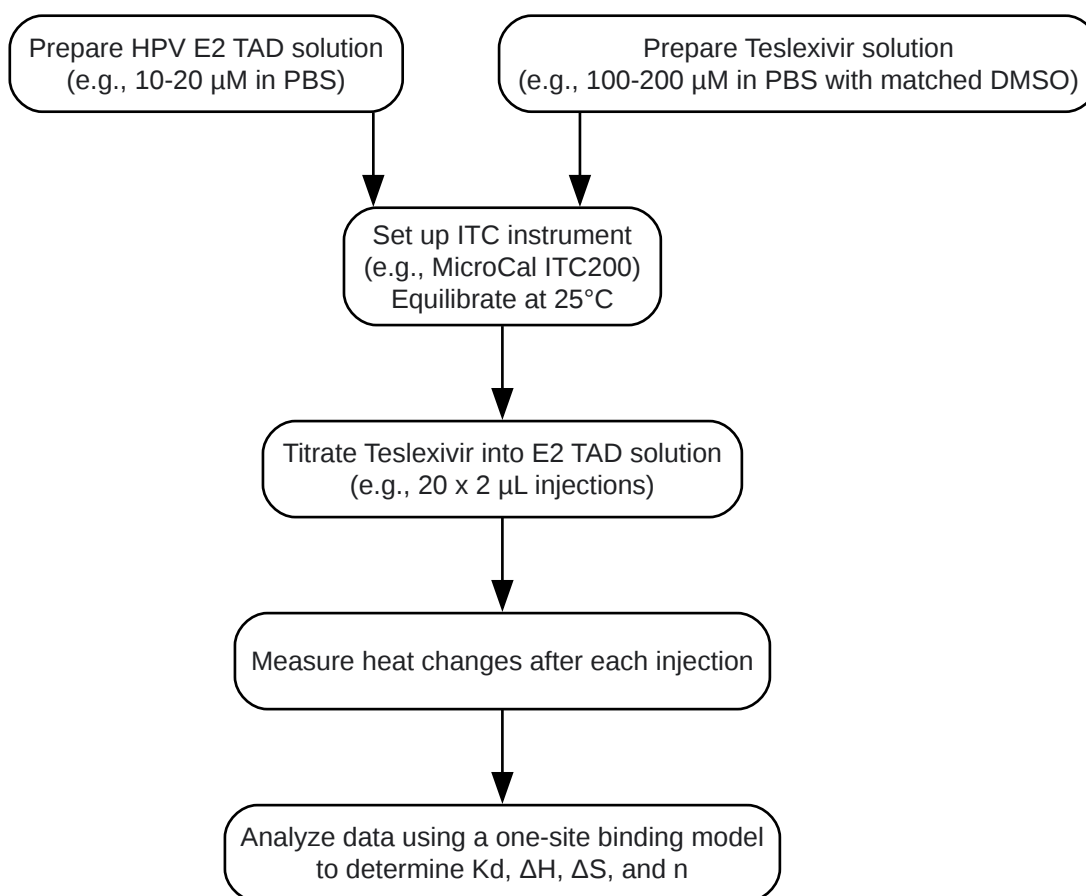

[Click to download full resolution via product page](#)

Caption: Isothermal Titration Calorimetry workflow.

Detailed Protocol:

- Protein and Ligand Preparation:
 - Express and purify the HPV11 E2 transactivation domain (TAD) (amino acids 1-205).
 - Dialyze the purified E2 TAD extensively against the ITC buffer (e.g., Phosphate-Buffered Saline (PBS), pH 7.4).
 - Prepare a stock solution of Teslexivir in 100% DMSO.
 - Dilute the Teslexivir stock solution into the same ITC buffer to the desired final concentration (e.g., 100-200 μM), ensuring the final DMSO concentration is matched in the protein solution (typically $\leq 5\%$).

- Prepare the E2 TAD solution to the desired concentration (e.g., 10-20 μM) in the ITC buffer containing the same final DMSO concentration as the Teslexivir solution.
- Degas both solutions immediately before the experiment.
- ITC Experiment:
 - Set the experimental temperature to 25°C.
 - Load the E2 TAD solution into the sample cell and the Teslexivir solution into the injection syringe.
 - Perform an initial injection of 0.4 μL , followed by a series of 19 injections of 2 μL each, with a spacing of 150 seconds between injections.
 - Record the heat changes upon each injection.
- Data Analysis:
 - Integrate the raw data to obtain the heat change per injection.
 - Fit the integrated data to a one-site binding model using the instrument's analysis software to determine the binding affinity (K_d), enthalpy (ΔH), and stoichiometry (n).
 - Calculate the Gibbs free energy (ΔG) and entropy (ΔS) from the fitted parameters using the equation: $\Delta G = -RT\ln(K_a) = \Delta H - T\Delta S$.

Surface Plasmon Resonance (SPR)

SPR is a label-free technique for real-time monitoring of biomolecular interactions. It provides kinetic information, including the association rate constant (k_a) and the dissociation rate constant (k_d), from which the equilibrium dissociation constant (K_d) can be calculated.

Experimental Workflow:

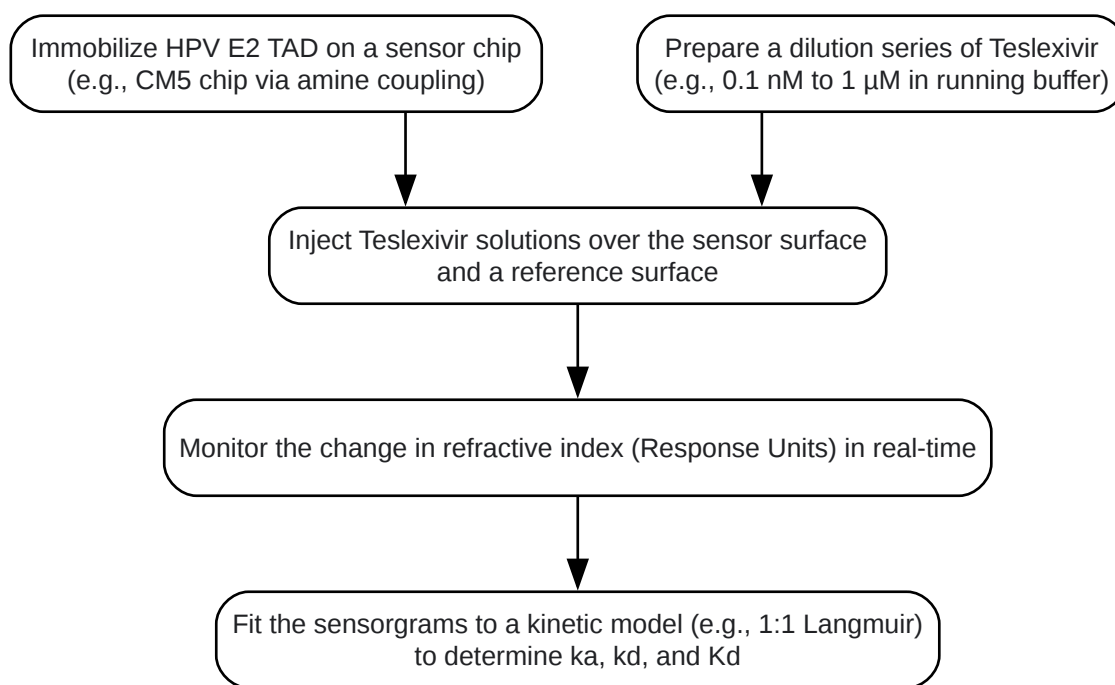

[Click to download full resolution via product page](#)

Caption: Surface Plasmon Resonance workflow.

Detailed Protocol:

- Immobilization of E2 TAD:
 - Activate the surface of a CM5 sensor chip with a 1:1 mixture of 0.4 M EDC and 0.1 M NHS.
 - Inject the purified E2 TAD (e.g., 50 μg/mL in 10 mM sodium acetate, pH 5.0) over the activated surface to achieve the desired immobilization level (e.g., ~2000 RU).
 - Deactivate the remaining active esters with an injection of 1 M ethanolamine-HCl, pH 8.5.
 - A reference flow cell should be prepared similarly but without the protein immobilization.
- Kinetic Analysis:
 - Prepare a series of Teslexivir concentrations (e.g., ranging from 0.1 nM to 1 μM) in a suitable running buffer (e.g., HBS-EP+ with 1% DMSO).

- Inject the Teslexivir solutions over the E2 TAD and reference surfaces at a constant flow rate (e.g., 30 $\mu\text{L}/\text{min}$) for a defined association time (e.g., 180 seconds), followed by a dissociation phase with running buffer.
- Regenerate the sensor surface between each concentration with a pulse of a mild regeneration solution (e.g., 10 mM glycine-HCl, pH 2.5) if necessary.
- Data Analysis:
 - Subtract the reference flow cell data from the active flow cell data to obtain specific binding sensorgrams.
 - Fit the sensorgrams globally to a suitable kinetic model (e.g., 1:1 Langmuir binding model) using the instrument's software to determine the association rate constant (k_a), dissociation rate constant (k_d), and the equilibrium dissociation constant (K_d).

X-Ray Crystallography

X-ray crystallography provides high-resolution structural information of the protein-ligand complex, revealing the precise binding mode of the inhibitor and the conformational changes in the protein upon binding.

Experimental Workflow:

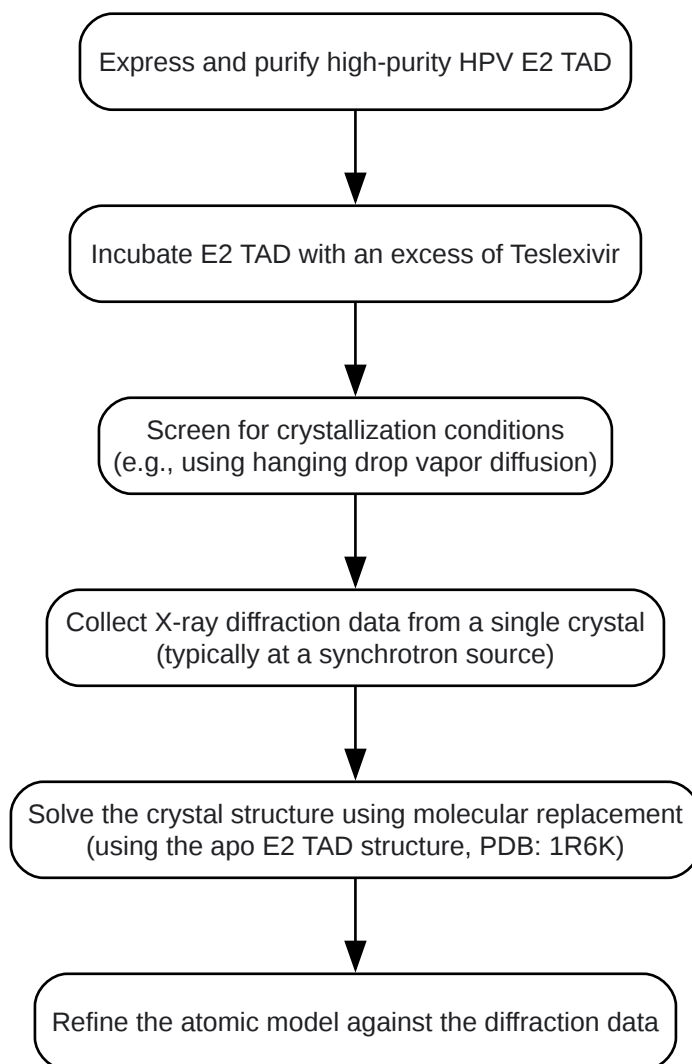

[Click to download full resolution via product page](#)

Caption: X-ray Crystallography workflow.

Detailed Protocol:

- Protein-Ligand Complex Preparation:
 - Concentrate the purified HPV11 E2 TAD to approximately 10 mg/mL.
 - Incubate the protein with a 3-fold molar excess of Teslexivir (dissolved in a minimal amount of DMSO and then diluted in the protein buffer) for 1 hour on ice.
- Crystallization:

- Set up crystallization trials using the hanging drop vapor diffusion method at 20°C.
- Mix 1 μ L of the protein-ligand complex with 1 μ L of the reservoir solution.
- A typical crystallization condition for the E2 TAD-inhibitor complex is 0.1 M MES pH 6.5, 0.2 M ammonium sulfate, and 30% w/v PEG 5000 MME.
- Data Collection and Structure Determination:
 - Cryo-protect the crystals by briefly soaking them in the reservoir solution supplemented with 20% glycerol before flash-cooling in liquid nitrogen.
 - Collect X-ray diffraction data at a synchrotron source.
 - Process the diffraction data using software such as XDS or HKL2000.
 - Solve the structure by molecular replacement using the coordinates of the apo E2 TAD (PDB ID: 1R6K) as a search model.
 - Build the model of the complex into the electron density map and refine the structure using software such as PHENIX or REFMAC5. The final structure of a similar complex is available under PDB ID: 1R6N.[3]

Mandatory Visualizations

Signaling Pathway of HPV Replication Inhibition

The following diagram illustrates the central role of the E1-E2 interaction in HPV DNA replication and how Teslexivir disrupts this pathway.

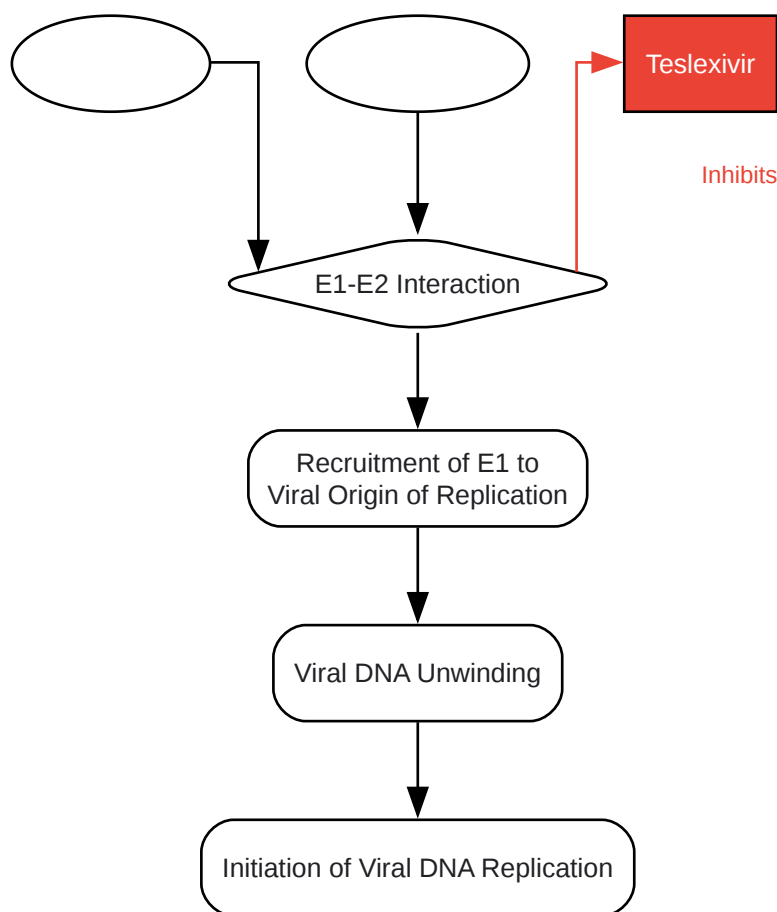

[Click to download full resolution via product page](#)

Caption: HPV replication pathway and Teslexivir inhibition.

Logical Relationship of Biophysical Techniques

The following diagram shows the logical flow and complementary nature of the described biophysical techniques in the characterization of a protein-ligand interaction.

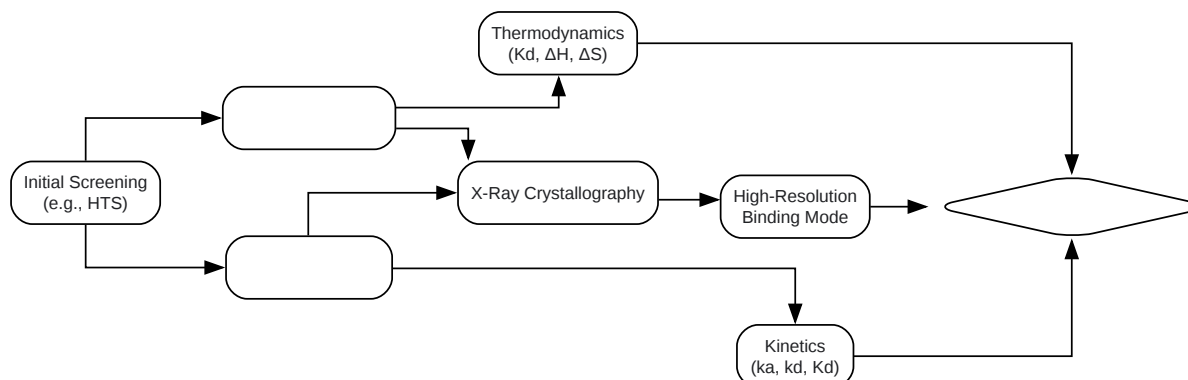

[Click to download full resolution via product page](#)

Caption: Interrelation of biophysical techniques.

Need Custom Synthesis?

BenchChem offers custom synthesis for rare earth carbides and specific isotopic labeling.

Email: info@benchchem.com or [Request Quote Online](#).

References

- [1. researchgate.net \[researchgate.net\]](https://www.researchgate.net)
- [2. Small molecule inhibitors of the human papillomavirus E1-E2 interaction - PubMed \[pubmed.ncbi.nlm.nih.gov\]](https://pubmed.ncbi.nlm.nih.gov/)
- [3. The X-ray structure of the papillomavirus helicase in complex with its molecular matchmaker E2 - PMC \[pmc.ncbi.nlm.nih.gov\]](https://pmc.ncbi.nlm.nih.gov/)
- To cite this document: BenchChem. [In-depth Technical Guide: Biophysical Characterization of Teslexivir-Protein Interaction]. BenchChem, [2026]. [Online PDF]. Available at: [\[https://www.benchchem.com/product/b10831840/docs#in-depth-technical-guide-biophysical-characterization-of-teslexivir-protein-interaction\]](https://www.benchchem.com/product/b10831840/docs#in-depth-technical-guide-biophysical-characterization-of-teslexivir-protein-interaction)

Disclaimer & Data Validity:

The information provided in this document is for Research Use Only (RUO) and is strictly not intended for diagnostic or therapeutic procedures. While BenchChem strives to provide accurate protocols, we make no warranties, express or implied, regarding the fitness of this product for every specific experimental setup.

Technical Support: The protocols provided are for reference purposes. Unsure if this reagent suits your experiment?

Need Industrial/Bulk Grade? [Request Custom Synthesis Quote](#)

BenchChem

Our mission is to be the trusted global source of essential and advanced chemicals, empowering scientists and researchers to drive progress in science and industry.

Contact

Address: 3281 E Guasti Rd
Ontario, CA 91761, United States
Phone: (601) 213-4426
Email: info@benchchem.com

[Contact our Ph.D. Support Team for a compatibility check](#)