

Damulin B in Lung Cancer Research: A Technical Guide

Author: BenchChem Technical Support Team. **Date:** April 2026

Compound of Interest

Compound Name: *damulin B*
Cat. No.: *B10831588*

[Get Quote](#)

For Researchers, Scientists, and Drug Development Professionals

Introduction

Damulin B, a dammarane-type saponin isolated from steamed *Gynostemma pentaphyllum*, has emerged as a promising compound in pre-clinical lung cancer research. Studies have demonstrated its potent cytotoxic effects against human lung carcinoma cells, suggesting its potential as a therapeutic agent. This technical guide provides a comprehensive overview of the current research on **damulin B**, focusing on its mechanism of action, effects on key signaling pathways, and detailed experimental methodologies.

Mechanism of Action

Damulin B exerts its anti-cancer effects on lung cancer cells primarily through the induction of apoptosis, cell cycle arrest, and inhibition of cell migration and invasion.[1] It has shown greater susceptibility in human lung cancer cells compared to normal human fibroblasts.[1]

Cytotoxicity

Damulin B exhibits significant cytotoxic effects against non-small cell lung cancer (NSCLC) cell lines, including A549 and H1299.[2] The half-maximal inhibitory concentration (IC50) values highlight its potency.

| Cell Line | IC50 (µM) | Citation |
|-----------|-----------|----------|
| A549 | 21.9 | [2] |
| H1299 | 21.7 | [2] |

Induction of Apoptosis

Damulin B triggers programmed cell death in lung cancer cells through the activation of both the intrinsic and extrinsic apoptosis pathways.[1] This is evidenced by an increased rate of apoptosis, generation of reactive oxygen species (ROS), and a reduction in the mitochondrial membrane potential.[1]

| Cell Line | Treatment | Apoptosis Induction | Quantitative Data | Citation |
|-----------|------------------------|--------------------------|---------------------------------------------------------------|----------|
| A549 | Damulin B (20 µM, 24h) | Increased apoptosis rate | Specific percentage not available in the reviewed literature. | [1][2] |
| H1299 | Damulin B (24 µM, 24h) | Increased apoptosis rate | Specific percentage not available in the reviewed literature. | [1][2] |

Cell Cycle Arrest

Treatment with **damulin B** leads to cell cycle arrest at the G0/G1 phase in lung cancer cells.[1] [2] This blockage prevents the cells from entering the S phase, thereby inhibiting DNA replication and cell proliferation.

| Cell Line | Treatment | Effect on Cell Cycle | Quantitative Data | Citation |
|-----------|-----------------------------|----------------------|----------------------------------------------------------------------------------------------|----------|
| A549 | Damulin B (20 μ M, 24h) | G0/G1 phase arrest | Specific percentages for G0/G1, S, and G2/M phases not available in the reviewed literature. | [1][2] |
| H1299 | Damulin B (24 μ M, 24h) | G0/G1 phase arrest | Specific percentages for G0/G1, S, and G2/M phases not available in the reviewed literature. | [1][2] |

Inhibition of Migration and Metastasis

Damulin B has been shown to suppress the migratory and invasive capabilities of lung cancer cells.[1] This is achieved by downregulating the expression of matrix metalloproteinases (MMPs), enzymes crucial for the degradation of the extracellular matrix, a key step in metastasis.[1]

Signaling Pathways Modulated by Damulin B

Damulin B's anti-cancer activities are orchestrated through the modulation of several key signaling proteins.

Apoptosis Signaling Pathway

Damulin B promotes apoptosis by upregulating pro-apoptotic proteins and downregulating anti-apoptotic proteins.

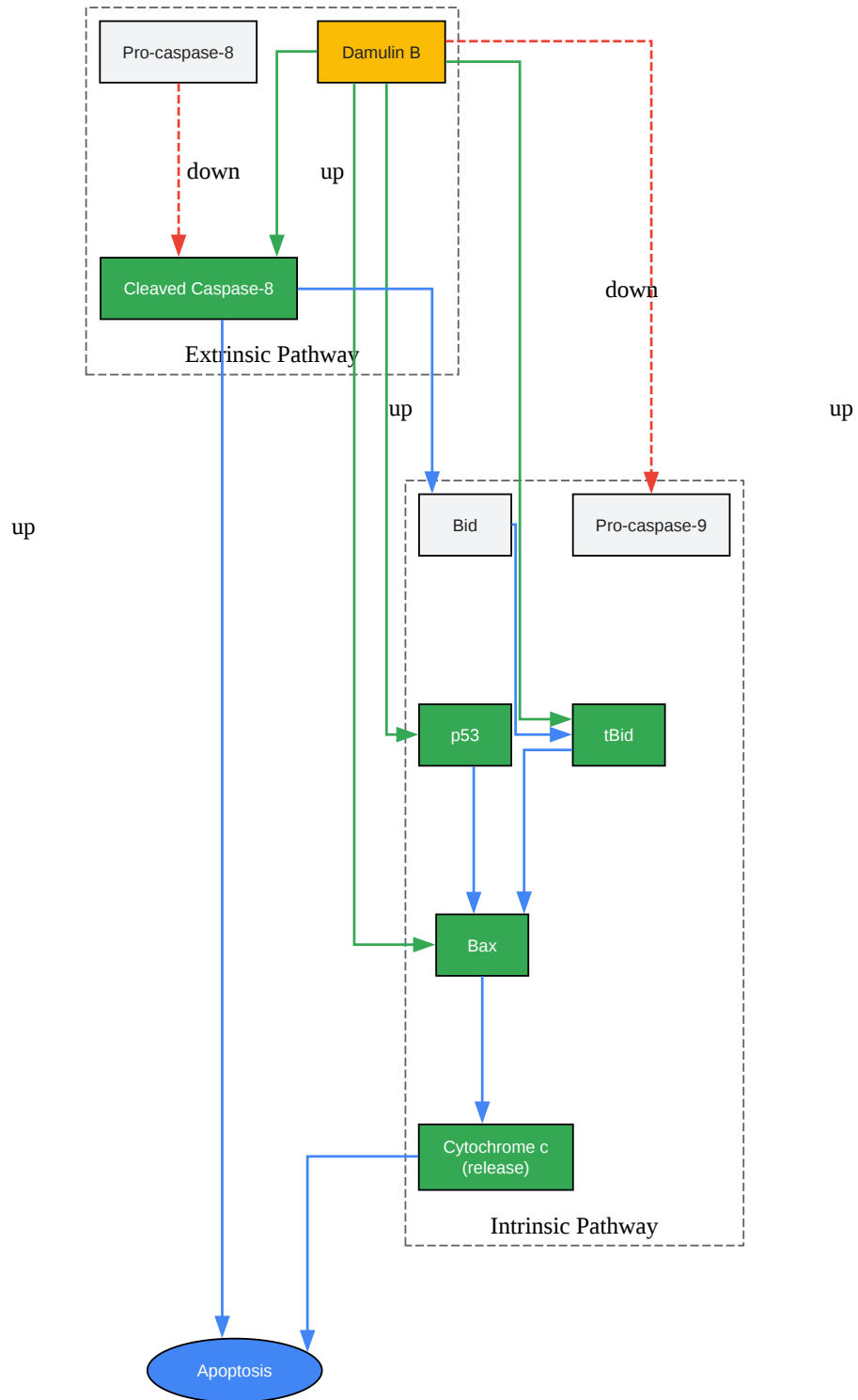

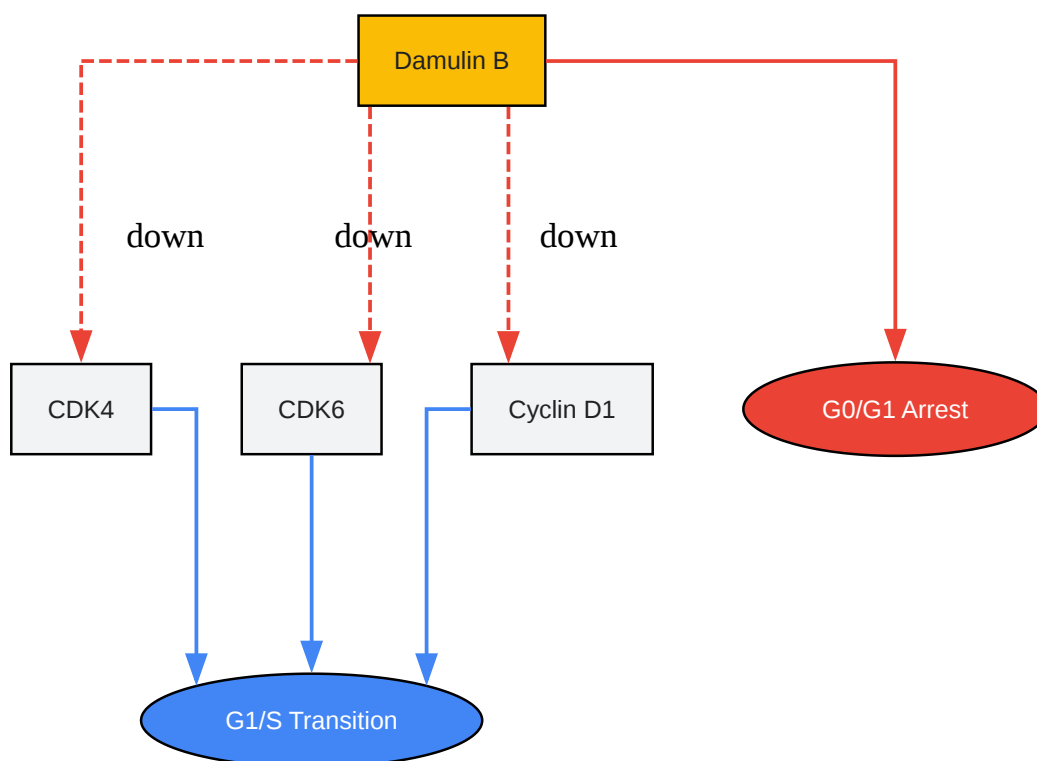

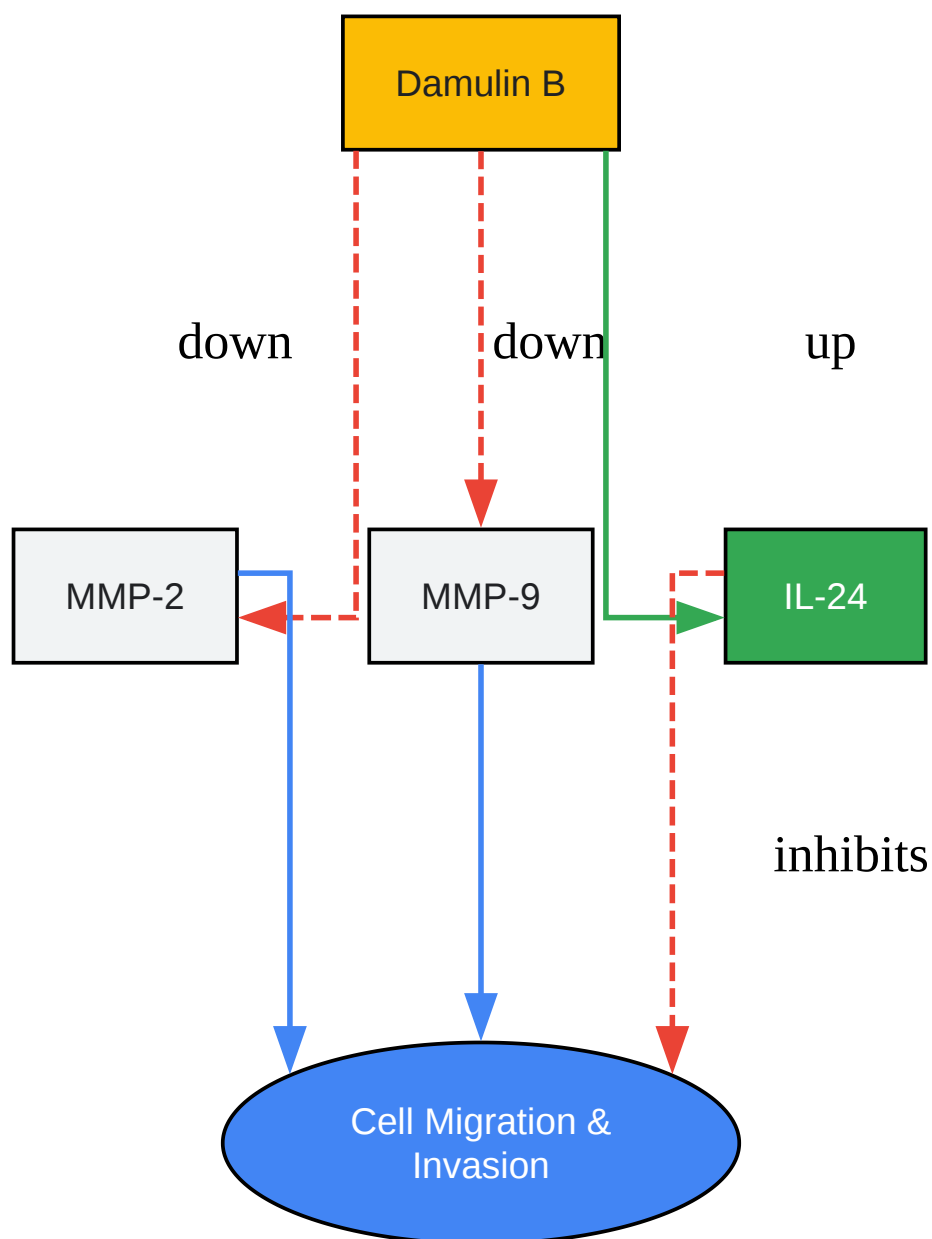

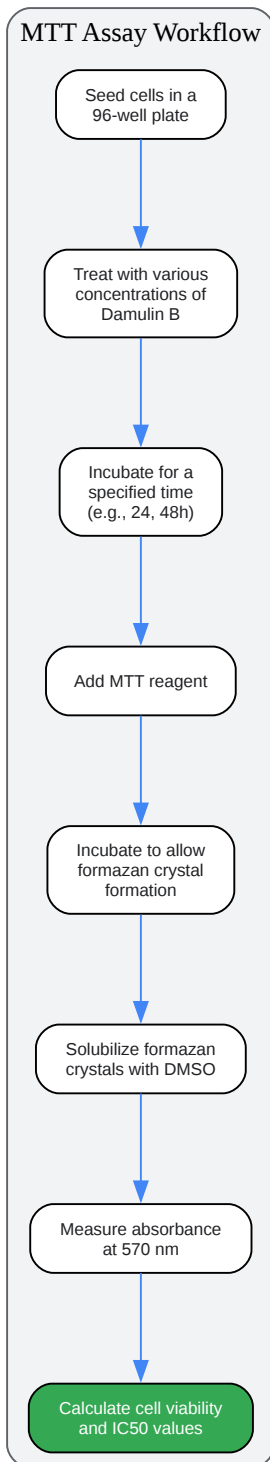
MTT Assay Workflow

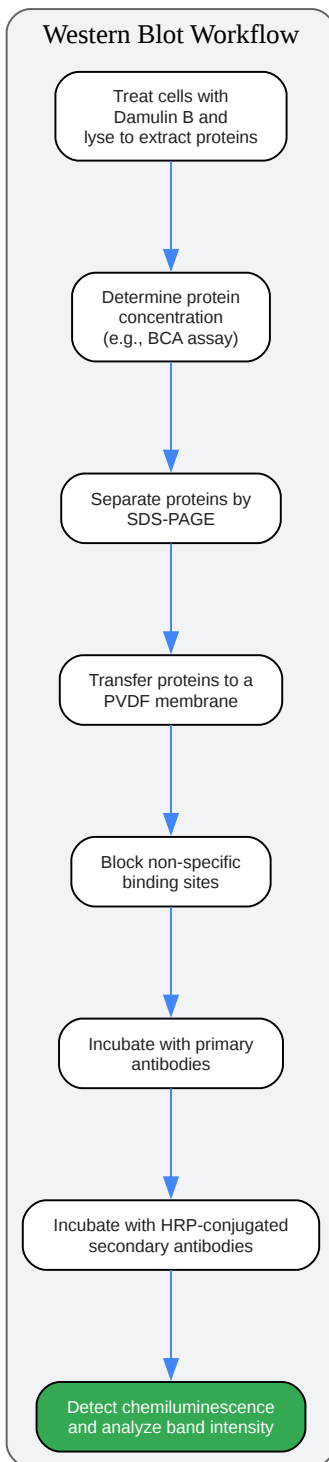

[Click to download full resolution via product page](#)

Need Custom Synthesis?

BenchChem offers custom synthesis for rare earth carbides and specific isotopic labeling.

Email: info@benchchem.com or [Request Quote Online](#).

References

- [1. Inhibitory Effect of Damulin B from Gynostemma pentaphyllum on Human Lung Cancer Cells - PubMed \[pubmed.ncbi.nlm.nih.gov\]](#)
- [2. file.medchemexpress.com \[file.medchemexpress.com\]](#)
- To cite this document: BenchChem. [Damulin B in Lung Cancer Research: A Technical Guide]. BenchChem, [2026]. [Online PDF]. Available at: [\[https://www.benchchem.com/product/b10831588/docs#damulin-b-in-lung-cancer-research-a-technical-guide\]](https://www.benchchem.com/product/b10831588/docs#damulin-b-in-lung-cancer-research-a-technical-guide)

Disclaimer & Data Validity:

The information provided in this document is for Research Use Only (RUO) and is strictly not intended for diagnostic or therapeutic procedures. While BenchChem strives to provide accurate protocols, we make no warranties, express or implied, regarding the fitness of this product for every specific experimental setup.

Technical Support: The protocols provided are for reference purposes. Unsure if this reagent suits your experiment?

Need Industrial/Bulk Grade? [Request Custom Synthesis Quote](#)

BenchChem

Our mission is to be the trusted global source of essential and advanced chemicals, empowering scientists and researchers to drive progress in science and industry.

Contact

Address: 3281 E Guasti Rd

Ontario, CA 91761, United States

Phone: (601) 213-4426

Email: info@benchchem.com

Contact our Ph.D. Support Team for a compatibility check