

Validating Lunresertib's Synthetic Lethal Partners: A Comparative Guide

Author: BenchChem Technical Support Team. **Date:** April 2026

Compound of Interest

Compound Name: Lunresertib
CAS No.: 2719793-90-3
Cat. No.: B10830186

[Get Quote](#)

For Researchers, Scientists, and Drug Development Professionals

This guide provides a comprehensive comparison of **Lunresertib**, a first-in-class oral small molecule inhibitor of Protein Kinase, Membrane Associated Tyrosine/Threonine 1 (PKMYT1), and its validated synthetic lethal partners. We will delve into the experimental data supporting its mechanism of action, particularly in combination with other targeted therapies, and compare its performance with alternative treatment strategies for specific, genetically defined cancers.

Introduction to Lunresertib and Synthetic Lethality

Lunresertib (also known as RP-6306) is a precision oncology agent developed by Repare Therapeutics.[1] Its therapeutic potential is rooted in the concept of synthetic lethality, a genetic interaction where the loss of two genes is lethal to a cell, but the loss of either gene alone is not.[2] **Lunresertib** exploits this by targeting PKMYT1 in cancer cells that have specific genetic alterations, namely amplification of the CCNE1 gene or deleterious mutations in FBXW7 or PPP2R1A.[3] These alterations, often found in aggressive and treatment-resistant cancers, create a dependency on PKMYT1 for cell survival, making them exquisitely sensitive to its inhibition.

PKMYT1 is a kinase that negatively regulates the G2/M cell cycle checkpoint by phosphorylating and inactivating Cyclin-Dependent Kinase 1 (CDK1).[4] Inhibition of PKMYT1 by **Lunresertib** leads to premature entry into mitosis, resulting in mitotic catastrophe and cell death, particularly in tumor cells with high levels of replication stress due to alterations like CCNE1 amplification.[5][6]

Validated Synthetic Lethal Partners of Lunresertib

The primary synthetic lethal partners of **Lunresertib** that have been validated in preclinical and clinical studies are:

- **CCNE1 Amplification:** Tumors with an abnormally high number of copies of the CCNE1 gene, which encodes for Cyclin E1, a key regulator of the cell cycle. This is a common alteration in several cancers, including ovarian and endometrial cancers, and is associated with poor prognosis and resistance to standard therapies.[7][8]
- **FBXW7 Deleterious Mutations:** Loss-of-function mutations in the FBXW7 gene, a tumor suppressor that targets Cyclin E1 for degradation.
- **PPP2R1A Deleterious Mutations:** Inactivating mutations in the PPP2R1A gene, which is also involved in cell cycle regulation.

These genetic alterations create a cellular state that is highly dependent on the PKMYT1-mediated checkpoint for survival, thus creating a therapeutic window for **Lunresertib**.

Experimental Validation and Clinical Data

The synthetic lethal interaction between **Lunresertib** and its partners has been extensively validated through a series of preclinical and clinical studies, most notably the Phase 1/2 MYTHIC clinical trial (NCT04855656).[9]

Preclinical Validation

Preclinical studies demonstrated that **Lunresertib** selectively inhibits the proliferation of cancer cell lines with CCNE1 amplification or FBXW7/PPP2R1A mutations.[5] These studies employed a range of experimental techniques to validate the mechanism of action:

- Cell Viability Assays: Demonstrated the potent and selective killing of cancer cells with the target genetic alterations upon treatment with **Lunresertib**.
- Pharmacodynamic (PD) Biomarker Analysis: Confirmed target engagement and downstream effects of PKMYT1 inhibition. This included:
 - Measurement of CDK1 phosphorylation: Inhibition of PKMYT1 leads to a decrease in the inhibitory phosphorylation of CDK1 at Threonine-14 and Tyrosine-15. This can be assessed by Western blotting or immunohistochemistry (IHC) using phospho-specific antibodies.
 - Assessment of DNA damage: The premature entry into mitosis caused by **Lunresertib** leads to an accumulation of DNA damage. This is often quantified by measuring the levels of phosphorylated histone H2AX (γ -H2AX) through immunofluorescence or flow cytometry. [\[10\]](#)
- Xenograft Models: In vivo studies using animal models bearing tumors with the relevant genetic alterations showed significant tumor growth inhibition and regression upon treatment with **Lunresertib**.

Clinical Validation: The MYTHIC Trial

The MYTHIC trial is a multi-cohort study evaluating **Lunresertib** as a monotherapy and in combination with other agents in patients with advanced solid tumors harboring CCNE1 amplification or FBXW7/PPP2R1A mutations.[\[9\]](#) The most promising results to date have emerged from the combination of **Lunresertib** with Camonsertib (RP-3500), an inhibitor of Ataxia Telangiectasia and Rad3-related (ATR) kinase, a key player in the DNA damage response (DDR) pathway.

Table 1: Key Efficacy Data from the MYTHIC Trial (**Lunresertib** + Camonsertib Combination)

Cancer Type	Patient Population	Overall Response Rate (ORR)	Clinical Benefit Rate (CBR)	Progression-Free Survival (PFS) at 24 weeks
Endometrial Cancer	Heavily pretreated, with Lunresertib-sensitizing biomarkers	25.9%	48.1%	43%
Platinum-Resistant Ovarian Cancer (PROC)	Heavily pretreated, with Lunresertib-sensitizing biomarkers	37.5%	79%	45%

Data as of November 14, 2024, from the gynecologic cancer expansion cohort.[\[9\]](#)

These results are particularly significant given the poor prognosis and limited treatment options for patients with platinum-resistant ovarian cancer and advanced endometrial cancer.[\[11\]](#)[\[12\]](#)

Comparison with Alternative Therapies

The therapeutic landscape for cancers with CCNE1 amplification or FBXW7/PPP2R1A mutations is evolving. Here, we compare the **Lunresertib** combination strategy with other potential therapeutic approaches.

Standard of Care for Platinum-Resistant Ovarian Cancer (PROC)

The current standard of care for PROC typically involves single-agent chemotherapy (e.g., paclitaxel, topotecan, pegylated liposomal doxorubicin) or bevacizumab.[\[13\]](#) These therapies generally have modest response rates, typically in the range of 10-20%, and short durations of response. The ORR of 37.5% observed with the **Lunresertib** and Camonsertib combination in PROC patients represents a potentially significant improvement over existing options.

Other Investigational Therapies for CCNE1-Amplified Cancers

- **CDK2 Inhibitors:** Given that Cyclin E1's primary function is to activate CDK2, inhibitors of CDK2 have been a logical therapeutic strategy. However, the development of selective and well-tolerated CDK2 inhibitors has been challenging.[7]
- **WEE1 Inhibitors:** WEE1 is another kinase that, like PKMYT1, inhibits CDK1. WEE1 inhibitors, such as Debio 0123 (zedoresertib), are also being investigated in combination with **Lunresertib** in a separate arm of the MYTHIC trial.[14][15][16] The rationale is that dual inhibition of PKMYT1 and WEE1 could lead to a more profound and sustained activation of CDK1, further enhancing the synthetic lethal effect.
- **mTOR Inhibitors:** Some preclinical and early clinical data suggest that mTOR inhibitors may have activity in CCNE1-amplified tumors by downregulating the homologous recombination DNA repair pathway, potentially sensitizing them to PARP inhibitors.[17]

Table 2: Comparison of **Lunresertib** Combination Therapy with Other Approaches

Therapeutic Strategy	Mechanism of Action	Key Advantages	Key Challenges
Lunresertib + Camonsertib (ATR inhibitor)	Dual targeting of cell cycle checkpoint (PKMYT1) and DNA damage response (ATR)	High response rates in heavily pretreated populations; chemotherapy-free regimen	Management of potential overlapping toxicities (e.g., anemia)
Lunresertib + Debio 0123 (WEE1 inhibitor)	Dual inhibition of CDK1 negative regulators	Potential for enhanced CDK1 activation and synthetic lethality	Data is still emerging from clinical trials
CDK2 Inhibitors	Direct inhibition of the oncogenic driver kinase	Theoretically a very direct approach	Development of selective and well-tolerated agents has been difficult
mTOR Inhibitors +/- PARP inhibitors	Downregulation of DNA repair pathways	Potential to sensitize tumors to other agents	Efficacy in CCNE1-amplified tumors is still under investigation
Standard Chemotherapy	Cytotoxic agents	Established treatment paradigm	Low response rates and significant toxicity in resistant disease

Experimental Protocols

Detailed protocols for the key assays used in the validation of **Lunresertib's** synthetic lethal partners are crucial for reproducibility and further research.

Pharmacodynamic Assays in the MYTHIC Trial

While specific, detailed protocols from the MYTHIC trial are proprietary, the general methodologies for the key pharmacodynamic assays are as follows:

Immunohistochemistry (IHC) for Phospho-CDK1 (pCDK1)

- Tissue Preparation: Formalin-fixed, paraffin-embedded (FFPE) tumor biopsy sections are deparaffinized and rehydrated.
- Antigen Retrieval: Heat-induced epitope retrieval is performed using a citrate-based buffer (pH 6.0).
- Blocking: Non-specific antibody binding is blocked using a serum-based blocking solution.
- Primary Antibody Incubation: Sections are incubated with a primary antibody specific for CDK1 phosphorylated at its inhibitory sites (e.g., Tyr15).
- Secondary Antibody and Detection: A horseradish peroxidase (HRP)-conjugated secondary antibody is applied, followed by a chromogenic substrate (e.g., DAB) to visualize the signal.
- Counterstaining and Mounting: Sections are counterstained with hematoxylin and mounted for microscopic analysis.
- Analysis: The intensity and localization of the pCDK1 signal are quantified. A decrease in signal in post-treatment biopsies compared to baseline indicates target engagement by **Lunresertib**.

γ -H2AX Immunofluorescence Assay for DNA Damage

- Cell/Tissue Preparation: Cells are cultured on coverslips or FFPE tissue sections are prepared as for IHC.
- Fixation and Permeabilization: Cells are fixed with paraformaldehyde and permeabilized with a detergent-based buffer (e.g., Triton X-100).
- Blocking: Non-specific binding is blocked with a serum-containing solution.
- Primary Antibody Incubation: Samples are incubated with a primary antibody specific for γ -H2AX.
- Secondary Antibody Incubation: A fluorescently-labeled secondary antibody is applied.
- Counterstaining and Mounting: Nuclei are counterstained with DAPI, and the coverslips are mounted with an anti-fade mounting medium.

- Imaging and Analysis: Images are acquired using a fluorescence microscope or a high-content imaging system. The number and intensity of γ -H2AX foci per nucleus are quantified to assess the level of DNA damage.[\[18\]](#)[\[19\]](#)[\[20\]](#)

Visualizing the Pathways

To better understand the mechanism of action of **Lunresertib** and its synthetic lethal interactions, the following diagrams illustrate the key signaling pathways.

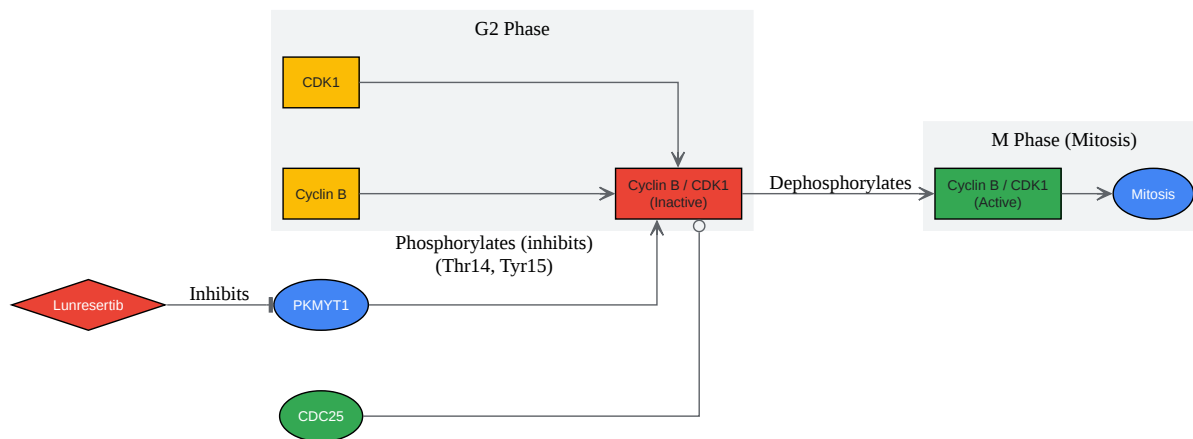

Tumor Cell with CCNE1 Amplification

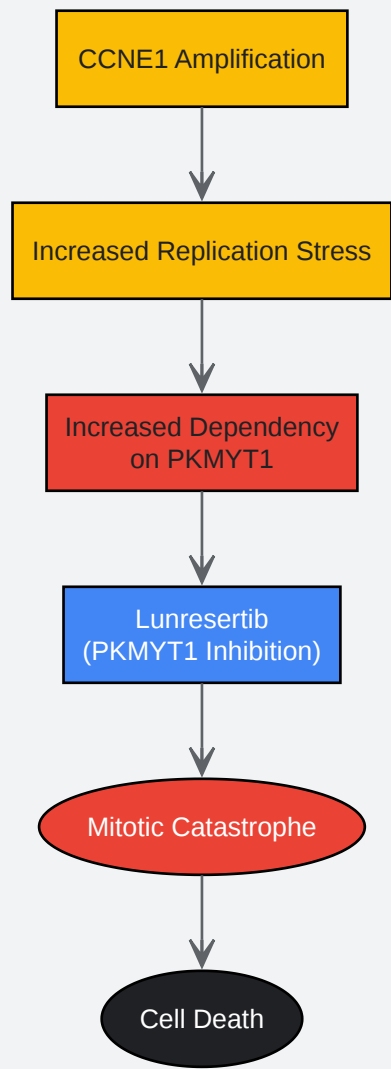

Normal Cell

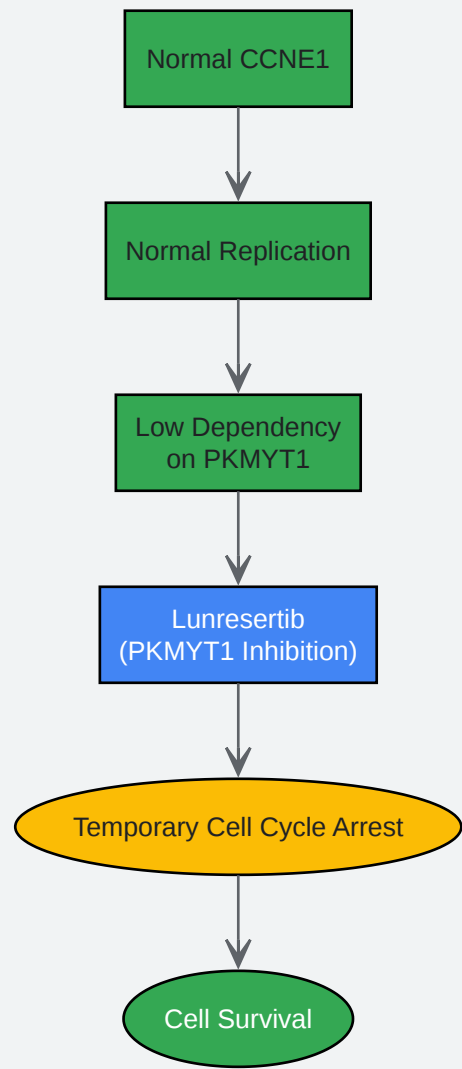

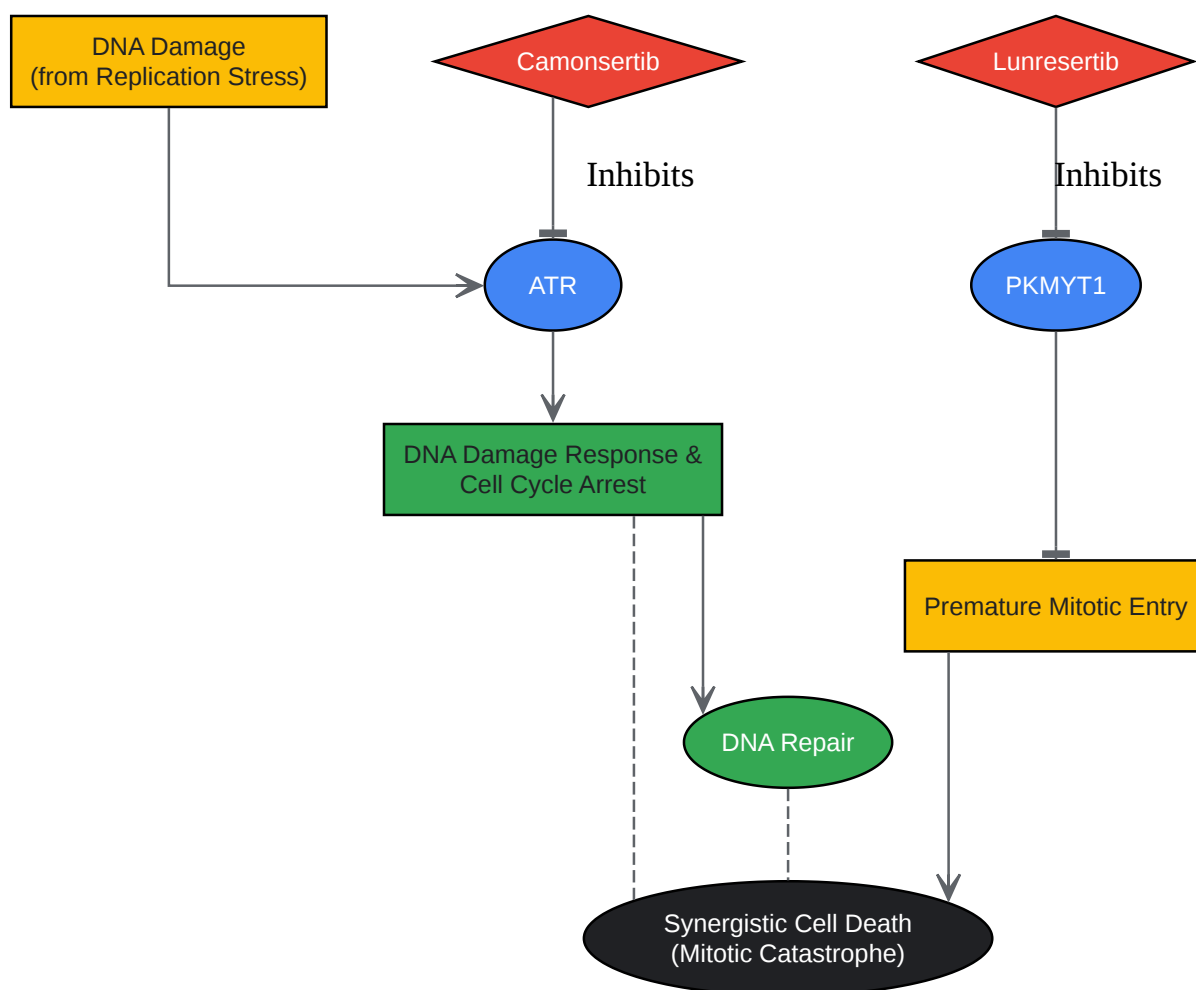

[Click to download full resolution via product page](#)

Need Custom Synthesis?

BenchChem offers custom synthesis for rare earth carbides and specific isotopic labeling.

Email: info@benchchem.com or [Request Quote Online](#).

References

- [1. ir.reparerx.com \[ir.reparerx.com\]](http://ir.reparerx.com)
- [2. researchgate.net \[researchgate.net\]](http://researchgate.net)
- [3. lunresertib \(Debio 2513\) - Debiopharm \[debiopharm.com\]](http://debiopharm.com)

- [4. researchgate.net \[researchgate.net\]](#)
- [5. aacrjournals.org \[aacrjournals.org\]](#)
- [6. apexbt.com \[apexbt.com\]](#)
- [7. CCNE1 Amplification as a Predictive Biomarker of Chemotherapy Resistance in Epithelial Ovarian Cancer - PMC \[pmc.ncbi.nlm.nih.gov\]](#)
- [8. Targeting CCNE1 amplified ovarian and endometrial cancers by combined inhibition of PKMYT1 and ATR - PMC \[pmc.ncbi.nlm.nih.gov\]](#)
- [9. ir.reparerx.com \[ir.reparerx.com\]](#)
- [10. USE OF THE \$\gamma\$ -H2AX ASSAY TO MONITOR DNA DAMAGE AND REPAIR IN TRANSLATIONAL CANCER RESEARCH - PMC \[pmc.ncbi.nlm.nih.gov\]](#)
- [11. ir.reparerx.com \[ir.reparerx.com\]](#)
- [12. Press Release Service: Repare Therapeutics Announces New Data Underscoring Need for Additional Treatment Solutions for Patients with Metastatic Gynecologic Cancers - CRISPR Medicine \[crisprmedicineneeds.com\]](#)
- [13. pharmacytimes.com \[pharmacytimes.com\]](#)
- [14. The WEE1 inhibitor Debio 0123 is synergistic with the PKMYT1 inhibitor lunresertib in preclinical models of ovarian and breast cancer - Debiopharm \[debiopharm.com\]](#)
- [15. debiopharm.com \[debiopharm.com\]](#)
- [16. zedoresertib \(Debio 0123\) - Debiopharm \[debiopharm.com\]](#)
- [17. Targeting therapeutic resistance and multinucleate giant cells in CCNE1-amplified HR-proficient ovarian cancer - PMC \[pmc.ncbi.nlm.nih.gov\]](#)
- [18. High-Throughput \$\gamma\$ -H2AX Assay Using Imaging Flow Cytometry | Springer Nature Experiments \[experiments.springernature.com\]](#)
- [19. academic.oup.com \[academic.oup.com\]](#)
- [20. Quantitative \$\gamma\$ -H2AX immunofluorescence method for DNA double-strand break analysis in testis and liver after intravenous administration of \$^{111}\text{InCl}_3\$ - PMC \[pmc.ncbi.nlm.nih.gov\]](#)
- To cite this document: BenchChem. [Validating Lunresertib's Synthetic Lethal Partners: A Comparative Guide]. BenchChem, [2026]. [Online PDF]. Available at: [\[https://www.benchchem.com/product/b10830186/docs#validating-lunresertib-s-synthetic-lethal-partners-a-comparative-guide\]](https://www.benchchem.com/product/b10830186/docs#validating-lunresertib-s-synthetic-lethal-partners-a-comparative-guide)

Disclaimer & Data Validity:

The information provided in this document is for Research Use Only (RUO) and is strictly not intended for diagnostic or therapeutic procedures. While BenchChem strives to provide accurate protocols, we make no warranties, express or implied, regarding the fitness of this product for every specific experimental setup.

Technical Support: The protocols provided are for reference purposes. Unsure if this reagent suits your experiment?

Need Industrial/Bulk Grade? [Request Custom Synthesis Quote](#)

BenchChem

Our mission is to be the trusted global source of essential and advanced chemicals, empowering scientists and researchers to drive progress in science and industry.

Contact

Address: 3281 E Guasti Rd
Ontario, CA 91761, United States
Phone: (601) 213-4426
Email: info@benchchem.com

[Contact our Ph.D. Support Team for a compatibility check](#)