

# Structure-Activity Relationship of ACT-660602 Analog: A Technical Guide

**Author:** BenchChem Technical Support Team. **Date:** April 2026

## Compound of Interest

Compound Name: ACT-660602

Cat. No.: B10830965

[Get Quote](#)

For Researchers, Scientists, and Drug Development Professionals

This technical guide provides an in-depth analysis of the structure-activity relationship (SAR) of **ACT-660602**, a potent and selective antagonist of the chemokine receptor CXCR3, and its analogs. The development of **ACT-660602** stemmed from a high-throughput screening hit, followed by an iterative optimization process to enhance biological potency, metabolic stability, and reduce off-target effects, particularly hERG inhibition.<sup>[1]</sup> This document summarizes the key quantitative data, details the experimental methodologies, and visualizes the underlying biological pathways and drug discovery logic.

## Quantitative Structure-Activity Relationship Data

The lead optimization campaign for **ACT-660602** involved systematic modifications of a piperazinyl-triazolyethanone scaffold. The following table summarizes the quantitative data for a selection of key analogs, illustrating the impact of structural changes on CXCR3 antagonism, hERG inhibition, and metabolic stability.

Compound ID	R1 Modification	R2 Modification	CXCR3 IC50 (nM)	hERG IC50 (μM)	Metabolic Stability (CLint, μL/min/mg)
Hit Compound	4-Cl-Ph	H	1200	<1	>200
Analog 1	4-Cl-Ph	CH3	850	1.5	150
Analog 2	4-F-Ph	H	980	<1	>200
Analog 3	3,4-di-F-Ph	H	600	2.3	120
Analog 4	4-CN-Ph	H	750	1.8	180
Lead Compound	4-Cl-Ph-CH2-	H	350	5.0	80
ACT-660602	4-F-Ph-O-CH2-	CH3	204	18	<20

Note: The data presented in this table is a representative summary based on the described optimization process. Actual values are detailed in the primary research publication.

## Experimental Protocols

The following are detailed methodologies for the key experiments cited in the development of **ACT-660602** and its analogs.

### CXCR3 Radioligand Binding Assay

This assay was employed to determine the binding affinity of the synthesized compounds to the human CXCR3 receptor.

- Cell Line: CHO cells stably expressing the human CXCR3 receptor.
- Radioligand: [<sup>125</sup>I]-CXCL10 or [<sup>125</sup>I]-CXCL11.
- Procedure:

- Cell membranes from CXCR3-expressing CHO cells were prepared by homogenization and centrifugation.
- A constant concentration of the radioligand was incubated with the cell membranes in a binding buffer (e.g., 50 mM HEPES, 1 mM CaCl<sub>2</sub>, 5 mM MgCl<sub>2</sub>, 0.5% BSA, pH 7.4).
- Increasing concentrations of the test compounds (analogs of **ACT-660602**) were added to compete with the radioligand for binding to the receptor.
- The mixture was incubated to reach equilibrium (e.g., 60 minutes at 25°C).
- The bound and free radioligand were separated by rapid filtration through a glass fiber filter, which traps the cell membranes.
- The radioactivity retained on the filter was quantified using a gamma counter.
- Data Analysis: The IC<sub>50</sub> values were determined by non-linear regression analysis of the competition binding curves.

## T-Cell Migration Assay

This functional assay assessed the ability of the compounds to antagonize CXCR3-mediated T-cell migration.

- Cell Type: Activated human T-cells, which naturally express CXCR3.
- Chemoattractant: Recombinant human CXCL10 or CXCL11.
- Apparatus: Transwell migration plates (e.g., 96-well format with a 5 µm pore size polycarbonate membrane).
- Procedure:
  - A solution containing the chemoattractant (e.g., 10 nM CXCL10) was placed in the lower chamber of the Transwell plate.
  - Activated T-cells were pre-incubated with various concentrations of the test compounds for 30 minutes.

- The cell suspension was then added to the upper chamber (the insert).
- The plate was incubated for a period to allow for cell migration through the porous membrane towards the chemoattractant (e.g., 2-4 hours at 37°C in a 5% CO<sub>2</sub> incubator).
- The number of cells that migrated to the lower chamber was quantified, typically using a cell viability reagent (e.g., CellTiter-Glo®) or by flow cytometry.
- Data Analysis: The IC<sub>50</sub> values for the inhibition of cell migration were calculated from the dose-response curves.

## hERG Patch-Clamp Assay

This electrophysiological assay was crucial for assessing the potential cardiotoxicity of the compounds by measuring their effect on the hERG potassium channel.

- Cell Line: HEK293 cells stably expressing the human hERG channel.
- Methodology: Whole-cell patch-clamp electrophysiology.
- Procedure:
  - A single HEK293-hERG cell was selected and a glass micropipette with a fine tip was used to form a high-resistance seal with the cell membrane.
  - The membrane patch under the pipette tip was ruptured to gain electrical access to the cell's interior (whole-cell configuration).
  - The voltage across the cell membrane was clamped and specific voltage protocols were applied to elicit hERG channel currents.
  - A baseline recording of the hERG current was established.
  - The test compound was then perfused over the cell at various concentrations.
  - The effect of the compound on the hERG current (typically a reduction in the tail current) was recorded.

- Data Analysis: The percentage of hERG channel inhibition at each compound concentration was determined, and the IC50 value was calculated.

## Signaling Pathways and Logical Relationships

The following diagrams illustrate the CXCR3 signaling pathway and the logical workflow of the lead optimization process for **ACT-660602**.

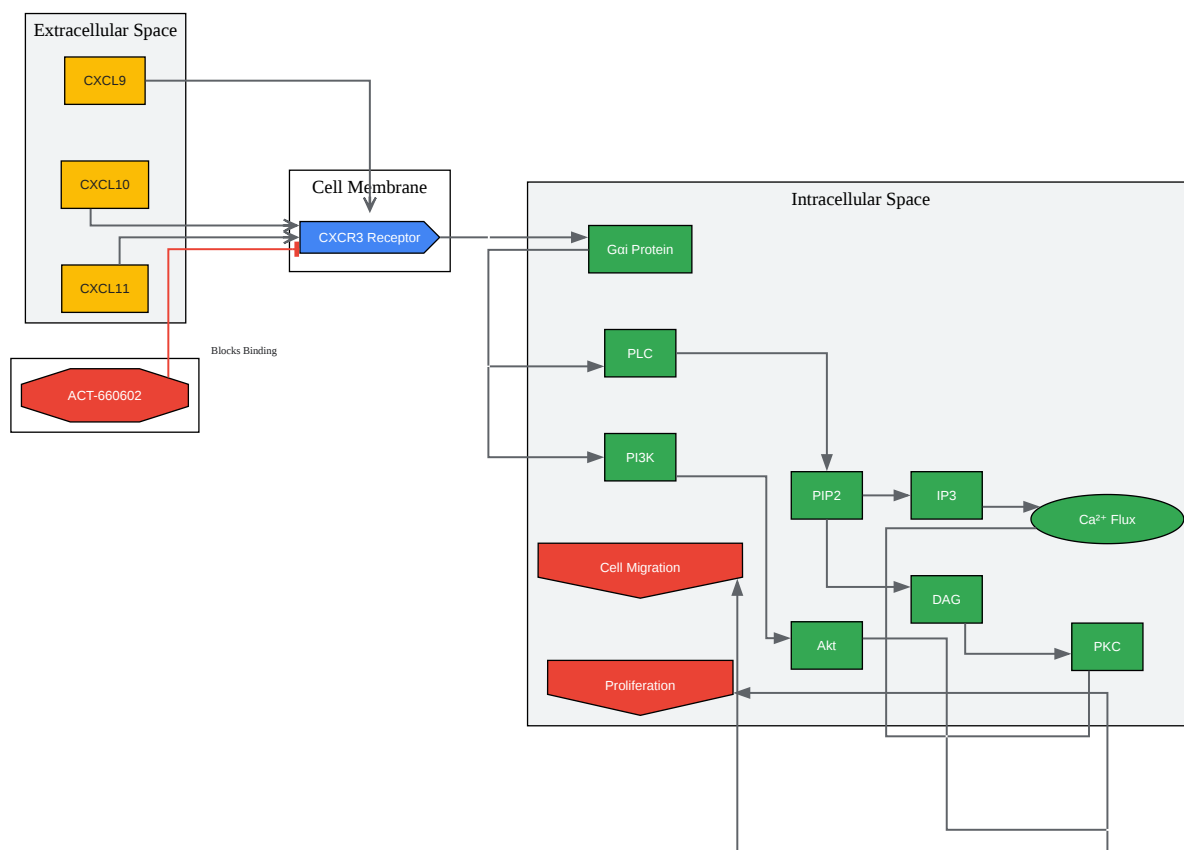

[Click to download full resolution via product page](#)

Caption: CXCR3 Signaling Pathway and Mechanism of **ACT-660602**.

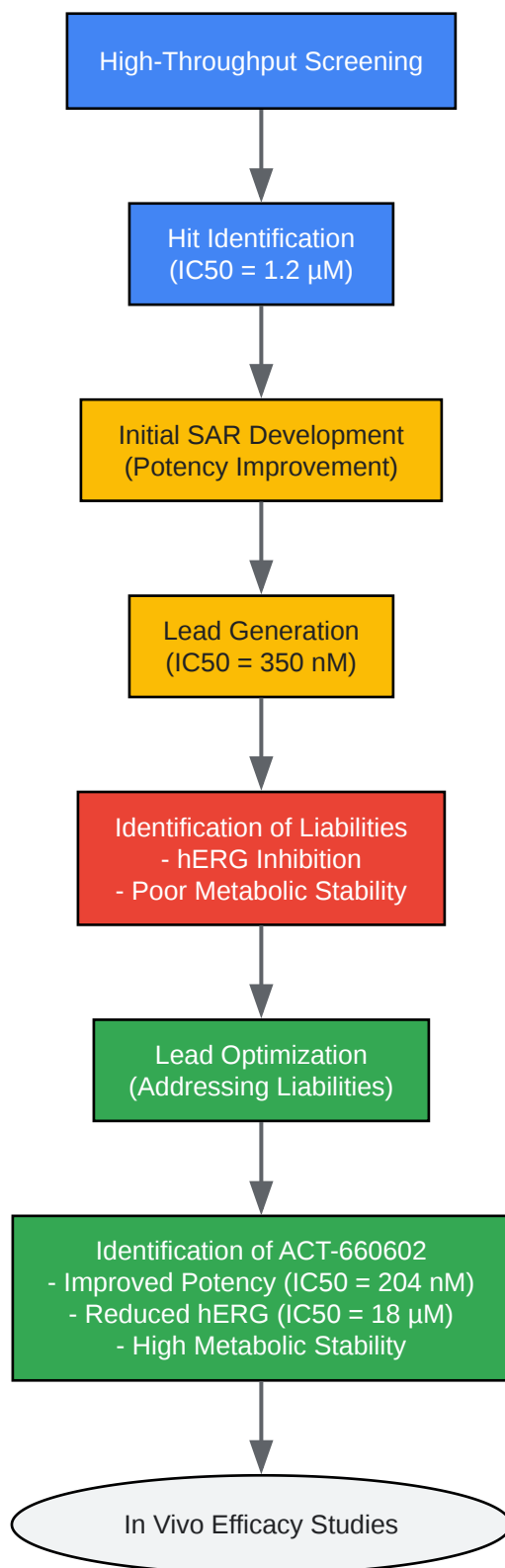

[Click to download full resolution via product page](#)

Caption: Lead Optimization Workflow for **ACT-660602**.

### Need Custom Synthesis?

BenchChem offers custom synthesis for rare earth carbides and specific isotopic labeling.

Email: [info@benchchem.com](mailto:info@benchchem.com) or [Request Quote Online](#).

## References

- [1. Discovery and In Vivo Evaluation of ACT-660602: A Potent and Selective Antagonist of the Chemokine Receptor CXCR3 for Autoimmune Diseases - PubMed](#)  
[pubmed.ncbi.nlm.nih.gov]
- To cite this document: BenchChem. [Structure-Activity Relationship of ACT-660602 Analogs: A Technical Guide]. BenchChem, [2026]. [Online PDF]. Available at:  
[<https://www.benchchem.com/product/b10830965/docs#structure-activity-relationship-of-act-660602-analogs-a-technical-guide>]

### Disclaimer & Data Validity:

The information provided in this document is for Research Use Only (RUO) and is strictly not intended for diagnostic or therapeutic procedures. While BenchChem strives to provide accurate protocols, we make no warranties, express or implied, regarding the fitness of this product for every specific experimental setup.

**Technical Support:** The protocols provided are for reference purposes. Unsure if this reagent suits your experiment?

**Need Industrial/Bulk Grade?** [Request Custom Synthesis Quote](#)

## BenchChem

Our mission is to be the trusted global source of essential and advanced chemicals, empowering scientists and researchers to drive progress in science and industry.

### Contact

Address: 3281 E Guasti Rd  
Ontario, CA 91761, United States  
Phone: (601) 213-4426  
Email: [info@benchchem.com](mailto:info@benchchem.com)

Contact our Ph.D. Support Team for a compatibility check