

Gp91 ds-tat Peptide Technical Support Center

Author: BenchChem Technical Support Team. **Date:** April 2026

Compound of Interest

Compound Name: Gp91 ds-tat

Cat. No.: B10830428

[Get Quote](#)

This technical support center provides researchers, scientists, and drug development professionals with comprehensive troubleshooting guides and frequently asked questions (FAQs) for the quality control of **Gp91 ds-tat** peptide.

Frequently Asked Questions (FAQs)

1. What is the **Gp91 ds-tat** peptide and what is its mechanism of action?

The **Gp91 ds-tat** peptide is a chimeric peptide composed of two functional domains: a sequence from gp91phox (also known as Nox2) and a cell-penetrating peptide sequence from the HIV-1 trans-activator of transcription (Tat).[1] The gp91phox sequence acts as a competitive inhibitor of the NADPH oxidase 2 (Nox2) enzyme complex assembly, specifically by mimicking the docking site for the p47phox subunit.[2][3] This prevents the formation of a functional enzyme complex, thereby inhibiting the production of superoxide radicals.[4][5] The Tat sequence facilitates the entry of the peptide into cells, allowing it to reach its intracellular target.[1][6]

2. What is the amino acid sequence and molecular weight of **Gp91 ds-tat**?

The typical amino acid sequence is H-Tyr-Gly-Arg-Lys-Lys-Arg-Arg-Gln-Arg-Arg-Arg-Cys-Ser-Thr-Arg-Ile-Arg-Arg-Gln-Leu-NH₂.[1] The corresponding molecular weight is approximately

2671.6 g/mol .[\[1\]](#) Some variants may exist, such as a version that is two amino acids shorter at the N-terminus.[\[6\]](#)[\[7\]](#)

3. How should the **Gp91 ds-tat** peptide be stored and handled?

For long-term storage, the lyophilized peptide powder should be stored at -20°C, where it can be stable for up to three years.[\[8\]](#) Once reconstituted in a solvent, it is recommended to aliquot the stock solution to avoid repeated freeze-thaw cycles.[\[8\]](#) Stock solutions can be stored at -80°C for up to a year or at -20°C for one month.[\[8\]](#)

4. How do I reconstitute the **Gp91 ds-tat** peptide?

The peptide is soluble in water.[\[8\]](#) For stock solutions, dissolve the peptide in sterile, nuclease-free water. To enhance solubility, you can gently vortex the solution or use an ultrasonic bath.[\[9\]](#)

5. What purity level should I expect for the **Gp91 ds-tat** peptide?

Reputable suppliers typically provide **Gp91 ds-tat** peptide with a purity of $\geq 95\%$ as determined by High-Performance Liquid Chromatography (HPLC).[\[10\]](#)[\[11\]](#) For sensitive applications, higher purities, such as $>98\%$, may be available.[\[4\]](#)

6. Why is it important to use a scrambled control peptide?

A scrambled control peptide, such as **sgp91 ds-tat**, consists of the same amino acids as the active peptide but in a random sequence.[\[5\]](#)[\[9\]](#)[\[12\]](#) This control is crucial to demonstrate that the observed biological effects are specific to the inhibitory sequence of **Gp91 ds-tat** and not due to non-specific effects of a cell-penetrating peptide or the presence of a peptide itself.[\[13\]](#)

Troubleshooting Guide

Issue	Possible Cause	Recommended Solution
Reduced or no inhibitory activity in my experiment.	Peptide Degradation: Improper storage or multiple freeze-thaw cycles of the stock solution can lead to peptide degradation.[8]	Always aliquot stock solutions after the first reconstitution and store them at the recommended temperatures (-20°C or -80°C).[8] Avoid repeated freeze-thaw cycles.
Incorrect Peptide Concentration: The effective concentration of the peptide can vary depending on the cell type and experimental conditions.	Perform a dose-response experiment to determine the optimal concentration for your specific model. Concentrations ranging from 1 µM to 50 µM have been reported in the literature.[4][13]	
Low Purity of the Peptide: Impurities in the peptide preparation can interfere with its activity or cause off-target effects.	Always use a high-purity peptide (≥95%). Verify the purity of your peptide batch using HPLC.[14]	
Cellular Uptake Issues: While the Tat sequence facilitates cell entry, uptake efficiency can vary between cell types.	Confirm cellular uptake using a fluorescently labeled version of the Gp91 ds-tat peptide, if available.	
Inconsistent results between experiments.	Batch-to-Batch Variability: There may be slight variations in purity or peptide content between different synthesis batches.	Always obtain a certificate of analysis (CoA) for each new batch.[8] Perform a validation experiment with each new batch to ensure consistent activity.
Inaccurate Peptide Quantification: The net peptide content of the lyophilized powder can be lower than the total weight due to the	For precise quantification, consider performing amino acid analysis or using a peptide quantification assay.	

presence of counter-ions and water.

Observed off-target effects or cellular toxicity.	Contaminants in the Peptide Preparation: Residual solvents from synthesis or other impurities could be causing toxicity.	Ensure the peptide is from a reputable source that performs thorough quality control for contaminants like endotoxins, especially for in vivo studies. [15]
---	--	---

High Peptide Concentration: Excessive concentrations of the peptide may lead to non-specific effects or toxicity.	Lower the concentration of the peptide used in your experiments and perform a toxicity assay.
---	---

Quantitative Data Summary

Table 1: Typical Quality Control Specifications for **Gp91 ds-tat** Peptide

Parameter	Method	Typical Specification
Purity	HPLC	≥95% [10] [11]
Identity	Mass Spectrometry	Matches the theoretical molecular weight (approx. 2673.3 Da) [11]
Appearance	Visual	White lyophilized powder
Solubility	Visual	Soluble in water [8]

Table 2: Recommended Concentration Ranges for **Gp91 ds-tat** Peptide in Different Applications

Application	Concentration Range	Reference
In vitro cell culture	1 μM - 50 μM	[4] [13]
In vivo (rodent models)	10 mg/kg	[13]

Experimental Protocols

Protocol 1: Purity Assessment by Reversed-Phase High-Performance Liquid Chromatography (RP-HPLC)

This protocol outlines a general procedure for determining the purity of the **Gp91 ds-tat** peptide.

1. Materials:

- **Gp91 ds-tat** peptide, lyophilized powder
- Mobile Phase A: 0.1% Trifluoroacetic acid (TFA) in HPLC-grade water
- Mobile Phase B: 0.1% Trifluoroacetic acid (TFA) in HPLC-grade acetonitrile
- C18 analytical HPLC column
- HPLC system with a UV detector

2. Procedure:

- Prepare a 1 mg/mL stock solution of the **Gp91 ds-tat** peptide in Mobile Phase A.
- Set up the HPLC system with the C18 column, equilibrated with 95% Mobile Phase A and 5% Mobile Phase B.
- Inject 10-20 μ L of the peptide solution.
- Run a linear gradient from 5% to 65% Mobile Phase B over 30 minutes at a flow rate of 1 mL/min.
- Monitor the elution profile at 214 nm or 280 nm.
- The purity is calculated as the area of the main peptide peak divided by the total area of all peaks in the chromatogram.^{[14][15]}

Protocol 2: Identity Verification by Mass Spectrometry (MS)

This protocol describes a general method to confirm the molecular weight of the **Gp91 ds-tat** peptide.

1. Materials:

- **Gp91 ds-tat** peptide solution (from HPLC or a separate preparation)
- Mass spectrometer (e.g., ESI-MS)

2. Procedure:

- Prepare a dilute solution of the peptide in an appropriate solvent (e.g., 50% acetonitrile with 0.1% formic acid).
- Infuse the sample directly into the mass spectrometer or analyze the eluent from an LC-MS system.
- Acquire the mass spectrum in the positive ion mode.
- The resulting spectrum will show a series of peaks corresponding to the peptide with different charge states (e.g., $[M+2H]^{2+}$, $[M+3H]^{3+}$, etc.).
- Deconvolute the spectrum to determine the molecular mass (M) of the peptide.
- Compare the experimentally determined molecular mass with the theoretical mass calculated from the amino acid sequence.[16][17][18]

Visualizations

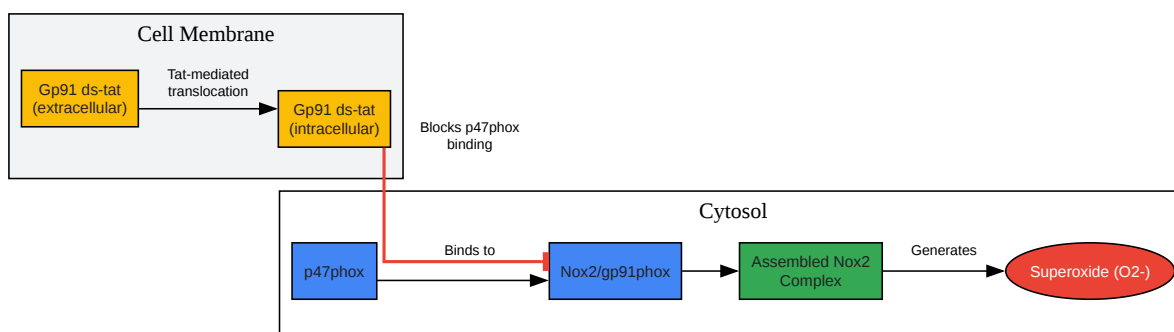

[Click to download full resolution via product page](#)

Caption: Mechanism of **Gp91 ds-tat** as a Nox2 inhibitor.

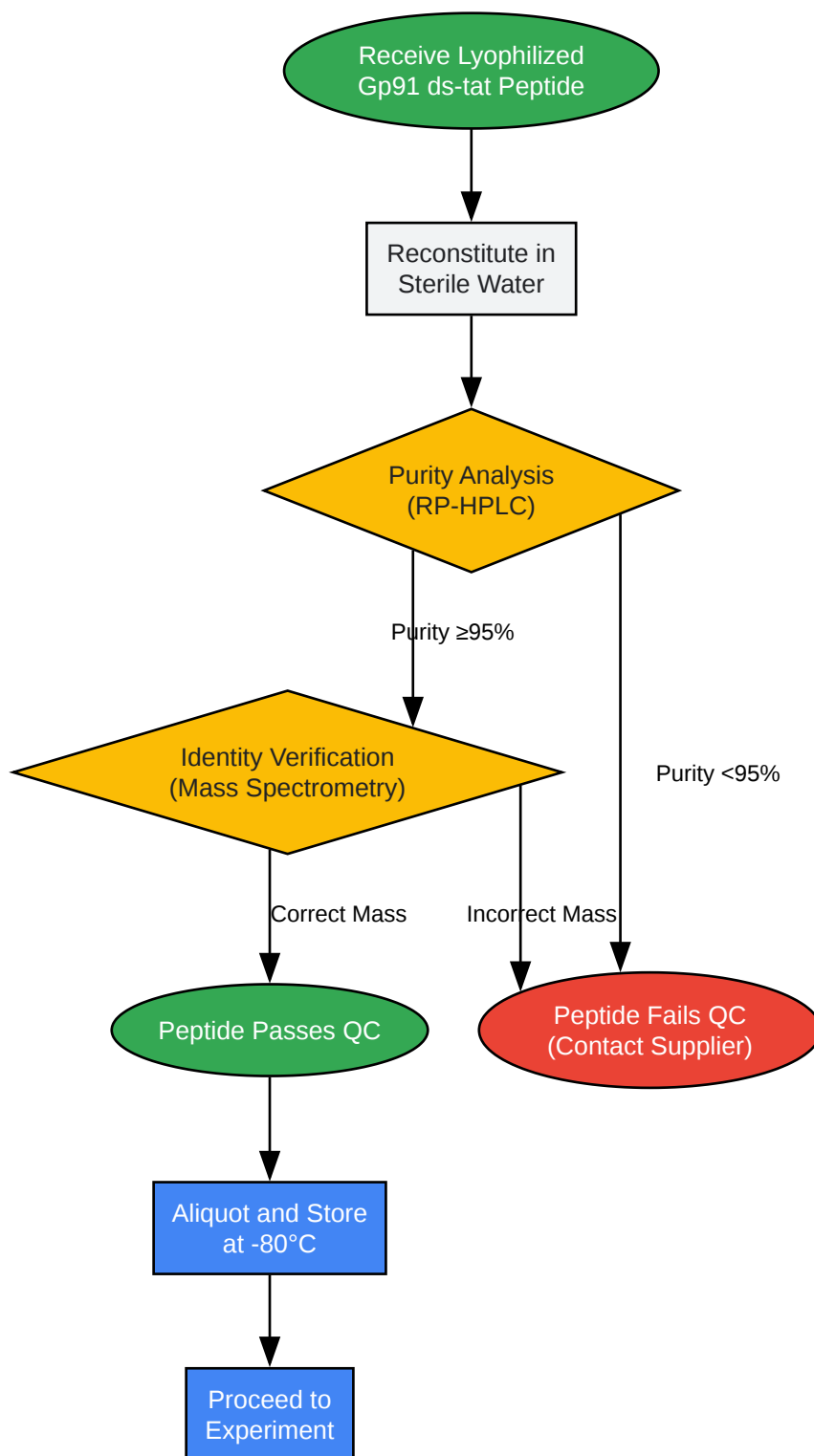

[Click to download full resolution via product page](#)

Caption: Quality control workflow for **Gp91 ds-tat** peptide.



[Click to download full resolution via product page](#)

Caption: Troubleshooting decision tree for **Gp91 ds-tat** experiments.

Need Custom Synthesis?

BenchChem offers custom synthesis for rare earth carbides and specific isotopic labeling.

Email: info@benchchem.com or [Request Quote Online](#).

References

- [1. gp91 ds-TAT | CRB1001119 | Biosynth \[biosynth.com\]](#)
- [2. researchgate.net \[researchgate.net\]](#)
- [3. researchgate.net \[researchgate.net\]](#)
- [4. medchemexpress.com \[medchemexpress.com\]](#)
- [5. NADPH Oxidase-Derived Reactive Oxygen Species Mediate the Cerebrovascular Dysfunction Induced by the Amyloid \$\beta\$ Peptide - PMC \[pmc.ncbi.nlm.nih.gov\]](#)
- [6. gp91 ds-tat Peptide 2 - 1 mg, 1 mg | Labscoop \[labscoop.com\]](#)
- [7. gp91 ds-tat Peptide 2 - 1 mg \[anaspec.com\]](#)
- [8. selleckchem.com \[selleckchem.com\]](#)
- [9. glpbio.com \[glpbio.com\]](#)
- [10. innopep.com \[innopep.com\]](#)
- [11. gp91 ds-tat, NADPH oxidase inhibitor - 1 mg \[anaspec.com\]](#)
- [12. pnas.org \[pnas.org\]](#)
- [13. ahajournals.org \[ahajournals.org\]](#)
- [14. resolvemass.ca \[resolvemass.ca\]](#)
- [15. Peptide Quality Control: Methods, Standards and Best Practices \[biolongevitylabs.com\]](#)
- [16. Revealing the cellular degradome by mass spectrometry analysis of proteasome-cleaved peptides - PubMed \[pubmed.ncbi.nlm.nih.gov\]](#)
- [17. Chapter 7 Mass spectrometry | Omics Data Analysis \[uclouvain-cbio.github.io\]](#)
- [18. Analysis of Proteasome-Generated Antigenic Peptides by Mass Spectrometry - PubMed \[pubmed.ncbi.nlm.nih.gov\]](#)
- To cite this document: BenchChem. [Gp91 ds-tat Peptide Technical Support Center]. BenchChem, [2026]. [Online PDF]. Available at:

[\[https://www.benchchem.com/product/b10830428/docs#gp91-ds-tat-peptide-technical-support-center\]](https://www.benchchem.com/product/b10830428/docs#gp91-ds-tat-peptide-technical-support-center)

Disclaimer & Data Validity:

The information provided in this document is for Research Use Only (RUO) and is strictly not intended for diagnostic or therapeutic procedures. While BenchChem strives to provide accurate protocols, we make no warranties, express or implied, regarding the fitness of this product for every specific experimental setup.

Technical Support: The protocols provided are for reference purposes. Unsure if this reagent suits your experiment?

Need Industrial/Bulk Grade? [Request Custom Synthesis Quote](#)

BenchChem

Our mission is to be the trusted global source of essential and advanced chemicals, empowering scientists and researchers to drive progress in science and industry.

Contact

Address: 3281 E Guasti Rd
Ontario, CA 91761, United States
Phone: (601) 213-4426
Email: info@benchchem.com

[Contact our Ph.D. Support Team for a compatibility check](#)