

Anizatrectinib Computational Docking and Modeling: A Technical Guide

Author: BenchChem Technical Support Team. **Date:** April 2026

Compound of Interest

Compound Name: Anizatrectinib
CAS No.: 1824664-89-2
Cat. No.: B10830844

[Get Quote](#)

For Researchers, Scientists, and Drug Development Professionals

Abstract

Anizatrectinib is a potent and selective inhibitor of Tropomyosin receptor kinase A (TrkA), a key driver in various oncogenic pathways. This technical guide provides a comprehensive overview of the computational docking and modeling approaches that can be applied to understand the molecular interactions between **anizatrectinib** and its target. While specific computational studies on **anizatrectinib** are not extensively published, this document outlines a robust, scientifically-grounded framework for such an investigation, drawing upon available data for **anizatrectinib**, its target TrkA, and analogous kinase inhibitors. This guide details hypothetical, yet plausible, experimental protocols, data interpretation, and visualizations to serve as a practical resource for researchers in the field of kinase inhibitor drug discovery.

Introduction

Anizatrectinib (also known as hTrkA-IN-1) is an orally active, synthetic organic compound designed to target TrkA kinase.[1][2] Dysregulation of the TrkA signaling pathway, often through gene fusions, is implicated in the progression of various cancers.[3] **Anizatrectinib** has

demonstrated potent inhibitory activity against TrkA, making it a promising candidate for targeted cancer therapy.[4][5] Computational docking and molecular modeling are indispensable tools in modern drug discovery, offering insights into the binding mechanisms, structure-activity relationships (SAR), and potential for off-target effects of small molecule inhibitors.[6] This guide outlines a comprehensive in silico approach to characterize the interaction of **anizatrectinib** with the TrkA kinase domain.

Anizatrectinib: Known Quantitative Data

While detailed computational studies on **anizatrectinib** are not publicly available, its potent in vitro activity against TrkA has been established. This provides a crucial validation point for any computational model.

Compound	Target	IC50 (nM)	Reference
Anizatrectinib	TrkA kinase	1.3	--INVALID-LINK--[4]

Molecular Docking of Anizatrectinib with TrkA Kinase

Molecular docking predicts the preferred orientation of a ligand when bound to a receptor, providing insights into binding affinity and the nature of the interactions.

Experimental Protocol: Molecular Docking

This protocol outlines a standard and robust procedure for docking **anizatrectinib** to the TrkA kinase domain.

1. Receptor Preparation:

- Obtain Crystal Structure: The crystal structure of the human TrkA kinase domain is retrieved from the Protein Data Bank (PDB). A suitable entry would be PDB ID: 5H3Q, which is a structure of TrkA in complex with an inhibitor.[7]
- Pre-processing: The protein structure is prepared using software such as Schrödinger's Protein Preparation Wizard or similar tools. This involves:
 - Removing water molecules and any co-crystallized ligands.
 - Adding hydrogen atoms.

- Assigning correct bond orders and protonation states.
- Optimizing the hydrogen-bonding network.
- A brief energy minimization step to relieve any steric clashes.

2. Ligand Preparation:

- Obtain Structure: The 2D structure of **anizatrectinib** is obtained from a chemical database like PubChem (CID 92135967).[8]
- 3D Conformation Generation: The 2D structure is converted into a 3D conformation. A tool like LigPrep can be used to generate multiple low-energy conformers and possible ionization states at physiological pH.

3. Grid Generation:

- A receptor grid is defined around the ATP-binding site of the TrkA kinase domain. The grid box is typically centered on the co-crystallized ligand from the original PDB structure to define the active site.

4. Molecular Docking:

- Docking Algorithm: A flexible ligand-rigid receptor docking algorithm, such as Glide (Schrödinger), AutoDock Vina, or GOLD, is employed.
- Execution: The prepared **anizatrectinib** conformers are docked into the defined receptor grid. The docking program will systematically search for the optimal binding pose by evaluating various translational, rotational, and conformational degrees of freedom of the ligand.
- Scoring: The resulting poses are ranked based on a scoring function (e.g., GlideScore, AutoDock binding energy) that estimates the binding affinity. The top-ranked poses are selected for further analysis.

Predicted Binding Mode and Key Interactions

Based on the structure of **anizatrectinib** and the known binding modes of other Trk inhibitors, the following interactions with the TrkA kinase domain are anticipated:

- Hinge Region Interaction: The urea moiety of **anizatrectinib** is likely to form crucial hydrogen bonds with the backbone amide and carbonyl groups of the hinge region residues (e.g.,

Met592, Glu590) of TrkA. This is a canonical interaction for ATP-competitive kinase inhibitors.

- **Hydrophobic Interactions:** The phenyl and fluorophenyl groups of **anizatrectinib** are expected to occupy hydrophobic pockets within the active site, forming van der Waals interactions with nonpolar residues.
- **Gatekeeper Residue Interaction:** The pyrazole and pyrimidine rings may interact with the gatekeeper residue (Phe589 in TrkA), which is a key determinant of inhibitor selectivity.
- **DFG Motif Interaction:** The molecule may also interact with the highly conserved DFG (Asp-Phe-Gly) motif in the activation loop.

In Silico ADMET Prediction

Predicting the Absorption, Distribution, Metabolism, Excretion, and Toxicity (ADMET) properties of a drug candidate is crucial for its development.

Experimental Protocol: In Silico ADMET

A variety of computational tools can be used to predict the ADMET profile of **anizatrectinib**.

1. Input Data:

- The SMILES string for **anizatrectinib** is obtained from a database like PubChem.[\[8\]](#)

2. Prediction Tools:

- Web-based platforms like SwissADME, pkCSM, or ADMETLab 2.0 can be utilized.[\[9\]](#)[\[10\]](#)[\[11\]](#) These tools employ a combination of QSAR models, machine learning algorithms, and structural alerts to predict various pharmacokinetic and toxicological endpoints.

3. Predicted Properties:

- **Absorption:** Intestinal absorption, Caco-2 permeability, and P-glycoprotein substrate potential.
- **Distribution:** Blood-brain barrier (BBB) penetration, plasma protein binding.
- **Metabolism:** Cytochrome P450 (CYP) inhibition and substrate specificity (e.g., CYP3A4, CYP2D6).

- Excretion: Prediction of renal clearance.
- Toxicity: Ames test for mutagenicity, hERG inhibition for cardiotoxicity, hepatotoxicity, and other potential toxicities.

Predicted ADMET Profile of Anizatrectinib

Based on its chemical properties, a hypothetical ADMET profile can be predicted.

Property	Predicted Value/Classification	Implication
Physicochemical Properties		
Molecular Weight	529.6 g/mol [8]	Compliant with Lipinski's Rule of Five
LogP	~3.5-4.3[8]	Good lipophilicity for cell permeability
H-bond Donors	2[8]	Compliant with Lipinski's Rule of Five
H-bond Acceptors	9[8]	Compliant with Lipinski's Rule of Five
Pharmacokinetics		
Intestinal Absorption	High	Good oral bioavailability
BBB Permeability	Likely to be a substrate of efflux pumps	May have limited CNS exposure
CYP Inhibition	Potential inhibitor of CYP isoforms	Risk of drug-drug interactions
Drug-Likeness		
Lipinski's Rule of Five	0 violations (predicted)	Favorable for oral bioavailability
Medicinal Chemistry		
Structural Alerts	No major alerts (predicted)	Low likelihood of intrinsic toxicity

Signaling Pathways and Experimental Workflows

Anizatreclinib exerts its therapeutic effect by inhibiting the TrkA signaling cascade.

TrkA Signaling Pathway

Upon binding of its ligand, Nerve Growth Factor (NGF), TrkA dimerizes and autophosphorylates, initiating downstream signaling cascades that promote cell survival and proliferation. Key pathways include the RAS/MEK/ERK (MAPK) pathway and the PI3K/AKT pathway.[3][12] **Anizatrectinib**, as an ATP-competitive inhibitor, blocks the initial autophosphorylation step, thereby inhibiting all downstream signaling.

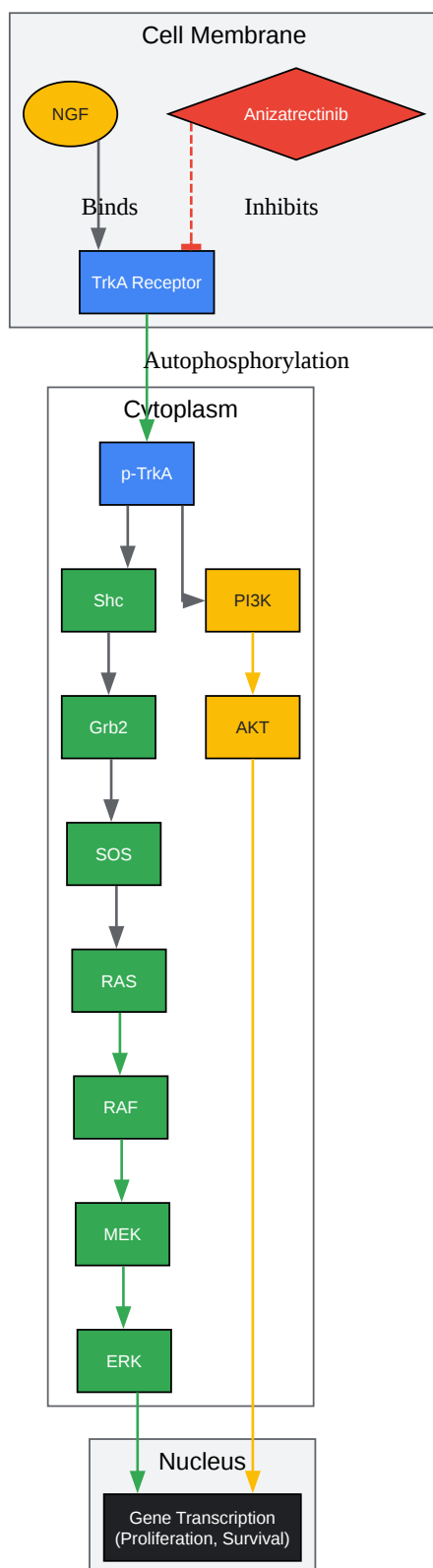

[Click to download full resolution via product page](#)

Anizatrectinib inhibits TrkA autophosphorylation, blocking downstream signaling.

Experimental Workflow for Anizatrectinib Evaluation

A typical workflow for the preclinical evaluation of a kinase inhibitor like **anizatrectinib** involves a combination of computational and experimental methods.

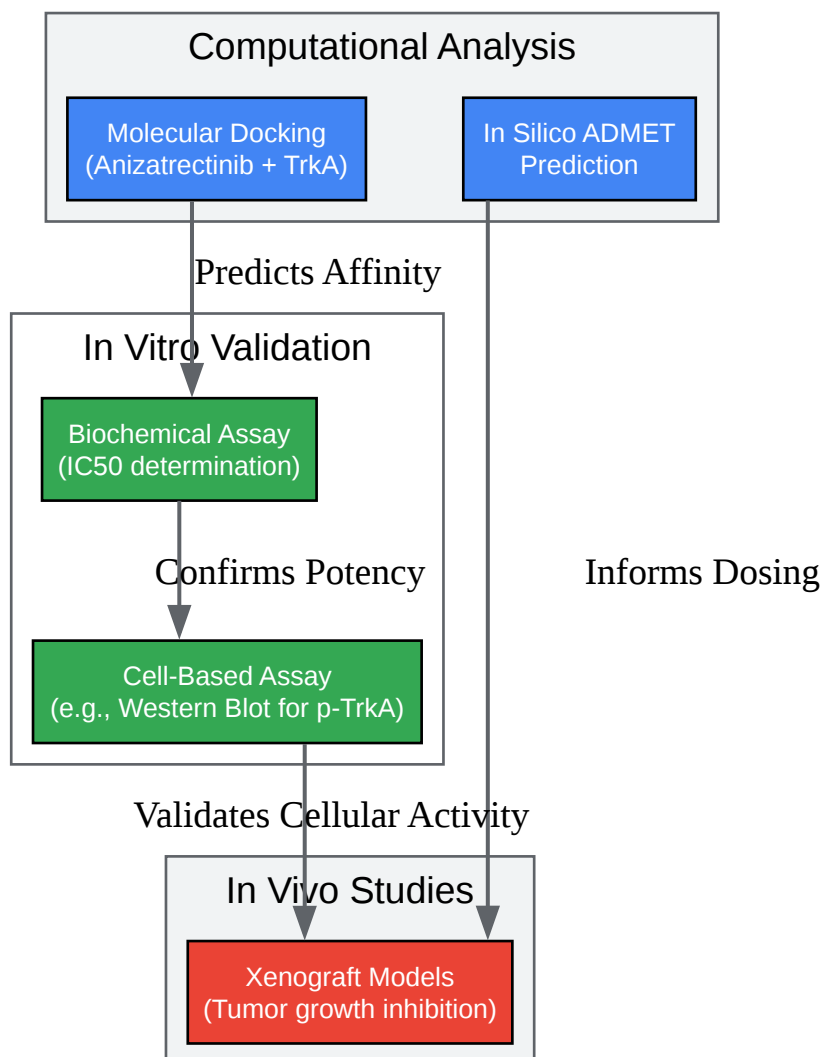

[Click to download full resolution via product page](#)

A multi-stage workflow for the evaluation of **anizatrectinib**.

Conclusion

This technical guide provides a comprehensive, albeit hypothetical, framework for the computational analysis of the TrkA inhibitor **anizatrectinib**. By leveraging existing structural data for the TrkA kinase and employing standard, validated computational methodologies,

researchers can gain significant insights into the binding mode, structure-activity relationships, and potential pharmacokinetic properties of this promising therapeutic agent. The protocols and workflows outlined herein serve as a valuable resource for guiding future in silico and experimental studies, ultimately accelerating the development of novel kinase inhibitors for the treatment of cancer.

Need Custom Synthesis?

BenchChem offers custom synthesis for rare earth carbides and specific isotopic labeling.

Email: info@benchchem.com or [Request Quote Online](#).

References

- [1. anizatrektinib | Ligand page | IUPHAR/BPS Guide to PHARMACOLOGY \[guidetopharmacology.org\]](#)
- [2. anizatrektinib | Ligand page | IUPHAR/BPS Guide to PHARMACOLOGY \[guidetopharmacology.org\]](#)
- [3. TRK Inhibitor Activity and Resistance in TRK Fusion-Positive Cancers in Adults - PMC \[pmc.ncbi.nlm.nih.gov\]](#)
- [4. medkoo.com \[medkoo.com\]](#)
- [5. Anizatrektinib|CAS 1824664-89-2|DC Chemicals \[dcchemicals.com\]](#)
- [6. researchgate.net \[researchgate.net\]](#)
- [7. rcsb.org \[rcsb.org\]](#)
- [8. Anizatrektinib | C29H32FN7O2 | CID 92135967 - PubChem \[pubchem.ncbi.nlm.nih.gov\]](#)
- [9. Open access in silico tools to predict the ADMET profiling of drug candidates - PubMed \[pubmed.ncbi.nlm.nih.gov\]](#)
- [10. researchgate.net \[researchgate.net\]](#)
- [11. taylorfrancis.com \[taylorfrancis.com\]](#)
- [12. What is the mechanism of Entrectinib? \[synapse.patsnap.com\]](#)
- To cite this document: BenchChem. [Anizatrektinib Computational Docking and Modeling: A Technical Guide]. BenchChem, [2026]. [Online PDF]. Available at: [\[https://www.benchchem.com/product/b10830844/docs#anizatrektinib-computational-docking-and-modeling-a-technical-guide\]](https://www.benchchem.com/product/b10830844/docs#anizatrektinib-computational-docking-and-modeling-a-technical-guide)

Disclaimer & Data Validity:

The information provided in this document is for Research Use Only (RUO) and is strictly not intended for diagnostic or therapeutic procedures. While BenchChem strives to provide accurate protocols, we make no warranties, express or implied, regarding the fitness of this product for every specific experimental setup.

Technical Support: The protocols provided are for reference purposes. Unsure if this reagent suits your experiment?

Need Industrial/Bulk Grade? [Request Custom Synthesis Quote](#)

BenchChem

Our mission is to be the trusted global source of essential and advanced chemicals, empowering scientists and researchers to drive progress in science and industry.

Contact

Address: 3281 E Guasti Rd

Ontario, CA 91761, United States

Phone: (601) 213-4426

Email: info@benchchem.com

[Contact our Ph.D. Support Team for a compatibility check](#)