

Anizatrectinib: A Comprehensive Technical Guide on its Role in Signaling Pathways

Author: BenchChem Technical Support Team. **Date:** April 2026

Compound of Interest

Compound Name: Anizatrectinib

CAS No.: 1824664-89-2

Cat. No.: B10830844

[Get Quote](#)

For Researchers, Scientists, and Drug Development Professionals

Anizatrectinib, also known as entrectinib, is a potent and selective tyrosine kinase inhibitor (TKI) that has emerged as a significant therapeutic agent in precision oncology.^{[1][2][3]} This guide provides an in-depth analysis of its mechanism of action, its role in key signaling pathways, and the molecular basis of both its efficacy and the development of resistance.

Core Mechanism of Action

Anizatrectinib is an orally bioavailable, ATP-competitive inhibitor targeting the tropomyosin receptor kinases (TRK) A, B, and C (encoded by NTRK1, NTRK2, and NTRK3 genes, respectively), the C-ros oncogene 1 (ROS1), and the anaplastic lymphoma kinase (ALK).^{[1][2][3][4]} In specific cancers, chromosomal rearrangements lead to the creation of fusion genes involving NTRK, ROS1, or ALK.^[1] These fusion events result in the expression of chimeric proteins with constitutively active kinase domains, which function as oncogenic drivers.^{[1][4]} These aberrant kinases perpetually activate downstream signaling pathways, promoting uncontrolled cell proliferation and survival, a phenomenon known as "oncogene addiction".^[1]

Anizatrectinib functions by binding to the ATP-binding site of these fusion kinases, effectively blocking their catalytic activity and inhibiting the downstream signaling cascades crucial for tumor growth and survival.[2][4] A key feature of **anizatrectinib** is its design to cross the blood-brain barrier, allowing it to achieve therapeutic concentrations in the central nervous system (CNS) and treat primary or metastatic brain lesions.[4][5][6]

Modulation of Core Signaling Pathways

The oncogenic activity of NTRK, ROS1, and ALK fusion proteins is primarily mediated through the activation of two critical downstream signaling pathways: the RAS/RAF/MEK/ERK (MAPK) pathway and the Phosphoinositide 3-kinase (PI3K)/AKT pathway.[4] ALK fusions can also activate the JAK/STAT pathway.[2]

- **MAPK Pathway:** This pathway is a central regulator of cell proliferation, differentiation, and survival. Constitutive kinase activity leads to sustained ERK activation, promoting cell cycle progression and tumor growth.
- **PI3K/AKT Pathway:** This pathway is critical for cell survival, growth, and metabolism. Its activation by the fusion kinases inhibits apoptosis and supports the metabolic demands of cancer cells.

Anizatrectinib's inhibition of the upstream fusion kinase leads to the suppression of these pathways, resulting in cell growth arrest and apoptosis.[2][4]

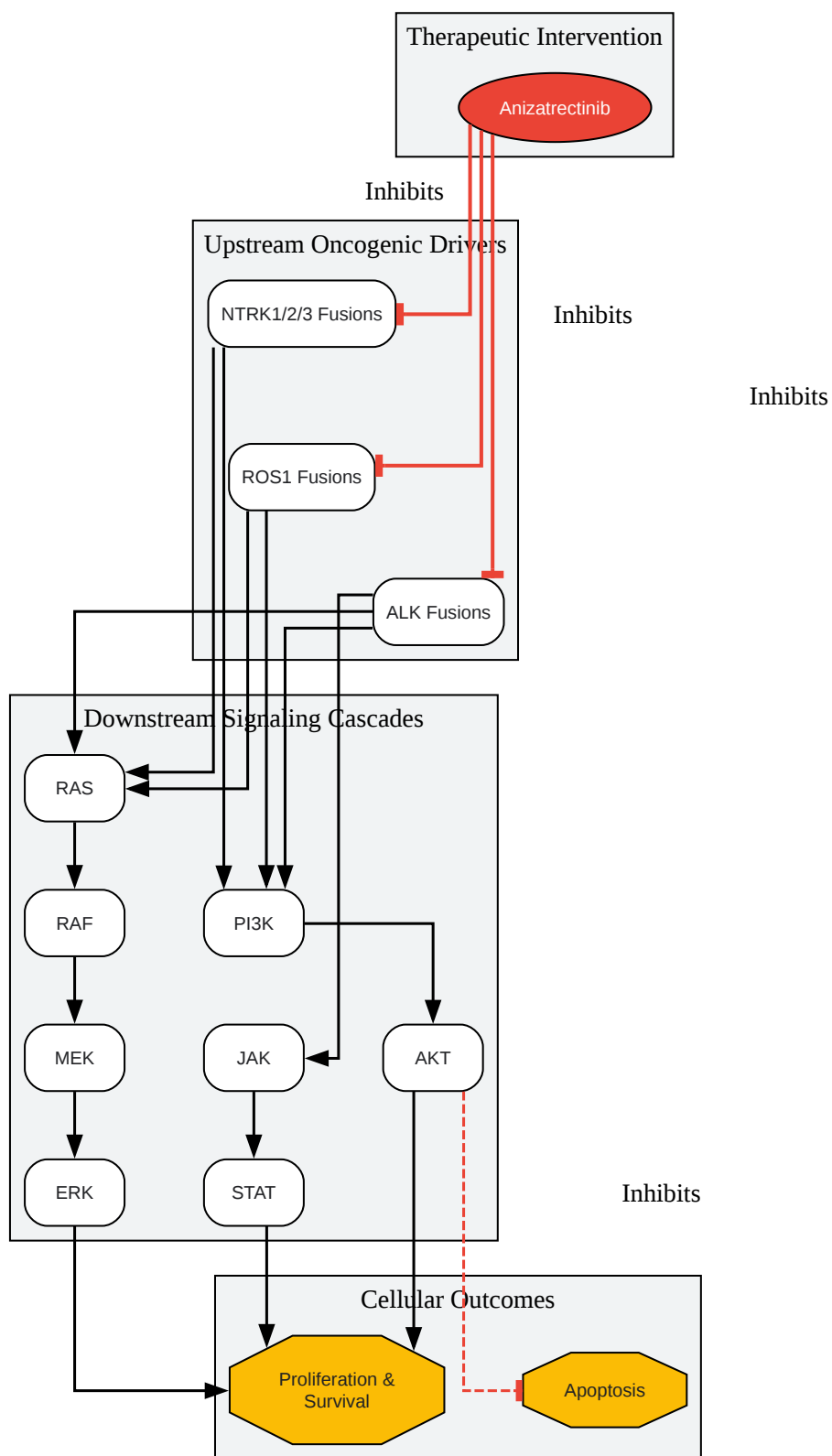

[Click to download full resolution via product page](#)

Caption: **Anizatrektinib** inhibits oncogenic NTRK, ROS1, and ALK fusions, blocking downstream MAPK and PI3K/AKT pathways.

Quantitative Data Summary

The efficacy of **anizatrektinib** has been demonstrated in numerous preclinical and clinical studies. The following tables summarize key quantitative data.

Table 1: In Vitro Kinase Inhibitory Activity of **Anizatrektinib**

Kinase Target	IC50 (nmol/L)	Reference
TRKA	1	[7]
TRKB	3	[7]
ROS1	7	[7]
ALK	12	[7]
JAK2	40	[7]

Note: Lower IC50 values indicate greater potency.

Table 2: Clinical Efficacy in NTRK Fusion-Positive Solid Tumors (Integrated Analysis)

Endpoint	Result	95% Confidence Interval (CI)	Reference(s)
Systemic Efficacy (n=121)			
Objective Response Rate (ORR)	61.2%	-	[8]
Complete Response (CR)	15.7% (n=19)	-	[8]
Partial Response (PR)	45.5% (n=55)	-	[8]
Median Duration of Response (DoR)	20.0 months	13.0 – 38.2	[8]
Median Progression-Free Survival (PFS)	13.8 months	10.1 – 19.9	[8][9]
Intracranial Efficacy (n=11 with measurable CNS disease)			
Intracranial ORR	63.6%	30.8 – 89.1	[8]
Median Intracranial DoR	22.1 months	7.4 – Not Estimable	[8]

Data from an integrated analysis of ALKA-372-001, STARTRK-1, and STARTRK-2 trials with a median follow-up of 25.8 months.[8]

Table 3: Clinical Efficacy in ROS1 Fusion-Positive NSCLC (Integrated Analysis)

Endpoint	Result	95% Confidence Interval (CI)	Reference(s)
Systemic Efficacy (n=168, TKI-naïve)			
Objective Response Rate (ORR)	68%	60.2 – 74.8	[10]
Median Duration of Response (DoR)	20.5 months	-	[10]
Median Progression-Free Survival (PFS)	15.7 months	12.0 – 21.1	[10]
Median Overall Survival (OS)	47.8 months	44.1 – Not Estimable	[10]
Intracranial Efficacy (n=25 with measurable CNS disease)			
Intracranial ORR	80%	59.3 – 93.2	[10]
Median Intracranial DoR	12.9 months	-	[10]
Median Intracranial PFS	8.8 months	-	[10]

Data from an updated integrated analysis of ALKA-372-001, STARTRK-1, and STARTRK-2 trials with a median follow-up of 29.1 months.[10]

Experimental Protocols and Methodologies

The characterization of **anizatrectinib**'s activity involves a range of standard preclinical and clinical methodologies.

Biochemical Kinase Assays:

- Objective: To determine the potency and selectivity of **anizatrectinib** against a panel of purified kinases.
- Methodology: Radiometric assays are commonly used.[7] The kinase, substrate (e.g., a generic peptide), and radiolabeled ATP (e.g., ³³P-ATP) are incubated with varying concentrations of the inhibitor. The amount of incorporated radiolabel into the substrate is measured, allowing for the calculation of IC50 values. To determine the mechanism of inhibition (e.g., ATP-competitive), kinetic studies are performed by measuring enzyme activity at different concentrations of both ATP and the inhibitor, followed by analysis using Lineweaver-Burk (reciprocal) plots.[7]

Cell-Based Assays:

- Objective: To evaluate the effect of **anizatrectinib** on cancer cells harboring the target fusions.
- Methodology:
 - Antiproliferative Assays: Tumor cell lines dependent on NTRK, ROS1, or ALK fusions (e.g., KM12 colorectal cells with a TPM3-NTRK1 fusion) are treated with a dose range of **anizatrectinib** for a set period (e.g., 72 hours).[7] Cell viability is then measured using reagents like resazurin or CellTiter-Glo®.
 - Western Blot Analysis: Cells are treated with **anizatrectinib** for a short duration (e.g., 2-4 hours).[7][11] Cell lysates are then prepared, and proteins are separated by SDS-PAGE. Specific antibodies are used to detect the phosphorylation status of target kinases (e.g., p-TRKA, p-ROS1) and downstream effectors (p-AKT, p-ERK) to confirm pathway inhibition. [7][11]

In Vivo Xenograft Models:

- Objective: To assess the anti-tumor efficacy of **anizatrectinib** in a living organism.
- Methodology: Human tumor cell lines (e.g., KM12) are implanted subcutaneously into immunocompromised mice.[12] Once tumors are established, mice are treated with oral doses of **anizatrectinib** or a vehicle control. Tumor volume is measured regularly to assess

tumor growth inhibition or regression.[12] For CNS efficacy, intracranial tumor models are used.[6]

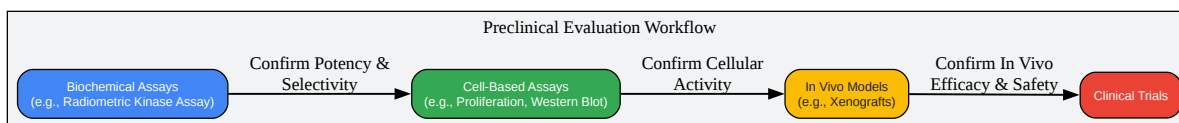

[Click to download full resolution via product page](#)

Caption: A simplified workflow for the preclinical evaluation of a tyrosine kinase inhibitor like **anizatrectinib**.

Mechanisms of Acquired Resistance

Despite the durable responses, acquired resistance to **anizatrectinib** can emerge over time, limiting long-term efficacy.[13] Mechanisms are broadly categorized as on-target or off-target.

On-Target Resistance: This involves the acquisition of secondary mutations within the kinase domain of the target fusion protein, which interfere with drug binding.

- Solvent Front Mutations: (e.g., NTRK1 G595R) prevent inhibitor binding through steric hindrance.[14]
- Gatekeeper Mutations: (e.g., NTRK3 G623R) can also confer resistance.[13]

Off-Target Resistance: This occurs when cancer cells activate alternative "bypass" signaling pathways to reactivate downstream effectors like ERK and AKT, rendering the inhibition of the primary oncogene ineffective.

- RAS Pathway Activation: Acquired mutations (e.g., KRAS G12C) or amplification of KRAS can lead to sustained ERK activation despite ROS1 inhibition.[13]
- MET Pathway Activation: Overexpression of Hepatocyte Growth Factor (HGF) in the tumor microenvironment can activate the MET receptor tyrosine kinase, which in turn reactivates

the PI3K/AKT and MAPK pathways, conferring resistance.[11][15] This resistance can be overcome by co-targeting MET.[11]

- IGF1R Activation: The Insulin-like Growth Factor 1 Receptor (IGF1R) pathway has also been identified as a potential bypass track.[14][16]

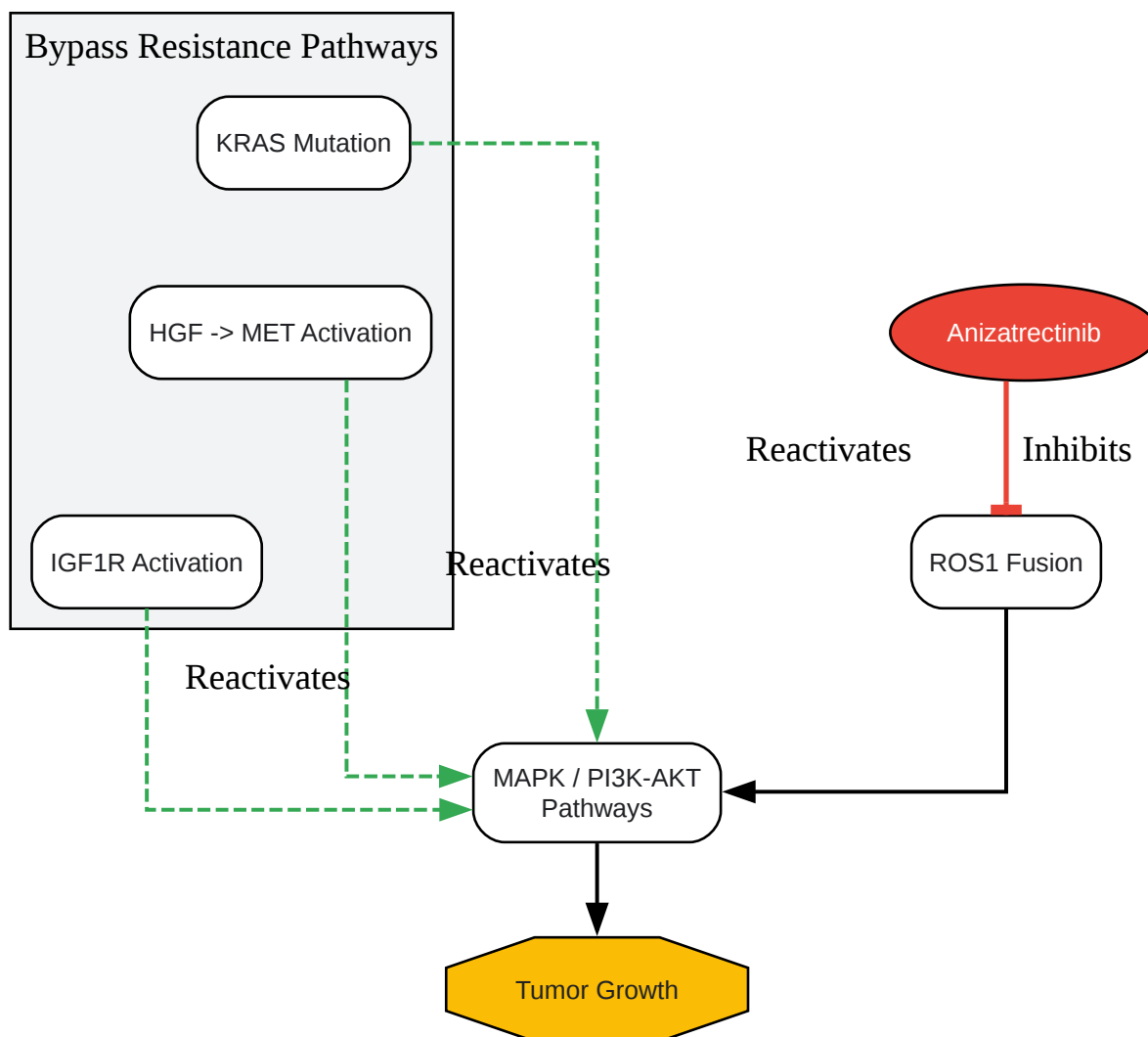

[Click to download full resolution via product page](#)

Caption: Off-target resistance to **anizatrectinib** can occur via activation of bypass pathways like KRAS, MET, or IGF1R.

Conclusion

Anizatrektinib is a highly effective TKI that induces durable systemic and intracranial responses in patients with tumors harboring NTRK, ROS1, or ALK gene fusions.[8][10] Its mechanism is centered on the potent inhibition of these oncogenic drivers and the subsequent suppression of critical downstream signaling pathways. Understanding the molecular landscape of both sensitivity and resistance is paramount for optimizing its clinical use, developing rational combination strategies to overcome resistance, and improving patient outcomes in the era of personalized medicine.

Need Custom Synthesis?

BenchChem offers custom synthesis for rare earth carbides and specific isotopic labeling.

Email: info@benchchem.com or [Request Quote Online](#).

References

- [1. Entrectinib - Wikipedia \[en.wikipedia.org\]](#)
- [2. go.drugbank.com \[go.drugbank.com\]](#)
- [3. Entrectinib: A New Selective Tyrosine Kinase Inhibitor Approved for the Treatment of Pediatric and Adult Patients with NTRK Fusionpositive, Recurrent or Advanced Solid Tumors - PubMed \[pubmed.ncbi.nlm.nih.gov\]](#)
- [4. What is the mechanism of Entrectinib? \[synapse.patsnap.com\]](#)
- [5. onclive.com \[onclive.com\]](#)
- [6. P14.19 Preclinical and clinical efficacy of entrectinib in primary and metastatic brain tumors harboring NTRK, ROS1, or ALK gene fusions - PMC \[pmc.ncbi.nlm.nih.gov\]](#)
- [7. researchgate.net \[researchgate.net\]](#)
- [8. Updated Integrated Analysis of the Efficacy and Safety of Entrectinib in Patients With NTRK Fusion-Positive Solid Tumors - PMC \[pmc.ncbi.nlm.nih.gov\]](#)
- [9. Clinical Review - Entrectinib \(Rozlytrek\) - NCBI Bookshelf \[ncbi.nlm.nih.gov\]](#)
- [10. Long-Term Efficacy and Safety of Entrectinib in ROS1 Fusion-Positive NSCLC - PMC \[pmc.ncbi.nlm.nih.gov\]](#)
- [11. MET kinase inhibitor reverses resistance to entrectinib induced by hepatocyte growth factor in tumors with NTRK1 or ROS1 rearrangements - PMC \[pmc.ncbi.nlm.nih.gov\]](#)

- [12. Entrectinib, a Pan-TRK, ROS1 and ALK Inhibitor with Activity in Multiple Molecularly Defined Cancer Indications \[en-cancer.fr\]](#)
- [13. Entrectinib resistance mechanisms in ROS1-rearranged non-small cell lung cancer - PMC \[pmc.ncbi.nlm.nih.gov\]](#)
- [14. Mechanisms of Resistance to NTRK Inhibitors and Therapeutic Strategies in NTRK1-Rearranged Cancers - PubMed \[pubmed.ncbi.nlm.nih.gov\]](#)
- [15. MET kinase inhibitor reverses resistance to entrectinib induced by hepatocyte growth factor in tumors with NTRK1 or ROS1 rearrangements - PubMed \[pubmed.ncbi.nlm.nih.gov\]](#)
- [16. Current therapeutic landscape and resistance mechanisms to larotrectinib - PMC \[pmc.ncbi.nlm.nih.gov\]](#)
- To cite this document: BenchChem. [Anizatreectinib: A Comprehensive Technical Guide on its Role in Signaling Pathways]. BenchChem, [2026]. [Online PDF]. Available at: [\[https://www.benchchem.com/product/b10830844/docs#anizatreectinib-a-comprehensive-technical-guide-on-its-role-in-signaling-pathways\]](https://www.benchchem.com/product/b10830844/docs#anizatreectinib-a-comprehensive-technical-guide-on-its-role-in-signaling-pathways)

Disclaimer & Data Validity:

The information provided in this document is for Research Use Only (RUO) and is strictly not intended for diagnostic or therapeutic procedures. While BenchChem strives to provide accurate protocols, we make no warranties, express or implied, regarding the fitness of this product for every specific experimental setup.

Technical Support: The protocols provided are for reference purposes. Unsure if this reagent suits your experiment?

Need Industrial/Bulk Grade? [Request Custom Synthesis Quote](#)

BenchChem

Our mission is to be the trusted global source of essential and advanced chemicals, empowering scientists and researchers to drive progress in science and industry.

Contact

Address: 3281 E Guasti Rd

Ontario, CA 91761, United States

Phone: (601) 213-4426

Email: info@benchchem.com

Contact our Ph.D. Support Team for a compatibility check