

Strategies to increase the potency of Cjoc42 derivatives

Author: BenchChem Technical Support Team. **Date:** April 2026

Compound of Interest

Compound Name: Cjoc42
Cat. No.: B10829403

[Get Quote](#)

Technical Support Center: EGFR Inhibitor Derivatives

Welcome to the technical support center for the optimization and application of Epidermal Growth Factor Receptor (EGFR) inhibitor derivatives. This resource provides troubleshooting guides, frequently asked questions (FAQs), and detailed protocols to assist researchers, scientists, and drug development professionals in their experiments.

Frequently Asked Questions (FAQs)

Q1: We are observing suboptimal potency with our initial EGFR inhibitor lead compound. What are the primary strategies to increase its potency?

A1: Increasing the potency of EGFR inhibitors often involves a multi-pronged approach focused on optimizing the molecule's interaction with the target and its overall pharmacological properties. Key strategies include:

- **Structure-Activity Relationship (SAR) Studies:** Systematically modify different parts of the molecule to enhance binding affinity. For many EGFR inhibitors with a quinazoline core,

modifications at specific positions can significantly impact potency. For instance, introducing urea linkers has been shown to be more favorable for inhibitory activity compared to thiourea-containing derivatives.[1]

- Targeting Resistant Mutants: The effectiveness of first-generation EGFR inhibitors can be limited by mutations such as T790M.[2][3] Second and third-generation inhibitors are designed to overcome this resistance. For example, third-generation inhibitors like osimertinib form a covalent bond with the C797 residue in the EGFR ATP-binding site, providing potent inhibition against resistant mutants.[4]
- Allosteric Inhibition: Instead of targeting the highly conserved ATP-binding site, allosteric inhibitors bind to a different site on the kinase, which can offer a novel mechanism to overcome resistance.[5][6]
- Combination Therapy: Combining EGFR inhibitors with other therapeutic agents can lead to synergistic effects. This can include combining with inhibitors of downstream signaling pathways (e.g., MEK inhibitors), other receptor tyrosine kinases, or even with monoclonal antibodies that target the extracellular domain of EGFR.[7][8][9]

Q2: What are the key signaling pathways downstream of EGFR that we should monitor to assess the efficacy of our inhibitors?

A2: Upon activation, EGFR initiates several downstream signaling cascades that are crucial for cell proliferation, survival, and differentiation.[10][11] The primary pathways to monitor are:

- RAS-RAF-MEK-ERK (MAPK) Pathway: This pathway is a major driver of cell proliferation. [12][13] Assessing the phosphorylation status of ERK is a common method to determine the inhibitory effect on this pathway.
- PI3K-AKT-mTOR Pathway: This pathway is essential for promoting cell survival and growth. [12][13] Monitoring the phosphorylation of AKT and downstream targets like mTOR can provide insights into the inhibitor's effect on cell survival.
- JAK/STAT Pathway: EGFR activation can also lead to the phosphorylation of STAT proteins, which are involved in the transcription of genes associated with cell survival.[13][14]

Q3: How do different generations of EGFR inhibitors vary in their mechanism of action?

A3: EGFR inhibitors are broadly classified into different generations based on their mechanism of action and their effectiveness against resistance mutations:

- First-Generation (e.g., Gefitinib, Erlotinib): These are reversible inhibitors that compete with ATP for binding to the tyrosine kinase domain of EGFR.[15] They are effective against activating mutations like L858R but are less effective against resistance mutations like T790M.[1][2]
- Second-Generation (e.g., Afatinib, Dacomitinib): These are irreversible inhibitors that form a covalent bond with a cysteine residue in the ATP-binding pocket of EGFR.[4][15] They have broader activity against other ErbB family members but can have increased toxicity due to their effect on wild-type EGFR.[2]
- Third-Generation (e.g., Osimertinib): These are also irreversible inhibitors but are designed to be more selective for EGFR-activating mutations and the T790M resistance mutation, while having less of an effect on wild-type EGFR.[4]

Troubleshooting Guides

In Vitro Kinase Assays

Problem	Potential Causes	Recommended Solutions
High variability in IC50 values between experiments	Inconsistent enzyme activity, inaccurate pipetting, or degradation of ATP or substrate.	Ensure consistent enzyme lots and activity. Calibrate pipettes regularly. Prepare fresh ATP and substrate solutions for each experiment.
No or very weak inhibition observed	Incorrect assay conditions (e.g., ATP concentration too high), inactive compound, or enzyme concentration too low.	Optimize the ATP concentration to be close to the K_m value. ^[16] Confirm the identity and purity of the inhibitor. Determine the optimal enzyme concentration needed for a robust signal. ^[16]
Compound interferes with the assay signal	The compound may have intrinsic fluorescence or may interfere with the detection reagents.	Run a control experiment with the compound in the absence of the enzyme to check for interference. ^{[17][18]} If interference is observed, consider using an alternative assay format (e.g., radiometric vs. fluorescence-based).

Cell-Based Assays

Problem	Potential Causes	Recommended Solutions
Inconsistent results in cell viability assays	Cell line authenticity and high passage number, variations in cell seeding density, or inconsistent drug incubation times. [17]	Use authenticated, low-passage cell lines. Ensure a homogenous cell suspension before and during plating. Strictly adhere to consistent incubation times. [18]
High variability between replicate wells	Uneven cell seeding, pipetting errors, or "edge effects" in the microplate. [17]	Ensure the cell suspension is well-mixed. Use calibrated pipettes. To mitigate evaporation, fill the outer wells of the plate with sterile media or PBS and do not use them for experimental samples. [17]
No significant effect of the inhibitor on cell proliferation	The chosen cell line may not be dependent on the EGFR pathway, may have resistance mutations (e.g., KRAS mutations), or the compound concentration may be too low. [18]	Confirm that the cell line is dependent on EGFR signaling for proliferation. [12] Check the mutational status of the cell line. Perform a dose-response experiment with a wider range of concentrations. [18]

Data Presentation

Table 1: In Vitro Kinase Inhibition of a Representative EGFR Inhibitor

Target Kinase	IC ₅₀ (nM)
EGFR (Wild-Type)	5.2
EGFR (L858R)	1.8
EGFR (T790M)	15.6
HER2	89.4
HER4	>1000

Data is representative and sourced for illustrative purposes.[19]

Table 2: Cellular Proliferation Inhibition of a Representative EGFR Inhibitor

Cell Line	EGFR Status	GI ₅₀ (nM)
A431	Wild-Type Overexpression	25.1
NCI-H1975	L858R/T790M	42.5
PC-9	del E746-A750	15.8
SW620	KRAS Mutant (EGFR WT)	>10,000

Data is representative and sourced for illustrative purposes.[19]

Experimental Protocols

Protocol 1: In Vitro EGFR Kinase Assay (Luminescence-Based)

This protocol is based on an assay that measures the amount of ADP produced during the kinase reaction.[20][21]

Materials:

- Recombinant human EGFR enzyme
- Peptide substrate (e.g., Poly(Glu, Tyr) 4:1)
- ATP
- Kinase assay buffer (e.g., 40mM Tris, pH 7.5; 20mM MgCl₂; 0.1mg/ml BSA; 50μM DTT)[21]
- EGFR inhibitor (dissolved in DMSO)
- ADP-Glo™ Kinase Assay Kit
- 96-well or 384-well plates

Procedure:

- **Reagent Preparation:** Prepare serial dilutions of the EGFR inhibitor in the kinase assay buffer. The final DMSO concentration should not exceed 1%. Prepare a master mix containing the peptide substrate and ATP in the kinase assay buffer.[20]
- **Kinase Reaction:** In a multi-well plate, add the diluted inhibitor or vehicle control (DMSO). Add the kinase reaction master mix. Initiate the reaction by adding the diluted EGFR enzyme.[20]
- **Incubation:** Incubate the plate at 30°C for 60 minutes.[20]
- **ADP Detection:** Stop the kinase reaction and deplete the remaining ATP by adding the ADP-Glo™ Reagent. Incubate at room temperature for 40 minutes.[21]
- **Signal Generation:** Add the Kinase Detection Reagent to convert the generated ADP to ATP and produce a luminescent signal. Incubate at room temperature for 30 minutes.[21]
- **Data Acquisition:** Measure the luminescence using a plate-reading luminometer.
- **Data Analysis:** Subtract the background luminescence (no enzyme control) from all readings and calculate the IC50 values.

Protocol 2: Cell Proliferation Assay (MTT Assay)

This protocol measures the metabolic activity of viable cells to determine the effect of the inhibitor on cell proliferation.[19][22]

Materials:

- EGFR-dependent cancer cell line (e.g., A431, NCI-H1975)
- Complete cell culture medium
- EGFR inhibitor (dissolved in DMSO)
- MTT solution (5 mg/mL in PBS)

- Solubilization solution (e.g., DMSO)
- 96-well plates

Procedure:

- Cell Seeding: Seed the cells in a 96-well plate at a predetermined optimal density and allow them to adhere overnight.[19]
- Drug Treatment: Prepare serial dilutions of the EGFR inhibitor in the complete cell culture medium. Replace the old medium with the medium containing the inhibitor or vehicle control (DMSO).[22]
- Incubation: Incubate the plate for 72 hours at 37°C and 5% CO₂.[22]
- MTT Addition: Add MTT solution to each well and incubate for 2-4 hours at 37°C to allow for the formation of formazan crystals.[17]
- Solubilization: Carefully remove the medium and add the solubilization solution to dissolve the formazan crystals.[19]
- Data Acquisition: Measure the absorbance at 570 nm using a microplate reader.
- Data Analysis: Calculate the percentage of cell viability for each concentration relative to the vehicle control and determine the GI50 value.[22]

Visualizations

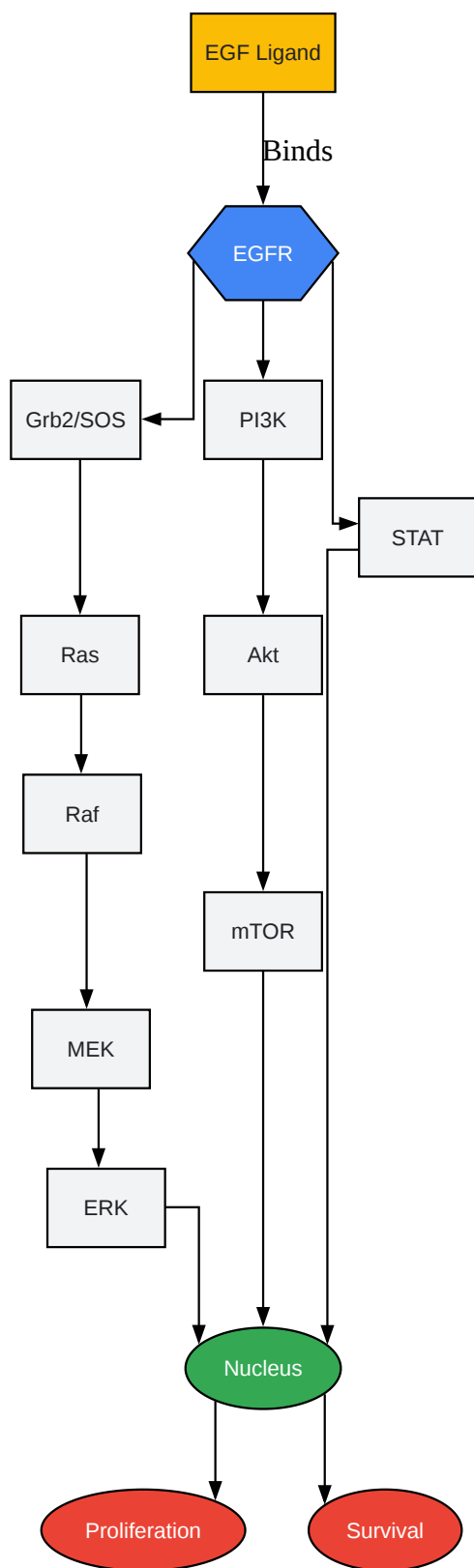

[Click to download full resolution via product page](#)

Caption: Simplified EGFR signaling pathways leading to cell proliferation and survival.

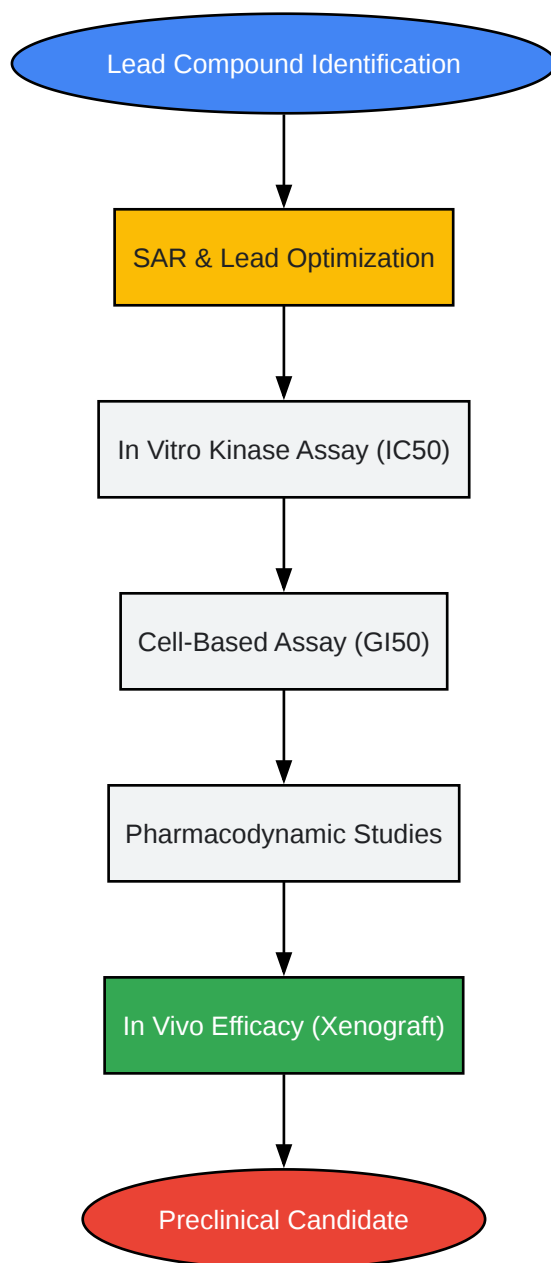

[Click to download full resolution via product page](#)

Need Custom Synthesis?

BenchChem offers custom synthesis for rare earth carbides and specific isotopic labeling.

Email: info@benchchem.com or [Request Quote Online](#).

References

- [1. Structure–Activity Relationship Studies Based on Quinazoline Derivatives as EGFR Kinase Inhibitors \(2017–Present\) - PMC \[pmc.ncbi.nlm.nih.gov\]](#)
- [2. pubs.acs.org \[pubs.acs.org\]](#)
- [3. Challenges of EGFR-TKIs in NSCLC and the potential role of herbs and active compounds: From mechanism to clinical practice - PMC \[pmc.ncbi.nlm.nih.gov\]](#)
- [4. Targeted Inhibitors of EGFR: Structure, Biology, Biomarkers, and Clinical Applications \[mdpi.com\]](#)
- [5. Emerging strategies to overcome resistance to third-generation EGFR inhibitors - PMC \[pmc.ncbi.nlm.nih.gov\]](#)
- [6. Structure–Activity Relationships of Inactive-Conformation Binding EGFR Inhibitors: Linking the ATP and Allosteric Pockets - PMC \[pmc.ncbi.nlm.nih.gov\]](#)
- [7. aacrjournals.org \[aacrjournals.org\]](#)
- [8. “Sandwich” Strategy to Intensify EGFR Blockade by Concurrent Tyrosine Kinase Inhibitor and Monoclonal Antibody Treatment in Highly Selected Patients - PMC \[pmc.ncbi.nlm.nih.gov\]](#)
- [9. What's the latest update on the ongoing clinical trials related to EGFR? \[synapse.patsnap.com\]](#)
- [10. A comprehensive pathway map of epidermal growth factor receptor signaling - PMC \[pmc.ncbi.nlm.nih.gov\]](#)
- [11. creative-diagnostics.com \[creative-diagnostics.com\]](#)
- [12. benchchem.com \[benchchem.com\]](#)
- [13. ClinPGx \[clinpgx.org\]](#)
- [14. lifesciences.danaher.com \[lifesciences.danaher.com\]](#)
- [15. Strategies for Overcoming Resistance to EGFR Family Tyrosine Kinase Inhibitors - PMC \[pmc.ncbi.nlm.nih.gov\]](#)
- [16. documents.thermofisher.com \[documents.thermofisher.com\]](#)
- [17. benchchem.com \[benchchem.com\]](#)
- [18. benchchem.com \[benchchem.com\]](#)
- [19. benchchem.com \[benchchem.com\]](#)
- [20. benchchem.com \[benchchem.com\]](#)
- [21. promega.com \[promega.com\]](#)
- [22. benchchem.com \[benchchem.com\]](#)

- To cite this document: BenchChem. [Strategies to increase the potency of Cjoc42 derivatives]. BenchChem, [2026]. [Online PDF]. Available at: [<https://www.benchchem.com/product/b10829403/docs#strategies-to-increase-the-potency-of-cjoc42-derivatives>]

Disclaimer & Data Validity:

The information provided in this document is for Research Use Only (RUO) and is strictly not intended for diagnostic or therapeutic procedures. While BenchChem strives to provide accurate protocols, we make no warranties, express or implied, regarding the fitness of this product for every specific experimental setup.

Technical Support: The protocols provided are for reference purposes. Unsure if this reagent suits your experiment?

Need Industrial/Bulk Grade? [Request Custom Synthesis Quote](#)

BenchChem

Our mission is to be the trusted global source of essential and advanced chemicals, empowering scientists and researchers to drive progress in science and industry.

Contact

Address: 3281 E Guasti Rd
Ontario, CA 91761, United States
Phone: (601) 213-4426
Email: info@benchchem.com

[Contact our Ph.D. Support Team for a compatibility check](#)