

Cross-Validation of HB007's Mechanism of Action: A Comparative Guide

Author: BenchChem Technical Support Team. **Date:** April 2026

Compound of Interest

Compound Name: HB007
Cat. No.: B10828144

[Get Quote](#)

For Researchers, Scientists, and Drug Development Professionals

This guide provides a comparative analysis of the mechanism of action of **HB007**, a novel small-molecule degrader of the Small Ubiquitin-like Modifier 1 (SUMO1), with an alternative SUMOylation pathway inhibitor, TAK-981 (subasumstat). The information is supported by experimental data from publicly available research, with detailed methodologies for key experiments.

Introduction

SUMOylation is a critical post-translational modification process that regulates the function and stability of numerous proteins involved in essential cellular processes, including DNA repair, cell cycle progression, and signal transduction. Dysregulation of the SUMOylation pathway has been implicated in the pathogenesis of various cancers, making it an attractive target for therapeutic intervention. **HB007** and TAK-981 represent two distinct strategies to modulate this pathway for anti-cancer effects. **HB007** acts as a molecular glue to induce the degradation of SUMO1, while TAK-981 inhibits the SUMO-activating enzyme (SAE), the first step in the SUMOylation cascade.

Data Presentation: HB007 vs. TAK-981

The following tables summarize the key characteristics and available quantitative data for **HB007** and TAK-981. It is important to note that direct head-to-head comparative studies are limited; therefore, the data presented is compiled from individual studies and should be interpreted with caution.

Table 1: Mechanism of Action and Cellular Effects

Feature	HB007	TAK-981 (subasumstat)
Target	Induces degradation of SUMO1 protein[1]	Inhibits the SUMO-activating enzyme (SAE), blocking the entire SUMOylation cascade[2]
Mechanism	Acts as a molecular glue, binding to CAPRIN1 and inducing its interaction with the E3 ubiquitin ligase substrate receptor FBXO42. This complex then recruits, ubiquitinates, and targets SUMO1 for proteasomal degradation.[3]	Forms a covalent adduct with SUMO proteins when they are bound to the SAE, preventing the transfer of SUMO to downstream targets.[2]
Downstream Effects	- Reduction of StarD7 mRNA and protein levels. - Increased Endoplasmic Reticulum (ER) stress and Reactive Oxygen Species (ROS) production. - DeSUMOylation and degradation of the transcription factor TCF4.[4]	- Induction of a Type I Interferon (IFN-I) response. - Activation of innate and adaptive immune cells (T cells, NK cells, dendritic cells). - G2/M cell cycle arrest and mitotic defects in cancer cells.
Primary Mode of Action	Direct cytotoxic and cell-intrinsic effects on cancer cells.	Dual mechanism: direct anti-proliferative effects on cancer cells and activation of an anti-tumor immune response.

Table 2: In Vitro Potency (IC50 Values)

Cell Line	Cancer Type	HB007 (μM)	TAK-981 (nM)
LN229	Glioblastoma	Reported to inhibit cell growth in a concentration-dependent manner (0.1-100 μM)	Not Reported
Various Lymphoma Cell Lines	Lymphoma	Not Reported	IC50 values range from low nM to μM , with synergy observed with other agents.
Pancreatic Ductal Adenocarcinoma (PDAC) Cell Lines	Pancreatic Cancer	Not Reported	Potent inhibition in the nanomolar range.
Acute Myeloid Leukemia (AML) Cell Lines	Leukemia	Not Reported	Potent nanomolar activity, often stronger than standard-of-care cytarabine.

Note: The lack of directly comparable IC50 data in the same cell lines under identical experimental conditions makes a definitive potency comparison challenging.

Mandatory Visualization

Signaling Pathways and Experimental Workflows

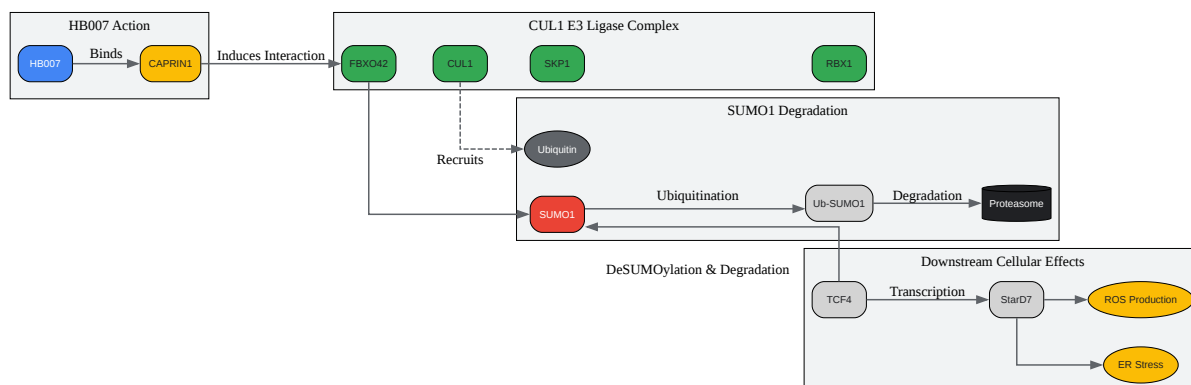

[Click to download full resolution via product page](#)

Caption: Mechanism of action of **HB007** leading to SUMO1 degradation and downstream effects.

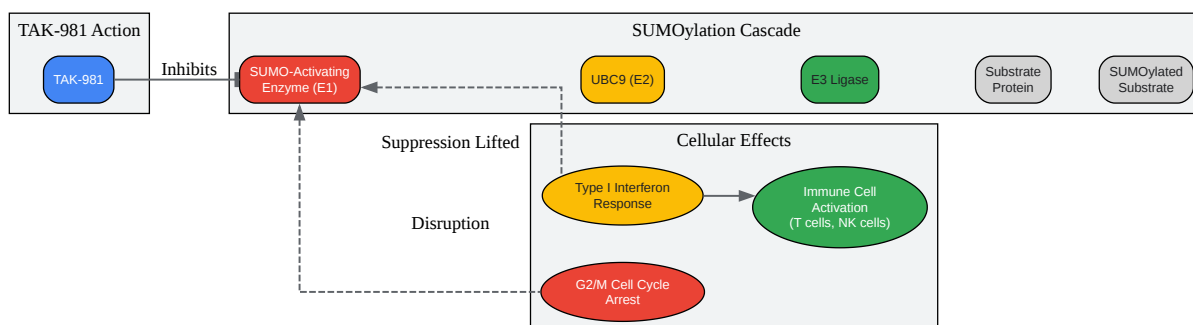

[Click to download full resolution via product page](#)

Caption: Mechanism of action of TAK-981, a SUMOylation inhibitor.

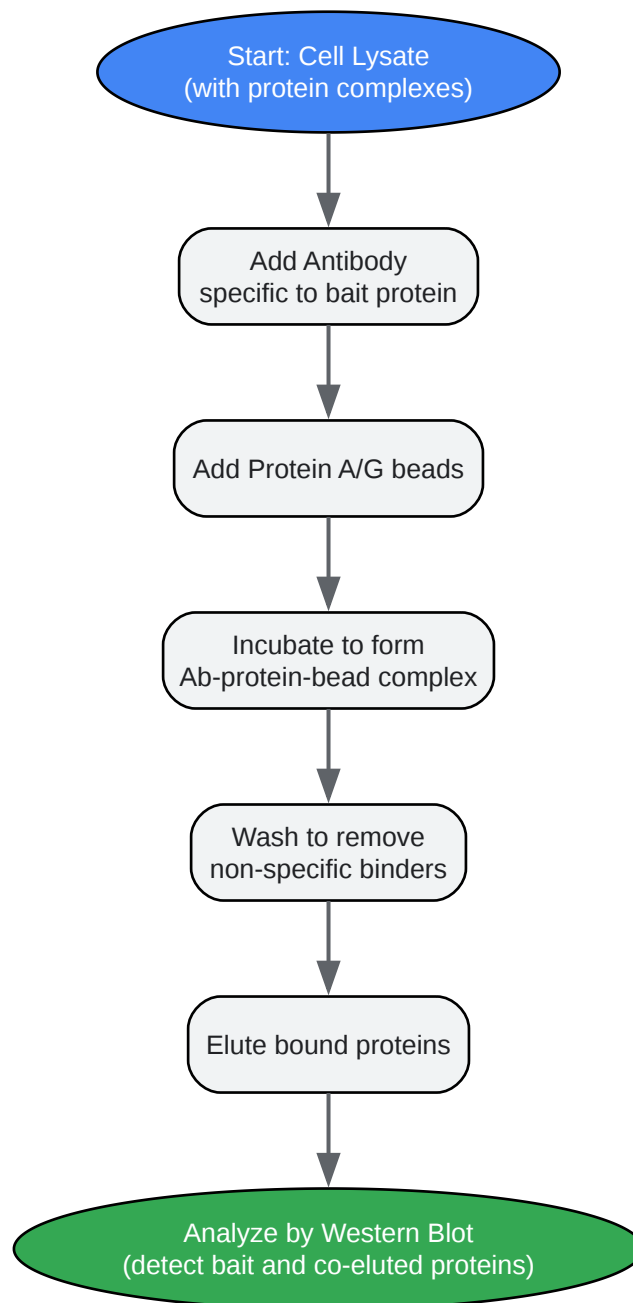

[Click to download full resolution via product page](#)

Caption: General workflow for a co-immunoprecipitation experiment.

Experimental Protocols

Cell Viability Assay (MTT Assay)

This protocol is used to assess the cytotoxic effects of compounds like **HB007** and TAK-981 on cancer cell lines.

Materials:

- 96-well plates
- Cancer cell lines of interest
- Complete cell culture medium
- MTT (3-(4,5-dimethylthiazol-2-yl)-2,5-diphenyltetrazolium bromide) solution (5 mg/mL in PBS)
- Solubilization solution (e.g., DMSO or 0.01 M HCl in 10% SDS)
- Microplate reader

Procedure:

- Seed cells in a 96-well plate at a density of 5,000-10,000 cells/well in 100 μ L of complete medium and incubate for 24 hours.
- Prepare serial dilutions of the test compounds (**HB007**, TAK-981) in culture medium.
- Remove the medium from the wells and add 100 μ L of the compound dilutions. Include a vehicle control (e.g., DMSO).
- Incubate the plate for the desired time period (e.g., 48 or 72 hours) at 37°C in a humidified CO₂ incubator.
- Add 10 μ L of MTT solution to each well and incubate for 3-4 hours at 37°C, allowing viable cells to convert MTT to formazan crystals.
- Add 100 μ L of solubilization solution to each well and mix thoroughly to dissolve the formazan crystals.
- Incubate the plate for an additional 4 hours or overnight at 37°C.
- Measure the absorbance at 570 nm using a microplate reader.

- Calculate the percentage of cell viability relative to the vehicle control and determine the IC50 value.

Western Blot for SUMO1 Degradation

This protocol is used to detect the levels of SUMO1 and other proteins in cell lysates after treatment with **HB007**.

Materials:

- Cell lysis buffer (e.g., RIPA buffer with protease and phosphatase inhibitors)
- Protein concentration assay kit (e.g., BCA assay)
- SDS-PAGE gels
- Transfer buffer
- PVDF or nitrocellulose membrane
- Blocking buffer (e.g., 5% non-fat milk or BSA in TBST)
- Primary antibodies (e.g., anti-SUMO1, anti-actin)
- HRP-conjugated secondary antibodies
- Chemiluminescent substrate
- Imaging system

Procedure:

- Treat cells with **HB007** or vehicle control for the desired time.
- Lyse the cells on ice and collect the supernatant after centrifugation.
- Determine the protein concentration of the lysates.
- Denature equal amounts of protein from each sample by boiling in Laemmli buffer.

- Separate the proteins by SDS-PAGE.
- Transfer the separated proteins to a PVDF or nitrocellulose membrane.
- Block the membrane with blocking buffer for 1 hour at room temperature.
- Incubate the membrane with the primary antibody (e.g., anti-SUMO1) overnight at 4°C.
- Wash the membrane with TBST and incubate with the appropriate HRP-conjugated secondary antibody for 1 hour at room temperature.
- Wash the membrane again with TBST.
- Add the chemiluminescent substrate and capture the signal using an imaging system.
- Re-probe the membrane with a loading control antibody (e.g., anti-actin) to ensure equal protein loading.

Co-Immunoprecipitation (Co-IP) for Protein-Protein Interactions

This protocol is used to validate the interaction between proteins, for example, CAPRIN1 and FBXO42, induced by **HB007**.

Materials:

- Co-IP lysis buffer (non-denaturing)
- Primary antibody for the "bait" protein (e.g., anti-CAPRIN1)
- Protein A/G magnetic beads or agarose resin
- Wash buffer
- Elution buffer
- Western blot reagents (as described above)

Procedure:

- Treat cells with **HB007** or vehicle control.
- Lyse the cells with a non-denaturing Co-IP lysis buffer.
- Pre-clear the lysate by incubating with beads to reduce non-specific binding.
- Incubate the pre-cleared lysate with the primary antibody against the bait protein overnight at 4°C.
- Add Protein A/G beads to the lysate and incubate for 2-4 hours to capture the antibody-protein complexes.
- Wash the beads several times with wash buffer to remove non-specific binders.
- Elute the bound proteins from the beads using elution buffer or by boiling in Laemmli buffer.
- Analyze the eluate by Western blot using antibodies against the bait protein (e.g., CAPRIN1) and the suspected interacting protein (e.g., FBXO42).

Conclusion

HB007 and TAK-981 represent two innovative and distinct approaches to targeting the SUMOylation pathway in cancer. **HB007**'s mechanism as a SUMO1 degrader offers a targeted approach to eliminate a key component of the SUMOylation machinery, leading to direct cancer cell cytotoxicity through ER stress and ROS production. In contrast, TAK-981's inhibition of the upstream SAE enzyme results in a broader blockade of SUMOylation and has a dual action of inducing cancer cell cycle arrest and potentially activating the host anti-tumor immune response. The choice between these strategies may depend on the specific cancer type, its dependency on SUMO1 versus the broader SUMOylation pathway, and the status of the patient's immune system. Further head-to-head comparative studies are warranted to fully elucidate the relative efficacy and potential clinical applications of these promising therapeutic agents.

Need Custom Synthesis?

BenchChem offers custom synthesis for rare earth carbides and specific isotopic labeling.

Email: info@benchchem.com or [Request Quote Online](#).

References

- [1. TAK-981, a SUMOylation inhibitor, suppresses AML growth immune-independently - PubMed \[pubmed.ncbi.nlm.nih.gov\]](#)
- [2. A small molecule SUMOylation inhibitor activates antitumor immune responses and potentiates immune therapies in preclinical models - PMC \[pmc.ncbi.nlm.nih.gov\]](#)
- [3. Inhibition of SUMOylation enhances DNA hypomethylating drug efficacy to reduce outgrowth of hematopoietic malignancies - PMC \[pmc.ncbi.nlm.nih.gov\]](#)
- [4. T cell-intrinsic immunomodulatory effects of TAK-981 \(subasumstat\), a SUMO-activating enzyme inhibitor, in chronic lymphocytic leukemia - PMC \[pmc.ncbi.nlm.nih.gov\]](#)
- [To cite this document: BenchChem. \[Cross-Validation of HB007's Mechanism of Action: A Comparative Guide\]. BenchChem, \[2026\]. \[Online PDF\]. Available at: \[https://www.benchchem.com/product/b10828144/docs#cross-validation-of-hb007-s-mechanism-of-action-a-comparative-guide\]](#)

Disclaimer & Data Validity:

The information provided in this document is for Research Use Only (RUO) and is strictly not intended for diagnostic or therapeutic procedures. While BenchChem strives to provide accurate protocols, we make no warranties, express or implied, regarding the fitness of this product for every specific experimental setup.

Technical Support: The protocols provided are for reference purposes. Unsure if this reagent suits your experiment?

Need Industrial/Bulk Grade? [Request Custom Synthesis Quote](#)

BenchChem

Our mission is to be the trusted global source of essential and advanced chemicals, empowering scientists and researchers to drive progress in science and industry.

Contact

Address: 3281 E Guasti Rd
Ontario, CA 91761, United States
Phone: (601) 213-4426
Email: info@benchchem.com

Contact our Ph.D. Support Team for a compatibility check