

An In-Depth Technical Guide to the Immunosuppressive Effects of Prodigiosin

Author: BenchChem Technical Support Team. **Date:** May 2026

Compound of Interest

Compound Name: *Prodigiosine*

Cat. No.: *B10828770*

[Get Quote](#)

For Researchers, Scientists, and Drug Development Professionals

Executive Summary

Prodigiosin, a red pigment produced by *Serratia marcescens* and other bacteria, has garnered significant scientific interest for its potent biological activities, including its profound immunosuppressive effects. This technical guide provides a comprehensive overview of the mechanisms underlying prodigiosin's ability to modulate immune responses, with a particular focus on its impact on T-cell activation and proliferation. This document summarizes key quantitative data, details relevant experimental protocols, and visualizes the intricate signaling pathways involved, offering a valuable resource for researchers and professionals in the field of immunology and drug development.

Introduction to Prodigiosin's Immunosuppressive Properties

Prodigiosin and its analogs are a family of tripyrrole red pigments that have demonstrated a range of therapeutic potentials, including anticancer, antimicrobial, and immunosuppressive activities.^{[1][2][3]} Notably, prodigiosin exhibits selective immunosuppressive effects, primarily

targeting T-lymphocytes, a crucial component of the adaptive immune system.[4][5] This targeted action, distinct from broader immunosuppressants, makes prodigiosin a compelling candidate for the development of novel therapies for autoimmune diseases and organ transplantation.[6][7]

Core Mechanism of Action: Inhibition of T-Cell Proliferation

The primary immunosuppressive effect of prodigiosin stems from its ability to inhibit the proliferation of T-cells.[5] Unlike some conventional immunosuppressants that block the production of interleukin-2 (IL-2), a key cytokine for T-cell proliferation, prodigiosin does not inhibit IL-2 secretion.[6] Instead, it disrupts the IL-2 signaling pathway by downregulating the expression of the IL-2 receptor alpha chain (IL-2R α or CD25).[6] This disruption of the IL-2/IL-2R signaling cascade is a central tenet of prodigiosin's mechanism of action.

Quantitative Data on Inhibition of Lymphocyte Proliferation

The inhibitory effects of prodigiosin on the proliferation of various immune and cancer cell lines have been quantified in numerous studies. The half-maximal inhibitory concentration (IC50) values vary depending on the cell type and experimental conditions.

Cell Line/Cell Type	Assay Type	IC50 Value	Reference
Human promyelocytic leukemia (HL-60)	MTT Assay	1.7 µg/mL	[8]
Human lung carcinoma (NCI-H292)	MTT Assay	3.6 µg/mL	[8]
Human epidermoid carcinoma (Hep-2)	MTT Assay	3.4 µg/mL	[8]
Human breast adenocarcinoma (MCF-7)	MTT Assay	5.1 µg/mL	[8]
Human lung carcinoma (A549)	MTT Assay	1.30 µg/mL	[4]
Human melanoma (A375)	MTT Assay	1.25 µg/mL	[4]
Human breast adenocarcinoma (MDA-MB-231)	MTT Assay	0.62 µg/mL	[4]
Human colon carcinoma (HCT116)	MTT Assay	0.70 µg/mL	[4]
Human hepatocellular carcinoma (HepG2)	MTT Assay	8.75 µg/mL (27 µM)	[9]
Human lung carcinoma (SK-LU-1)	MTT Assay	1.5 µg/mL (4.6 µM)	[9]
Human oral carcinoma (KB)	MTT Assay	< 4 µg/mL	[9]
B-cell chronic lymphocytic leukemia (B-CLL) cells	Cytotoxicity Assay	116 ± 25 nM	[1]

Modulation of Signaling Pathways

Prodigiosin exerts its immunosuppressive effects by modulating several key intracellular signaling pathways that are critical for immune cell activation, proliferation, and survival.

JAK/STAT Pathway

A primary target of prodigiosin is the Janus kinase/Signal Transducer and Activator of Transcription (JAK/STAT) pathway, particularly JAK3.^[10] JAK3 is predominantly expressed in hematopoietic cells and plays a crucial role in signal transduction from cytokine receptors, including the IL-2 receptor. By inhibiting the phosphorylation and activation of JAK3, prodigiosin effectively blocks downstream signaling events, including the phosphorylation of STAT proteins.

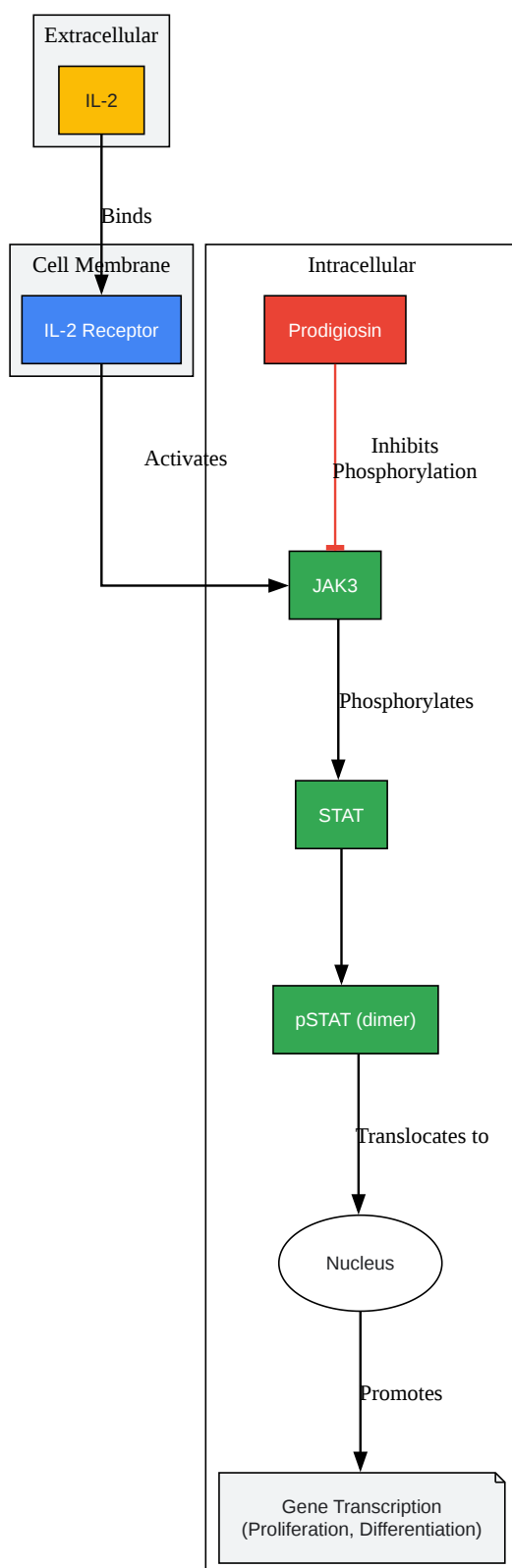

[Click to download full resolution via product page](#)

Figure 1: Prodigiosin's inhibition of the JAK/STAT signaling pathway.

MAPK and NF- κ B Pathways

Prodigiosin has also been shown to influence other critical signaling cascades, including the Mitogen-Activated Protein Kinase (MAPK) and Nuclear Factor-kappa B (NF- κ B) pathways. It can inhibit the phosphorylation of p38 MAPK and JNK, but not ERK1/2, in lipopolysaccharide (LPS)-activated macrophages. This inhibition correlates with reduced nitric oxide (NO) production. Furthermore, prodigiosin can decrease LPS-induced NF- κ B activity by preventing the degradation of its inhibitor, I κ B α .

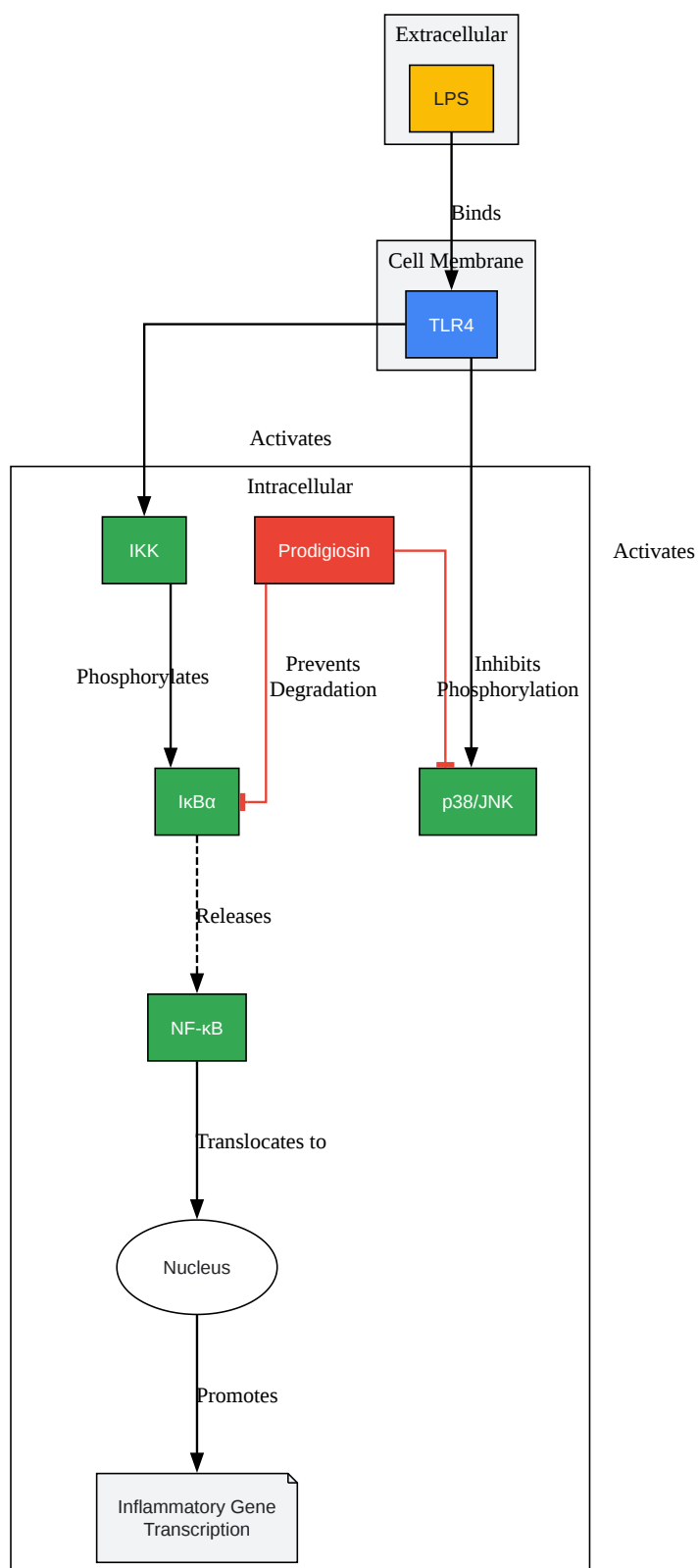

[Click to download full resolution via product page](#)

Figure 2: Prodigiosin's modulation of MAPK and NF-κB pathways.

Induction of Apoptosis in Immune Cells

Beyond inhibiting proliferation, prodigiosin also induces apoptosis, or programmed cell death, in various immune cells, including T-cells and B-cells.[1][6] This pro-apoptotic activity contributes significantly to its overall immunosuppressive effect. The induction of apoptosis is mediated through the activation of caspases, a family of proteases that are central to the apoptotic process.

Quantitative Data on Apoptosis Induction

Cell Line/Cell Type	Prodigiosin Concentration	Duration of Treatment	Apoptosis Induction	Reference
B-CLL cells	40-190 nM	24 hours	Dose-dependent increase	[6]
T-cells from B-CLL patients	40-190 nM	24 hours	Dose-dependent increase	[6]
Hep-2	3.4 µg/mL (IC50)	72 hours	80.5%	[11]
NCI-H292	3.4 µg/mL (IC50)	48 hours	60%	[11]

Effects on Cytokine Production

Prodigiosin exhibits a nuanced effect on cytokine production. While it does not inhibit the production of IL-2, it has been shown to suppress the secretion of pro-inflammatory cytokines such as interferon-gamma (IFN-γ) and IL-4 by activated T-cells.[6] In some contexts, it has been observed to elevate the levels of anti-inflammatory cytokines like IL-10 and IL-4.[12]

Experimental Protocols

This section provides detailed methodologies for key experiments cited in the study of prodigiosin's immunosuppressive effects.

T-Cell Proliferation Assay (MTT-based)

This protocol is adapted from methodologies used to assess the anti-proliferative effects of prodigiosin.[8][9]

Objective: To determine the effect of prodigiosin on the proliferation of T-lymphocytes stimulated with a mitogen like Concanavalin A (ConA).

Materials:

- T-lymphocytes (e.g., isolated from peripheral blood or a T-cell line like Jurkat)
- RPMI-1640 medium supplemented with 10% fetal bovine serum (FBS), penicillin (100 U/mL), and streptomycin (100 µg/mL)
- Prodigiosin stock solution (dissolved in DMSO)
- Concanavalin A (ConA)
- MTT (3-(4,5-dimethylthiazol-2-yl)-2,5-diphenyltetrazolium bromide) solution (5 mg/mL in PBS)
- DMSO
- 96-well microtiter plates
- CO2 incubator (37°C, 5% CO2)
- Microplate reader

Procedure:

- Seed T-cells into a 96-well plate at a density of 2×10^4 cells/well in 100 µL of complete RPMI-1640 medium.
- Incubate the plate for 24 hours at 37°C in a 5% CO2 incubator.
- Prepare serial dilutions of prodigiosin in complete medium. The final concentrations should typically range from 0.5 to 10 µg/mL.[9]
- Add 100 µL of the prodigiosin dilutions to the respective wells. For the control wells, add medium with the same concentration of DMSO used for the highest prodigiosin concentration.

- Add ConA to a final concentration of 5 µg/mL to all wells except for the unstimulated control.
- Incubate the plate for 72 hours at 37°C in a 5% CO₂ incubator.
- Add 20 µL of MTT solution to each well and incubate for an additional 4 hours.
- Carefully remove the medium and add 150 µL of DMSO to each well to dissolve the formazan crystals.
- Measure the absorbance at 570 nm using a microplate reader.
- Calculate the percentage of inhibition using the following formula: % Inhibition = [1 - (Absorbance of treated cells / Absorbance of control cells)] x 100

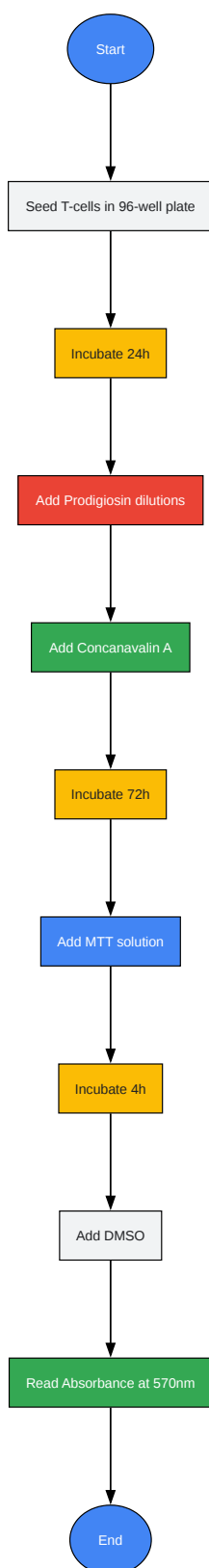

[Click to download full resolution via product page](#)

Figure 3: Workflow for the T-cell proliferation (MTT) assay.

Cytokine Quantification by ELISA

This protocol outlines a general sandwich ELISA procedure for measuring cytokine levels in cell culture supernatants.[\[12\]](#)[\[13\]](#)

Objective: To quantify the concentration of cytokines (e.g., IFN- γ , IL-2, IL-4, IL-10) in the supernatant of T-cells treated with prodigiosin.

Materials:

- ELISA plate pre-coated with capture antibody for the cytokine of interest
- Cell culture supernatants from T-cells treated with prodigiosin
- Recombinant cytokine standards
- Biotinylated detection antibody specific for the cytokine
- Streptavidin-HRP conjugate
- TMB (3,3',5,5'-Tetramethylbenzidine) substrate solution
- Stop solution (e.g., 2N H₂SO₄)
- Wash buffer (e.g., PBS with 0.05% Tween-20)
- Assay diluent (e.g., PBS with 1% BSA)
- Microplate reader

Procedure:

- Prepare serial dilutions of the recombinant cytokine standard in assay diluent.
- Add 100 μ L of standards and cell culture supernatants to the wells of the ELISA plate.
- Incubate for 2 hours at room temperature.
- Wash the plate three times with wash buffer.

- Add 100 μ L of the biotinylated detection antibody to each well and incubate for 1 hour at room temperature.
- Wash the plate three times with wash buffer.
- Add 100 μ L of Streptavidin-HRP conjugate to each well and incubate for 30 minutes at room temperature in the dark.
- Wash the plate five times with wash buffer.
- Add 100 μ L of TMB substrate solution to each well and incubate for 15-30 minutes at room temperature in the dark.
- Add 50 μ L of stop solution to each well.
- Read the absorbance at 450 nm within 30 minutes.
- Generate a standard curve by plotting the absorbance values of the standards against their known concentrations and determine the cytokine concentrations in the samples.

Western Blot Analysis of Signaling Proteins

This protocol provides a general framework for analyzing the phosphorylation status of proteins in the JAK/STAT, MAPK, and NF- κ B pathways.

Objective: To detect changes in the phosphorylation of key signaling proteins (e.g., JAK3, STAT3, p38, JNK, I κ B α) in immune cells treated with prodigiosin.

Materials:

- Immune cells (e.g., T-cells, macrophages)
- Prodigiosin
- Stimulating agent (e.g., IL-2, LPS)
- Lysis buffer (e.g., RIPA buffer with protease and phosphatase inhibitors)
- Protein assay kit (e.g., BCA assay)

- SDS-PAGE gels
- Transfer buffer
- PVDF or nitrocellulose membranes
- Blocking buffer (e.g., 5% non-fat milk or BSA in TBST)
- Primary antibodies (specific for total and phosphorylated forms of the target proteins)
- HRP-conjugated secondary antibody
- ECL (Enhanced Chemiluminescence) detection reagent
- Chemiluminescence imaging system

Procedure:

- Treat immune cells with prodigiosin for the desired time and concentration, followed by stimulation with the appropriate agent (e.g., IL-2 for JAK/STAT, LPS for MAPK/NF- κ B).
- Lyse the cells in lysis buffer and quantify the protein concentration.
- Denature equal amounts of protein by boiling in Laemmli sample buffer.
- Separate the proteins by SDS-PAGE and transfer them to a membrane.
- Block the membrane with blocking buffer for 1 hour at room temperature.
- Incubate the membrane with the primary antibody (diluted in blocking buffer) overnight at 4°C. Use antibodies specific for the phosphorylated and total forms of the protein of interest (e.g., anti-phospho-JAK3, anti-JAK3).
- Wash the membrane three times with TBST.
- Incubate the membrane with the HRP-conjugated secondary antibody for 1 hour at room temperature.
- Wash the membrane three times with TBST.

- Apply ECL detection reagent and visualize the protein bands using a chemiluminescence imaging system.
- Quantify the band intensities and normalize the phosphorylated protein levels to the total protein levels.

Conclusion

Prodigiosin demonstrates significant immunosuppressive properties, primarily through the targeted inhibition of T-cell proliferation and the induction of apoptosis in immune cells. Its unique mechanism of action, centered on the disruption of the IL-2/IL-2R signaling pathway via the inhibition of JAK3, and its modulation of the MAPK and NF- κ B pathways, distinguishes it from many existing immunosuppressive agents. The quantitative data and detailed experimental protocols provided in this guide offer a solid foundation for further research into the therapeutic potential of prodigiosin for a range of immune-related disorders. Continued investigation into its precise molecular interactions and in vivo efficacy is warranted to fully realize its clinical promise.

Need Custom Synthesis?

BenchChem offers custom synthesis for rare earth carbides and specific isotopic labeling.

Email: info@benchchem.com or [Request Quote Online](#).

References

- [1. researchgate.net \[researchgate.net\]](#)
- [2. Monitor NF- \$\kappa\$ B activation with dual luciferase reporter assay on SpectraMax iD5 \[moleculardevices.com\]](#)
- [3. Frontiers | Microbial prodigiosin shows broad-spectrum bioactivity confirmed by experimental and computational analyses \[frontiersin.org\]](#)
- [4. Protocol for Apoptosis Assay by Flow Cytometry Using Annexin V Staining Method - PubMed \[pubmed.ncbi.nlm.nih.gov\]](#)
- [5. T-cell specific immunosuppression by prodigiosin isolated from Serratia marcescens - PubMed \[pubmed.ncbi.nlm.nih.gov\]](#)

- 6. Protocol for Apoptosis Assay by Flow Cytometry Using Annexin V Staining Method - PMC [[pmc.ncbi.nlm.nih.gov](https://pubmed.ncbi.nlm.nih.gov/)]
- 7. [tandfonline.com](https://www.tandfonline.com) [[tandfonline.com](https://www.tandfonline.com)]
- 8. Antiproliferative Activity of Prodigiosin Derived From *Serratia marcescens* VITSD2: An In Vitro and In Silico Approach - PMC [[pmc.ncbi.nlm.nih.gov](https://pubmed.ncbi.nlm.nih.gov/)]
- 9. Study on the Anticancer Activity of Prodigiosin from Variants of *Serratia Marcescens* QBN VTCC 910026 - PMC [[pmc.ncbi.nlm.nih.gov](https://pubmed.ncbi.nlm.nih.gov/)]
- 10. [promega.com](https://www.promega.com) [[promega.com](https://www.promega.com)]
- 11. Cytotoxic Effect of Prodigiosin, Natural Red Pigment, Isolated from *Serratia marcescens* UFPEDA 398 - PMC [[pmc.ncbi.nlm.nih.gov](https://pubmed.ncbi.nlm.nih.gov/)]
- 12. Anticancer and Immunomodulatory Activities of Prodigiosin Extracted and Purified from *Serratia marcescens* - PMC [[pmc.ncbi.nlm.nih.gov](https://pubmed.ncbi.nlm.nih.gov/)]
- 13. [biomatik.com](https://www.biomatik.com) [[biomatik.com](https://www.biomatik.com)]
- To cite this document: BenchChem. [An In-Depth Technical Guide to the Immunosuppressive Effects of Prodigiosin]. BenchChem, [2026]. [Online PDF]. Available at: [<https://www.benchchem.com/product/b10828770/docs#an-in-depth-technical-guide-to-the-immunosuppressive-effects-of-prodigiosin>]

Disclaimer & Data Validity:

The information provided in this document is for Research Use Only (RUO) and is strictly not intended for diagnostic or therapeutic procedures. While BenchChem strives to provide accurate protocols, we make no warranties, express or implied, regarding the fitness of this product for every specific experimental setup.

Technical Support: The protocols provided are for reference purposes. Unsure if this reagent suits your experiment?

Need Industrial/Bulk Grade? [Request Custom Synthesis Quote](#)

BenchChem

Our mission is to be the trusted global source of essential and advanced chemicals, empowering scientists and researchers to drive progress in science and industry.

Contact

Address: 3281 E Guasti Rd

Ontario, CA 91761, United States

Phone: (601) 213-4426

Email: info@benchchem.com

[Contact our Ph.D. Support Team for a compatibility check](#)