

Addressing poor oral bioavailability of A-86929

Author: BenchChem Technical Support Team. **Date:** April 2026

Compound of Interest

Compound Name:	A-86929
CAS No.:	173934-91-3
Cat. No.:	B10827049

[Get Quote](#)

Technical Support Center: A-86929

This technical support center provides troubleshooting guides and frequently asked questions (FAQs) for researchers, scientists, and drug development professionals working with the selective dopamine D1 receptor agonist, **A-86929**. The primary focus is to address the well-documented challenge of its poor oral bioavailability.

Frequently Asked Questions (FAQs)

Q1: We are observing very low plasma concentrations of **A-86929** after oral administration in our animal models. Is this expected?

A1: Yes, this is a known characteristic of **A-86929**. The compound has inherently poor oral bioavailability. Studies have shown that its prodrug, adrogolide (ABT-431), also exhibits low oral bioavailability, in the range of approximately 4% in humans, due to extensive first-pass metabolism in the liver.^{[1][2][3]} Therefore, low systemic exposure after oral dosing is an expected outcome.

Q2: What is the primary reason for the poor oral bioavailability of **A-86929**?

A2: The principal cause of **A-86929**'s poor oral bioavailability is extensive presystemic metabolism, specifically a high hepatic "first-pass" effect.[1][2][3] After absorption from the gastrointestinal tract, the drug passes through the liver, where it is heavily metabolized before it can reach systemic circulation. While solubility and permeability can also influence oral bioavailability, the primary limiting factor for **A-86929** is its rapid metabolic clearance.

Q3: What is adrogolide (ABT-431) and does it solve the oral bioavailability issue?

A3: Adrogolide (ABT-431) is a diacetyl prodrug of **A-86929**. [4][5] It was developed to improve the chemical stability of **A-86929**. [4] While it is rapidly converted back to the active parent compound, **A-86929**, in plasma (with a half-life of less than 1 minute), it does not fully overcome the issue of poor oral bioavailability. [4] Clinical data indicates that adrogolide still has a low oral bioavailability of around 4% in humans due to the extensive first-pass metabolism of the parent compound. [1][2][3]

Q4: Are there alternative routes of administration that have been explored for **A-86929** or its prodrug?

A4: Yes, to bypass the extensive first-pass metabolism associated with oral administration, other routes have been investigated. Subcutaneous (s.c.) and intravenous (i.v.) administrations have been used in preclinical and clinical studies to achieve therapeutic plasma concentrations. [1][4] Furthermore, oral inhalation formulations have been explored as a potential strategy to significantly increase the bioavailability of adrogolide. [1][2]

Troubleshooting Guide

Issue: Consistently low and variable plasma concentrations of **A-86929** in preclinical oral dosing studies.

This guide provides a systematic approach to troubleshoot and potentially enhance the oral bioavailability of **A-86929** in your experimental setting.

The first step is to establish a baseline pharmacokinetic profile of **A-86929** in your chosen animal model.

Experimental Protocol: Single-Dose Pharmacokinetic Study in Rats

- Animal Model: Male Sprague-Dawley rats (n=3-5 per group).
- Formulation: Prepare a simple suspension of **A-86929** in a vehicle such as 0.5% methylcellulose.
- Dosing:
 - Oral (p.o.): Administer a single oral gavage dose (e.g., 10 mg/kg).
 - Intravenous (i.v.): Administer a single bolus intravenous dose (e.g., 1 mg/kg) via the tail vein to determine absolute bioavailability.
- Blood Sampling: Collect serial blood samples (e.g., at 0.25, 0.5, 1, 2, 4, 6, 8, and 24 hours post-dose) into tubes containing an appropriate anticoagulant.
- Plasma Processing: Centrifuge the blood samples to separate plasma and store at -80°C until analysis.
- Bioanalysis: Quantify the concentration of **A-86929** in plasma samples using a validated LC-MS/MS method.
- Data Analysis: Calculate key pharmacokinetic parameters such as C_{max}, T_{max}, AUC, and oral bioavailability (F%).

To confirm that extensive metabolism is the primary issue, in vitro assays are recommended.

Experimental Protocol: In Vitro Metabolic Stability in Liver Microsomes

- System: Use liver microsomes from the same species as your animal model (e.g., rat, mouse, or human).
- Incubation: Incubate **A-86929** at a known concentration with the liver microsomes in the presence of NADPH (a necessary cofactor for many metabolic enzymes).
- Time Points: Take samples at various time points (e.g., 0, 5, 15, 30, and 60 minutes).

- Analysis: Quench the reaction and analyze the remaining concentration of **A-86929** at each time point by LC-MS/MS.
- Calculation: Determine the in vitro half-life ($t_{1/2}$) and intrinsic clearance (Cl_{int}). A short half-life and high clearance would support the hypothesis of high first-pass metabolism.

Experimental Protocol: Caco-2 Permeability Assay

- Cell Culture: Culture Caco-2 cells on permeable supports until they form a confluent monolayer, which serves as a model of the intestinal epithelium.
- Transport Study: Add **A-86929** to the apical (AP) side and measure its appearance on the basolateral (BL) side over time to determine the apparent permeability coefficient (P_{app}). A high P_{app} value suggests good membrane permeation.[6]

Based on the understanding that high first-pass metabolism is the key issue, the following formulation strategies can be explored to improve the oral bioavailability of **A-86929**. [7][8][9]

- Lipid-Based Formulations:
 - Self-Emulsifying Drug Delivery Systems (SEDDS): These are isotropic mixtures of oils, surfactants, and cosolvents that form fine oil-in-water emulsions upon gentle agitation in aqueous media, such as the gastrointestinal fluids.[7][10] SEDDS can enhance lymphatic transport, which can partially bypass the liver and reduce first-pass metabolism.
 - Solid Lipid Nanoparticles (SLNs): These are colloidal carriers that can also promote lymphatic uptake.[9]
- Nanotechnology-Based Approaches:
 - Nanoparticles: Encapsulating **A-86929** in nanoparticles can protect it from degradation in the gastrointestinal tract and potentially alter its absorption pathway, directing more of the drug into the lymphatic system.[8]
- Inhibition of Metabolic Enzymes:

- Co-administration with a Cytochrome P450 Inhibitor: While not a formulation strategy per se, co-administering **A-86929** with a known inhibitor of the specific CYP450 enzymes responsible for its metabolism can be used as a tool to confirm the extent of first-pass metabolism in preclinical models. This approach is generally not viable for therapeutic use due to the risk of drug-drug interactions.

Data Presentation

Table 1: Hypothetical Pharmacokinetic Parameters of **A-86929** in Rats Following a Single Dose

Parameter	Oral Administration (10 mg/kg)	Intravenous Administration (1 mg/kg)
Cmax (ng/mL)	50 ± 15	500 ± 75
Tmax (h)	0.5 ± 0.2	0.1 ± 0.05
AUC (0-t) (ng*h/mL)	150 ± 40	750 ± 100
Oral Bioavailability (F%)	~4%	-

Note: This table presents hypothetical data for illustrative purposes.

Visualizations

Signaling and Metabolic Considerations

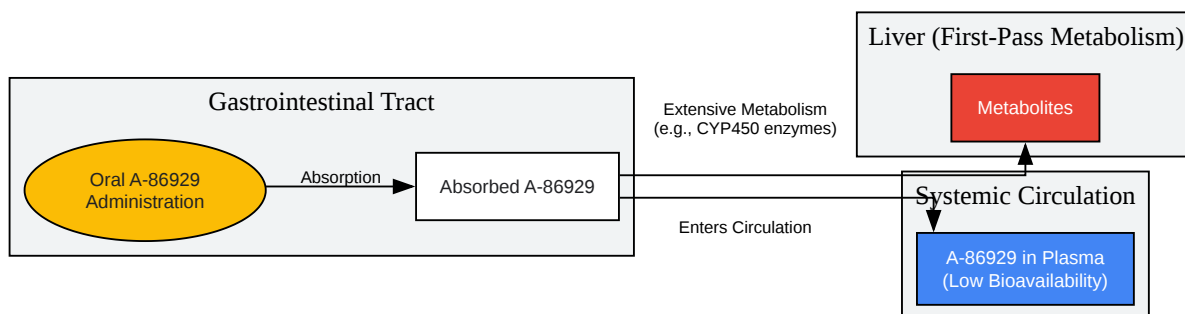

[Click to download full resolution via product page](#)

Caption: First-pass metabolism of **A-86929**.

Experimental Workflow

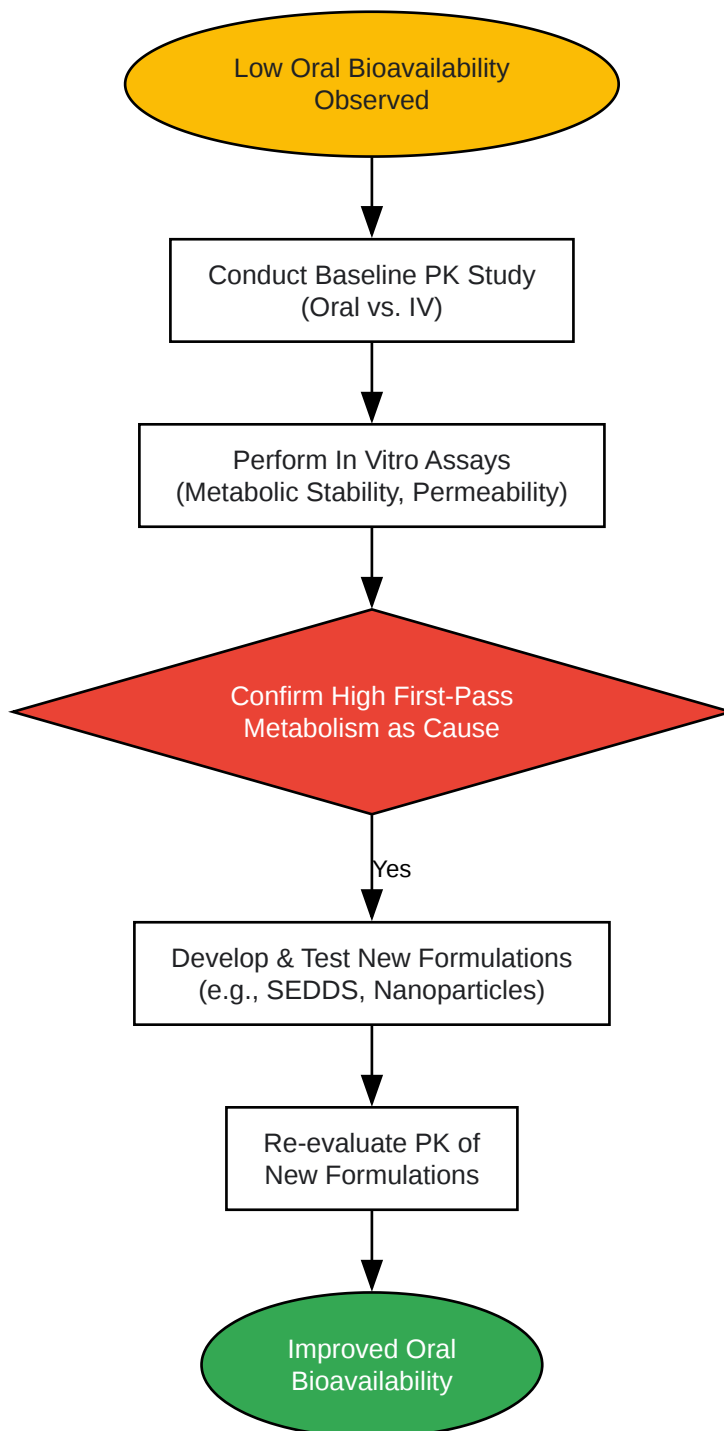

[Click to download full resolution via product page](#)

Caption: Troubleshooting workflow for **A-86929**.

Logical Relationships in Formulation Strategy

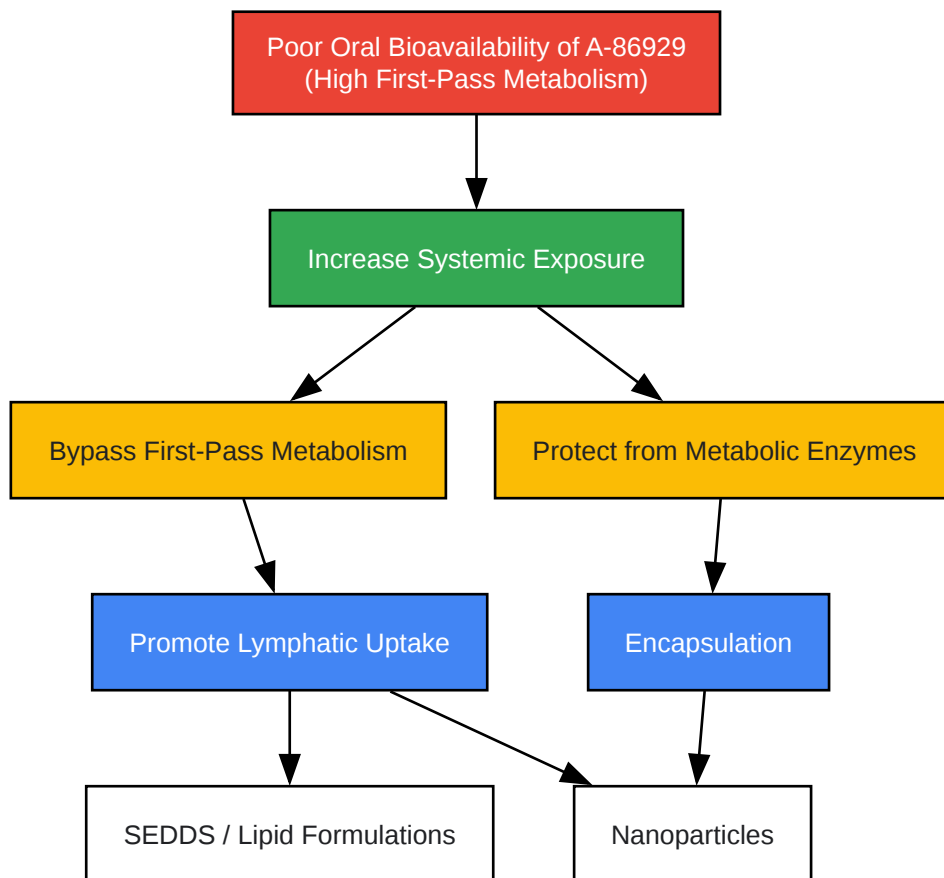

[Click to download full resolution via product page](#)

Caption: Formulation strategies for **A-86929**.

Need Custom Synthesis?

BenchChem offers custom synthesis for rare earth carbides and specific isotopic labeling.

Email: info@benchchem.com or [Request Quote Online](#).

References

- 1. [researchgate.net](https://www.researchgate.net) [researchgate.net]
- 2. The Discovery of Novel Selective D1 Dopaminergic Agonists: A-68930, A-77636, A-86929, and ABT-413 - PMC [pmc.ncbi.nlm.nih.gov]

- [3. Adrogolide HCl \(ABT-431; DAS-431\), a prodrug of the dopamine D1 receptor agonist, A-86929: preclinical pharmacology and clinical data - PubMed \[pubmed.ncbi.nlm.nih.gov\]](#)
- [4. ABT-431: the diacetyl prodrug of A-86929, a potent and selective dopamine D1 receptor agonist: in vitro characterization and effects in animal models of Parkinson's disease - PubMed \[pubmed.ncbi.nlm.nih.gov\]](#)
- [5. A-86929 - Wikipedia \[en.wikipedia.org\]](#)
- [6. Prediction of the human oral bioavailability by using in vitro and in silico drug related parameters in a physiologically based absorption model - PubMed \[pubmed.ncbi.nlm.nih.gov\]](#)
- [7. hilarispublisher.com \[hilarispublisher.com\]](#)
- [8. hilarispublisher.com \[hilarispublisher.com\]](#)
- [9. Formulation Strategies to Improve the Bioavailability of Poorly Absorbed Drugs with Special Emphasis on Self-Emulsifying Systems - PMC \[pmc.ncbi.nlm.nih.gov\]](#)
- [10. \[PDF\] Formulation Strategies to Improve the Bioavailability of Poorly Absorbed Drugs with Special Emphasis on Self-Emulsifying Systems | Semantic Scholar \[semanticscholar.org\]](#)
- [To cite this document: BenchChem. \[Addressing poor oral bioavailability of A-86929\]. BenchChem, \[2026\]. \[Online PDF\]. Available at: \[https://www.benchchem.com/product/b10827049/docs#addressing-poor-oral-bioavailability-of-a-86929\]](#)

Disclaimer & Data Validity:

The information provided in this document is for Research Use Only (RUO) and is strictly not intended for diagnostic or therapeutic procedures. While BenchChem strives to provide accurate protocols, we make no warranties, express or implied, regarding the fitness of this product for every specific experimental setup.

Technical Support: The protocols provided are for reference purposes. Unsure if this reagent suits your experiment?

Need Industrial/Bulk Grade? [Request Custom Synthesis Quote](#)

BenchChem

Our mission is to be the trusted global source of essential and advanced chemicals, empowering scientists and researchers to drive progress in science and industry.

Contact

Address: 3281 E Guasti Rd

Ontario, CA 91761, United States

Phone: (601) 213-4426

Email: info@benchchem.com

[Contact our Ph.D. Support Team for a compatibility check](#)