

# Ac-FLTD-CMK Administration Protocol for In Vivo Mouse Models[1]

**Author:** BenchChem Technical Support Team. **Date:** April 2026

## Compound of Interest

Compound Name: Ac-FLTD-CMK (trifluoroacetate salt)

Cat. No.: B10827309

[Get Quote](#)

## Executive Summary & Scientific Rationale

Ac-FLTD-CMK (N-acetyl-Phe-Leu-Thr-Asp-chloromethylketone) is a potent, irreversible inhibitor designed to mimic the cleavage site of Gasdermin D (GSDMD), the executioner pore-forming protein of pyroptosis.[1]

While often categorized broadly as a Caspase-1 inhibitor, its scientific utility lies in its specific design based on the human GSDMD cleavage motif (FLTD). It inhibits inflammatory caspases (Caspase-1, -4, -5, and -11) by covalently binding to their catalytic cysteine residues, thereby preventing the cleavage of GSDMD into its active N-terminal fragment (GSDMD-N).

## Critical Species-Specific Considerations (Expertise & Integrity)

Before proceeding with in vivo mouse experiments, researchers must acknowledge a critical structural distinction:

- Human GSDMD Cleavage Site:272-FLTD-275[2]

- Mouse GSDMD Cleavage Site:273-LLSD-276[1][2]

Although Ac-FLTD-CMK is derived from the human sequence, it cross-reacts with murine Caspase-1 and Caspase-11 (the ortholog of human Caspase-4/5) at sufficient concentrations (IC<sub>50</sub> ~46.7 nM for Casp-1; ~10 μM for murine Casp-11). However, for strictly mouse-centric studies, the analog Z-LLSD-FMK is the species-specific equivalent. Ac-FLTD-CMK is best utilized in models where human translational relevance is being tested or when broad inflammatory caspase inhibition is required beyond simple Caspase-1 blockade (which Z-YVAD-FMK provides).

## Mechanism of Action

The following diagram illustrates the intervention point of Ac-FLTD-CMK within the pyroptosis signaling cascade.

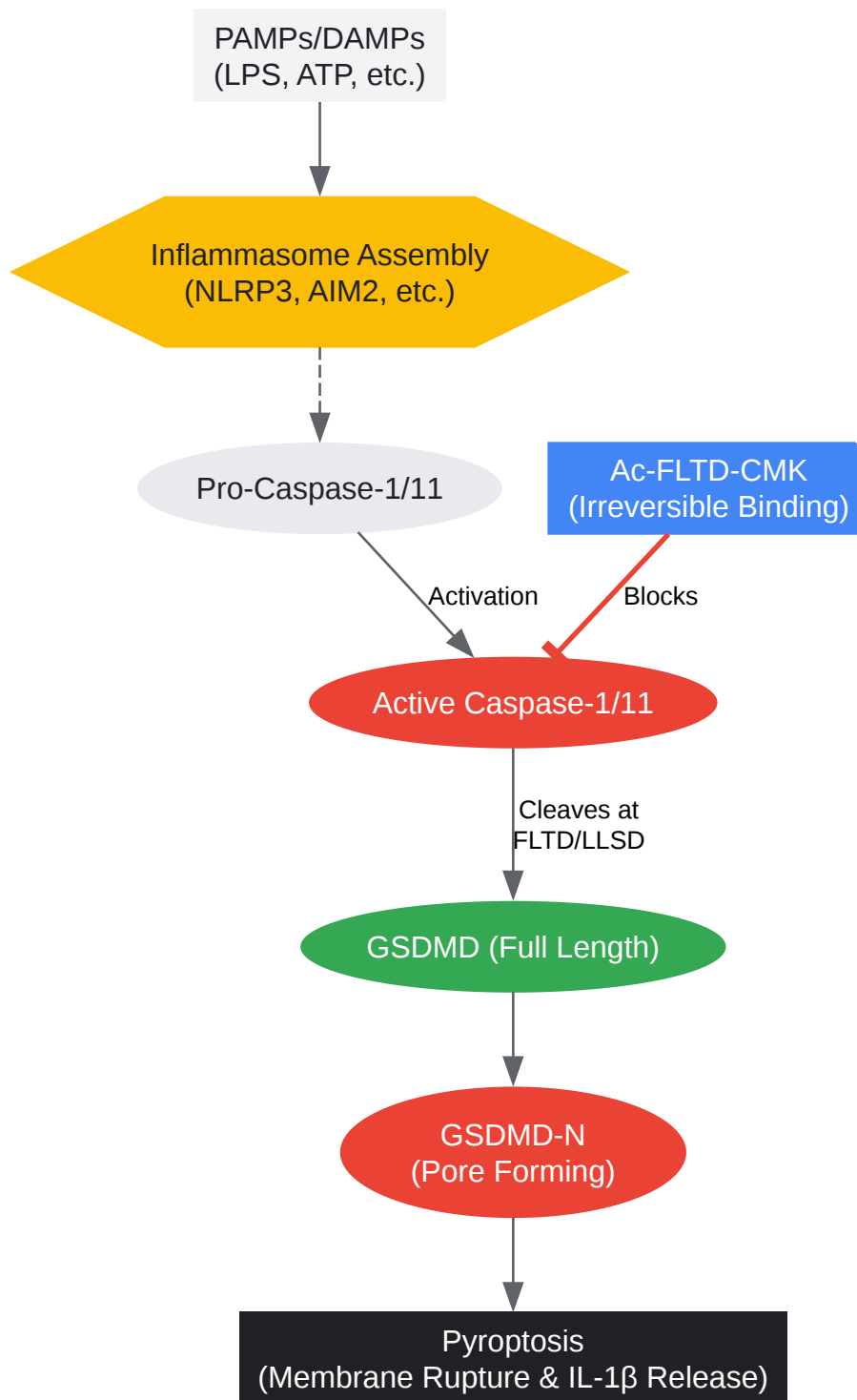

[Click to download full resolution via product page](#)

Caption: Ac-FLTD-CMK covalently binds active inflammatory caspases, preventing GSDMD cleavage and subsequent pyroptosis.

## Pre-Clinical Formulation & Solubility

Chloromethylketone (CMK) peptides are hydrophobic and prone to precipitation in aqueous buffers. Proper vehicle formulation is non-negotiable for consistent in vivo bioavailability.

### Stock Solution (In Vitro / Storage)

- Solvent: 100% DMSO (anhydrous).
- Concentration: 10 mM or 20 mg/mL.
- Storage: Aliquot and store at -80°C. Avoid freeze-thaw cycles.

### In Vivo Working Solution (Systemic Administration)

Target Concentration: 1.0 – 2.5 mg/mL (depending on dose). Stability: Prepare freshly immediately before injection. Do not store the working solution.

Component	Volume Fraction	Preparation Order (CRITICAL)
1. Stock in DMSO	10%	Dissolve peptide fully in DMSO first.
2. PEG300	40%	Add PEG300 to the DMSO solution; vortex until clear.
3. Tween 80	5%	Add Tween 80; vortex thoroughly.
4. Saline (0.9%)	45%	Add Saline last while vortexing.



*Note: If precipitation occurs upon adding saline, warm the solution to 37°C and sonicate briefly. If the solution remains cloudy, do not inject IV; IP is permissible but absorption may be variable.*

---

## Experimental Protocols

### Protocol A: Systemic Administration (Intraperitoneal - IP)

Recommended for systemic inflammation models (e.g., Sepsis, Endotoxemia, Liver Failure).

- Animal Model: C57BL/6 Mice (Age 8-12 weeks).
- Dose Range: 5 mg/kg – 10 mg/kg.
  - Rationalization: Related GSDME-derived CMK inhibitors show efficacy at 5 mg/kg IP daily. [\[3\]](#)
- Frequency: Daily (q.d.) or Single Bolus (depending on model duration).

#### Step-by-Step:

- Weigh Mice: Calculate individual injection volumes.
  - Example: For a 25g mouse at 10 mg/kg dose using a 2 mg/mL solution:
- Preparation: Prepare the Working Solution as per Section 3. Maintain at room temperature.
- Restraint: Secure the mouse using the scruff method to expose the abdomen.
- Injection: Using a 27G needle, inject into the lower right quadrant of the abdomen to avoid the cecum/bladder.

- Monitoring: Monitor for signs of peritonitis or distress (hunching) due to the vehicle (DMSO/PEG).

## Protocol B: Local Administration (Intracerebroventricular - ICV)

Validated for Neuroinflammation/TBI models (Source: NeuroReport 2021).

- Dose: 10 µg per mouse (approximate, based on standard ICV volumes of 1-2 µL).
- Vehicle: Modified artificial CSF (aCSF) with <1% DMSO (requires high concentration stock).

Step-by-Step:

- Anesthesia: Induce with isoflurane (3-4%) and maintain (1.5-2%).
- Stereotaxic Fixation: Secure head; expose skull.
- Coordinates: AP -0.8 mm, ML -1.5 mm, DV -3.5 mm (relative to Bregma).
- Injection: Infuse slowly (0.5 µL/min) using a Hamilton syringe. Leave needle in place for 5 mins to prevent backflow.
- Timing: Administer 30 minutes post-injury (e.g., TBI) for neuroprotection.[\[4\]](#)

## Validation & Readouts

To confirm Ac-FLTD-CMK efficacy, you must demonstrate the inhibition of GSDMD cleavage, not just the reduction of downstream cytokines.

## Western Blotting (The Gold Standard)

- Tissue: Liver, Spleen, or Brain lysate.
- Target:GSDMD-N (Active fragment) vs. GSDMD-FL (Full length).
- Expected Result: A reduction in the ~30 kDa GSDMD-N band intensity compared to Vehicle-treated controls.

- Antibody Note: Ensure the antibody recognizes the N-terminal domain of murine GSDMD.

## ELISA

- Target: IL-1 $\beta$  and IL-18 (Serum or Tissue Homogenate).
- Expected Result: Significant reduction in cytokine levels.[\[4\]](#)[\[5\]](#)[\[6\]](#)[\[7\]](#)
- Control: TNF- $\alpha$  (Should be less affected if the effect is specific to pyroptosis/inflammasome, though cross-talk exists).

## LDH Release Assay

- Sample: Serum or Cell Culture Supernatant (ex vivo).
- Mechanism: Pyroptosis causes membrane rupture, releasing LDH. Ac-FLTD-CMK should reduce LDH levels.

## Experimental Workflow Diagram

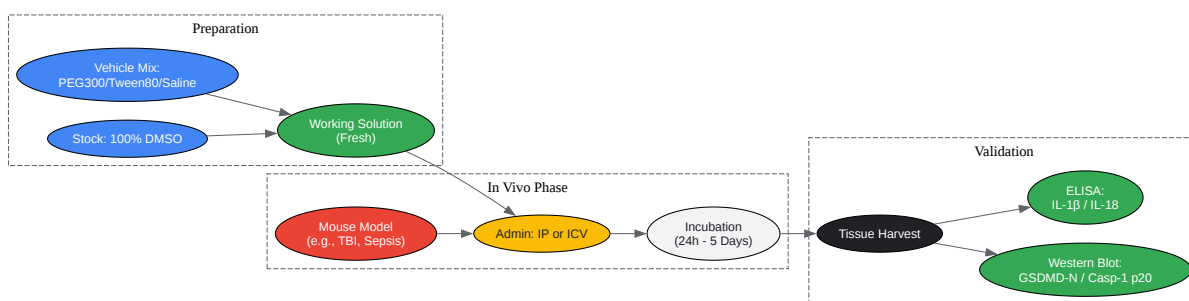

[Click to download full resolution via product page](#)

Caption: Operational workflow for Ac-FLTD-CMK preparation, administration, and downstream validation.

## References

- Yang, J., et al. (2018).<sup>[1][8]</sup> Mechanism of gasdermin D recognition by inflammatory caspases and their inhibition by a gasdermin D-derived peptide inhibitor.<sup>[6][8][9]</sup> Proceedings of the National Academy of Sciences (PNAS).
- Gao, J., et al. (2021). Ac-FLTD-CMK inhibits pyroptosis and exerts neuroprotective effect in a mice model of traumatic brain injury.<sup>[4]</sup> NeuroReport.
- Li, Y., et al. (2023). Inhibition of GSDMD activation by Z-LLSD-FMK or Z-YVAD-FMK reduces vascular inflammation and atherosclerotic lesion development in ApoE<sup>-/-</sup> mice.<sup>[1][2]</sup> Frontiers in Pharmacology.
- Zhou, B., et al. (2020). Gasdermin E-derived caspase-3 inhibitors effectively protect mice from acute hepatic failure. Cell Death & Disease. (Provides protocol basis for GSDM-derived CMK inhibitors).

### Need Custom Synthesis?

BenchChem offers custom synthesis for rare earth carbides and specific isotopic labeling.

Email: [info@benchchem.com](mailto:info@benchchem.com) or [Request Quote Online](#).

## Sources

- 1. [Frontiers | Inhibition of GSDMD activation by Z-LLSD-FMK or Z-YVAD-FMK reduces vascular inflammation and atherosclerotic lesion development in ApoE<sup>-/-</sup> mice \[frontiersin.org\]](#)
- 2. [Inhibition of GSDMD activation by Z-LLSD-FMK or Z-YVAD-FMK reduces vascular inflammation and atherosclerotic lesion development in ApoE<sup>-/-</sup> mice - PMC \[pmc.ncbi.nlm.nih.gov\]](#)

- [3. Gasdermin E-derived caspase-3 inhibitors effectively protect mice from acute hepatic failure - PMC \[pmc.ncbi.nlm.nih.gov\]](#)
- [4. Ac-FLTD-CMK inhibits pyroptosis and exerts neuroprotective effect in a mice model of traumatic brain injury - PubMed \[pubmed.ncbi.nlm.nih.gov\]](#)
- [5. Frontiers | Role of pyroptosis in hemostasis activation in sepsis \[frontiersin.org\]](#)
- [6. pubs.rsc.org \[pubs.rsc.org\]](#)
- [7. Applying caspase-1 inhibitors for inflammasome assays in human whole blood - PubMed \[pubmed.ncbi.nlm.nih.gov\]](#)
- [8. immune-system-research.com \[immune-system-research.com\]](#)
- [9. medchemexpress.com \[medchemexpress.com\]](#)
- To cite this document: BenchChem. [Ac-FLTD-CMK Administration Protocol for In Vivo Mouse Models[1]]. BenchChem, [2026]. [Online PDF]. Available at: [\[https://www.benchchem.com/product/b10827309/docs#ac-fltd-cmk-administration-protocol-for-in-vivo-mouse-models-1\]](https://www.benchchem.com/product/b10827309/docs#ac-fltd-cmk-administration-protocol-for-in-vivo-mouse-models-1)

---

### Disclaimer & Data Validity:

The information provided in this document is for Research Use Only (RUO) and is strictly not intended for diagnostic or therapeutic procedures. While BenchChem strives to provide accurate protocols, we make no warranties, express or implied, regarding the fitness of this product for every specific experimental setup.

**Technical Support:** The protocols provided are for reference purposes. Unsure if this reagent suits your experiment?

**Need Industrial/Bulk Grade?** [Request Custom Synthesis Quote](#)

## BenchChem

Our mission is to be the trusted global source of essential and advanced chemicals, empowering scientists and researchers to drive progress in science and industry.

### Contact

Address: 3281 E Guasti Rd  
Ontario, CA 91761, United States  
Phone: (601) 213-4426  
Email: [info@benchchem.com](mailto:info@benchchem.com)

Contact our Ph.D. Support Team for a compatibility check