

Physalin F: A Secosteroid's Multifaceted Role in Cellular Processes

Author: BenchChem Technical Support Team. **Date:** April 2026

Compound of Interest

Compound Name: *Physalin F*

Cat. No.: *B10825217*

[Get Quote](#)

A Technical Guide for Researchers and Drug Development Professionals

Introduction

Physalin F, a naturally occurring secosteroid isolated from plants of the *Physalis* genus, has garnered significant attention within the scientific community for its potent biological activities. [1][2] Classified as a withanolide, its unique 16,24-cyclo-13,14-seco-steroid structure contributes to a diverse range of cellular effects, positioning it as a promising candidate for therapeutic development. This technical guide provides an in-depth overview of **physalin F**'s role in key cellular processes, focusing on its anti-cancer and immunomodulatory properties. We will delve into the molecular mechanisms, summarize quantitative data, detail experimental protocols, and visualize the intricate signaling pathways influenced by this compelling natural compound.

Anti-Cancer Activity of Physalin F

Physalin F exhibits significant cytotoxic effects across a broad spectrum of cancer cell lines. Its anti-neoplastic activity is primarily attributed to the induction of apoptosis, cell cycle arrest, and the modulation of critical signaling pathways that govern cell proliferation and survival.

Cytotoxicity and Apoptosis Induction

Physalin F has been shown to inhibit the viability of numerous cancer cell lines in a dose-dependent manner. The half-maximal inhibitory concentration (IC₅₀) values highlight its potent cytotoxic nature.

Table 1: IC₅₀ Values of **Physalin F** in Various Cancer Cell Lines

Cell Line	Cancer Type	IC50 (μM)	Reference
CORL23	Large Cell Lung Carcinoma	0.4 - 1.92	[3]
MCF-7	Breast Cancer	0.4 - 1.92	[3]
22Rv1	Prostate Cancer	< 2.0	[3]
796-O	Kidney Cancer	< 2.0	[3]
A-498	Kidney Cancer	< 2.0	[3]
ACHN	Kidney Cancer	< 2.0	[3]
CEM	Leukemia	< 2.0	[3]
C4-2B	Prostate Cancer	< 2.0	[3]
HT1080	Fibrosarcoma	2.41	[4]
HeLa	Cervical Cancer	< 2.0	[3]
HCT-116	Colorectal Cancer	< 2.0	[3]
HL-60	Promyelocytic Leukemia	< 2.0	[3]
HuCCA-1	Cholangiocarcinoma	< 2.0	[3]
MOLT-3	T-lymphoblastic Leukemia	< 2.0	[3]
H460	Non-small Cell Lung Cancer	1.30	[5]
H1975	Non-small Cell Lung Cancer	0.83	[5]
H1650	Non-small Cell Lung Cancer	1.56	[5]
PBMC (HTLV-1 infected)	Peripheral Blood Mononuclear Cells	0.97 ± 0.11	[6]

The primary mechanism underlying the cytotoxicity of **physalin F** is the induction of apoptosis. This programmed cell death is initiated through both intrinsic and extrinsic pathways.[7] In human renal carcinoma cells, **physalin F** has been shown to induce apoptosis by generating reactive oxygen species (ROS).[8] This leads to the disruption of the mitochondrial membrane potential, release of cytochrome c, and subsequent activation of caspase-9 and caspase-3, ultimately resulting in the cleavage of poly(ADP-ribose) polymerase (PARP).[8] Furthermore, in breast cancer cells, **physalin F** triggers apoptosis through the activation of caspase-3 and c-myc pathways.[9]

Cell Cycle Arrest

In addition to inducing apoptosis, **physalin F** can halt the progression of the cell cycle, thereby inhibiting cancer cell proliferation. Studies have demonstrated that **physalin F** can cause G2/M phase cell cycle arrest in non-small cell lung cancer and renal carcinoma cells.[3][7] This is often associated with an increase in the expression of p53 and the cyclin-dependent kinase inhibitor p21.[3][9]

Immunomodulatory and Anti-inflammatory Effects

Physalin F possesses potent anti-inflammatory and immunomodulatory properties.[2] It has been shown to inhibit the proliferation of lymphocytes and reduce the production of various cytokines.[10]

Inhibition of Inflammatory Mediators

Physalin F can suppress the activation of nuclear factor-kappa B (NF- κ B), a key transcription factor that regulates the expression of pro-inflammatory genes.[8] By inhibiting NF- κ B, **physalin F** reduces the production of inflammatory mediators such as nitric oxide (NO), prostaglandin E2 (PGE2), and pro-inflammatory cytokines like TNF- α , IL-1 β , IL-6, and IL-12.[1] Interestingly, it has also been reported to increase the production of the anti-inflammatory cytokine IL-10.[1] In RAW 264.7 macrophages, **physalin F** has been observed to down-regulate the expression of inducible nitric oxide synthase (iNOS) and cyclooxygenase-2 (COX-2).[5]

Immunosuppressive Activity

The immunosuppressive effects of **physalin F** are highlighted by its ability to inhibit lymphocyte proliferation in a concentration-dependent manner.[10] It also reduces the secretion of key cytokines involved in T-cell responses, including IL-2, IL-4, IL-10, and IFN- γ .[10] Furthermore, **physalin F** has demonstrated the ability to reduce calcineurin activity, a critical enzyme in T-cell activation.[10] In peripheral blood mononuclear cells (PBMCs) from patients with HTLV-1-associated myelopathy, **physalin F** induces apoptosis, leading to a decrease in spontaneous proliferation and cytokine production.[6]

Key Signaling Pathways Modulated by Physalin F

The diverse biological activities of **physalin F** are a consequence of its ability to modulate multiple intracellular signaling pathways.

PI3K/AKT and RAS/MAPK Signaling Pathways

In non-small cell lung cancer cells, **physalin F** has been shown to suppress cell growth by down-regulating the PI3K/AKT and RAS/MAPK signaling pathways.[7] It achieves this by decreasing the phosphorylation levels of both AKT and ERK.[11]

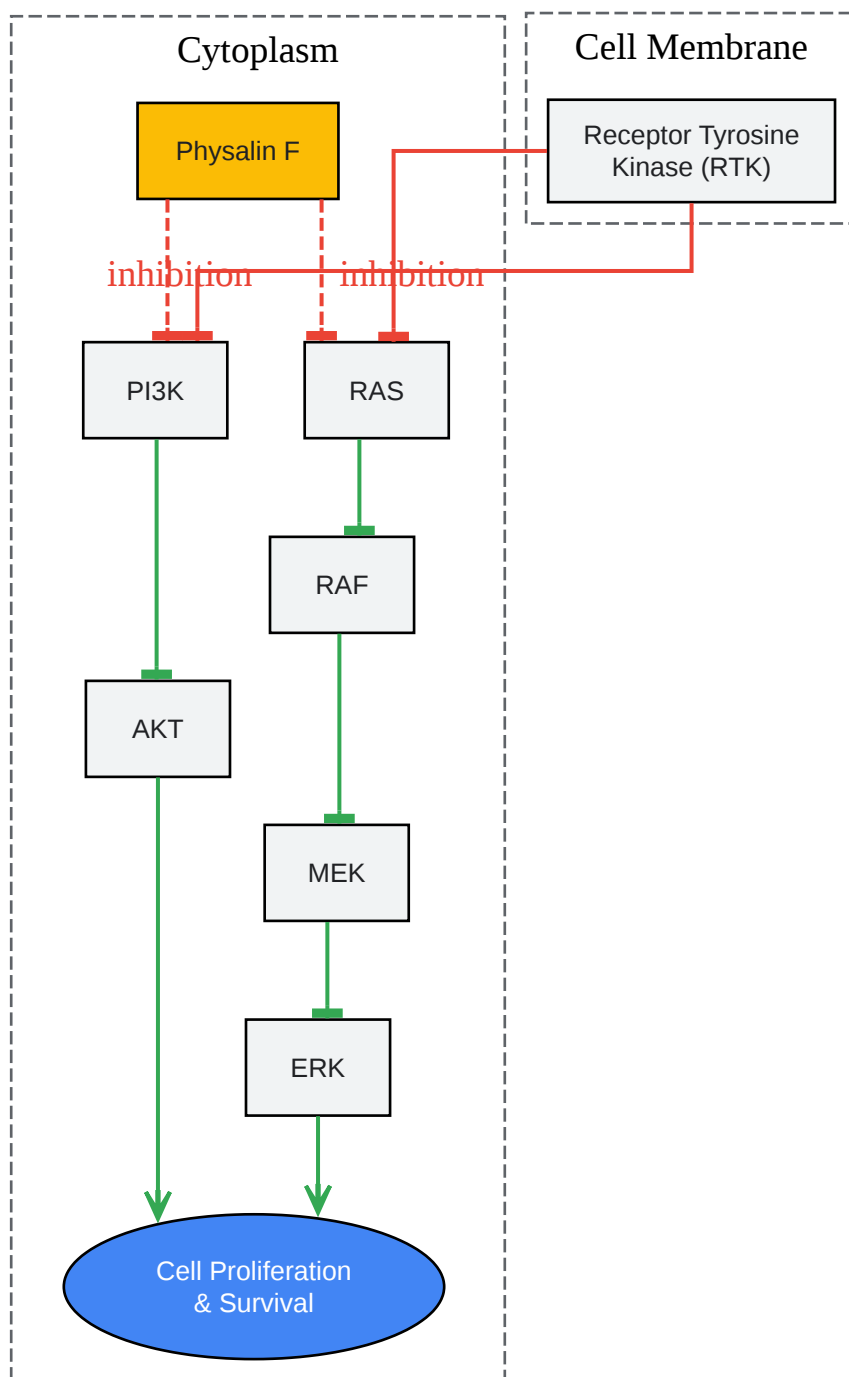

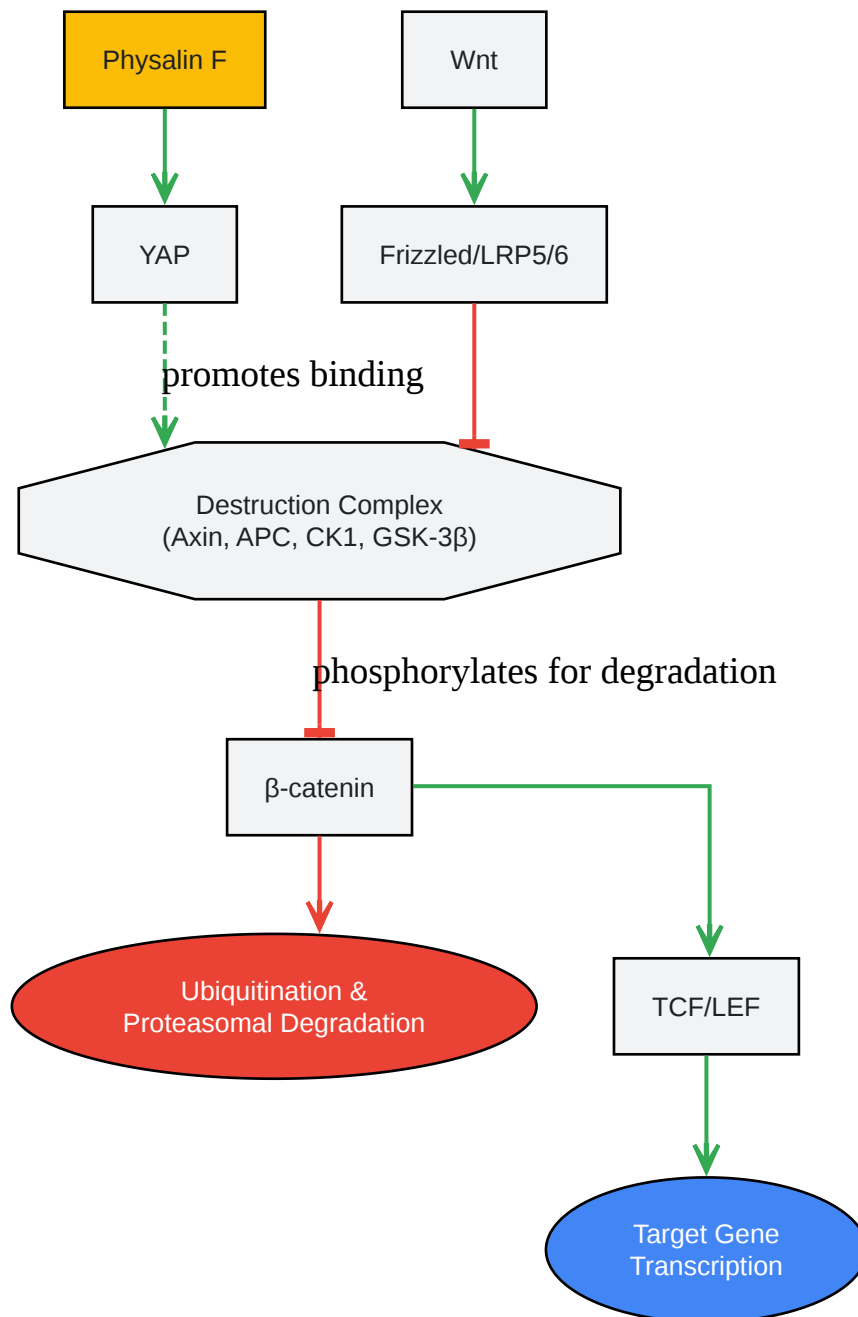

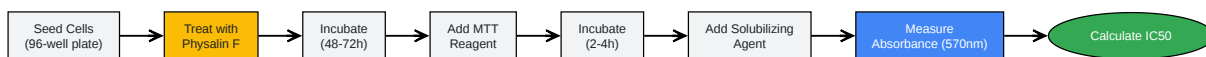
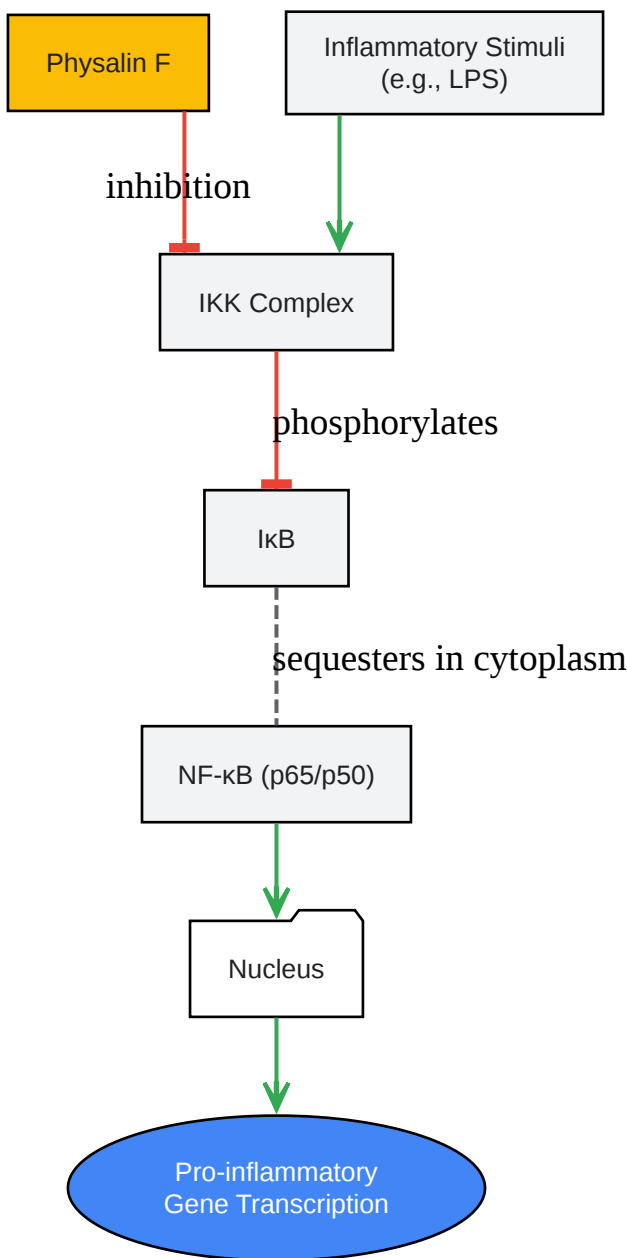

[Click to download full resolution via product page](#)

Need Custom Synthesis?

BenchChem offers custom synthesis for rare earth carbides and specific isotopic labeling.

Email: info@benchchem.com or [Request Quote Online](#).

References

- [1. researchgate.net \[researchgate.net\]](#)
- [2. benchchem.com \[benchchem.com\]](#)
- [3. Frontiers | Therapeutic Applications of Physalins: Powerful Natural Weapons \[frontiersin.org\]](#)
- [4. medchemexpress.com \[medchemexpress.com\]](#)
- [5. researchgate.net \[researchgate.net\]](#)
- [6. Physalin F, a seco-steroid from Physalis angulata L., has immunosuppressive activity in peripheral blood mononuclear cells from patients with HTLV1-associated myelopathy - PubMed \[pubmed.ncbi.nlm.nih.gov\]](#)
- [7. Physalin F Inhibits Cell Viability and Induces Apoptosis in Non-small Cell Lung Cancer Cells - PubMed \[pubmed.ncbi.nlm.nih.gov\]](#)
- [8. Physalin F induces cell apoptosis in human renal carcinoma cells by targeting NF-kappaB and generating reactive oxygen species - PubMed \[pubmed.ncbi.nlm.nih.gov\]](#)
- [9. researchgate.net \[researchgate.net\]](#)
- [10. mdpi.com \[mdpi.com\]](#)
- [11. researchgate.net \[researchgate.net\]](#)
- To cite this document: BenchChem. [Physalin F: A Secosteroid's Multifaceted Role in Cellular Processes]. BenchChem, [2026]. [Online PDF]. Available at: [\[https://www.benchchem.com/product/b10825217/docs#physalin-f-a-secosteroid-s-multifaceted-role-in-cellular-processes\]](https://www.benchchem.com/product/b10825217/docs#physalin-f-a-secosteroid-s-multifaceted-role-in-cellular-processes)

Disclaimer & Data Validity:

The information provided in this document is for Research Use Only (RUO) and is strictly not intended for diagnostic or therapeutic procedures. While BenchChem strives to provide accurate protocols, we make no warranties, express or implied, regarding the fitness of this product for every specific experimental setup.

Technical Support: The protocols provided are for reference purposes. Unsure if this reagent suits your experiment?

Need Industrial/Bulk Grade? [Request Custom Synthesis Quote](#)

BenchChem

Our mission is to be the trusted global source of essential and advanced chemicals, empowering scientists and researchers to drive progress in science and industry.

Contact

Address: 3281 E Guasti Rd
Ontario, CA 91761, United States
Phone: (601) 213-4426
Email: info@benchchem.com

[Contact our Ph.D. Support Team for a compatibility check](#)