

Cmd178 Performance in Different Circuit Topologies: A Comparative Guide

Author: BenchChem Technical Support Team. **Date:** April 2026

Compound of Interest

Compound Name: Cmd178 tfa

Cat. No.: B10825517

[Get Quote](#)

For researchers, scientists, and drug development professionals seeking to understand the performance of the Cmd178 double-balanced mixer in various circuit configurations, this guide provides a comprehensive comparison with alternative components. The following sections detail the Cmd178's performance metrics, its application in more complex topologies, and how it measures up against other high-frequency mixers, supported by experimental data and protocols.

The Cmd178 is a passive double-balanced mixer die designed for up- and down-conversion applications in the 11 to 21 GHz frequency range. Its key features include low conversion loss, high isolation between ports, and a wide IF bandwidth, making it suitable for demanding applications such as electronic warfare, Ku-band radar, and satellite communications.[1]

Performance as a Standard Double-Balanced Mixer

In its fundamental configuration as a double-balanced mixer, the Cmd178 exhibits the following typical performance characteristics.

Parameter	Typical Performance
RF/LO Frequency Range	11 - 21 GHz
IF Frequency Range	DC - 6 GHz
Conversion Loss	6 dB
LO to RF Isolation	45 dB
LO to IF Isolation	45 dB
Input IP3	+16 dBm
LO Drive Level	+9 to +13 dBm

Table 1: Typical performance specifications of the Cmd178 as a standard double-balanced mixer. Data sourced from the Cmd178 datasheet.

Performance in Alternative Circuit Topologies

The Cmd178's versatility allows for its use in more advanced circuit topologies, such as image reject mixers and single sideband modulators, through the use of external hybrids and power splitters.[1]

Image Reject Mixer (IRM)

An image reject mixer is crucial in superheterodyne receivers to suppress the unwanted image frequency, which can interfere with the desired signal. By combining two double-balanced mixers (like the Cmd178), two 90° quadrature hybrids, and an in-phase power divider, an IRM can be constructed. The level of image rejection is highly dependent on the amplitude and phase balance between the two mixer paths.[2][3] A well-designed IRM using components with good matching can achieve image rejection of 20 dB or more.[3]

Single Sideband (SSB) Modulator

In transmitter applications, a single sideband modulator is often used to conserve bandwidth and power by suppressing the carrier and one of the sidebands. Similar to an IRM, an SSB modulator can be built using two double-balanced mixers, quadrature hybrids, and a power combiner. The performance of an SSB modulator is primarily characterized by its sideband

suppression, which is also heavily reliant on the amplitude and phase matching of the components.

While specific performance data for the Cmd178 in these configurations is not readily available in a standard datasheet, the inherent high isolation and good matching of the Cmd178 die make it a suitable candidate for these applications. The overall performance will be dictated by the quality of the external components and the layout of the circuit.

Comparison with Alternative Mixers

For a comprehensive evaluation, the Cmd178 is compared against other high-frequency double-balanced mixers from leading manufacturers, Marki Microwave and Analog Devices.

Parameter	Qorvo Cmd178	Marki Microwave MM1-1044L	Analog Devices HMC557A	Analog Devices ADL5801 (Active Mixer)
RF/LO Frequency Range	11 - 21 GHz	10 - 44 GHz	2.5 - 7.0 GHz	0.01 - 6 GHz
IF Frequency Range	DC - 6 GHz	DC - 14 GHz	DC - 3 GHz	DC - 3 GHz
Conversion Loss/Gain	6 dB (Loss)	7.6 - 14.5 dB (Loss)[4]	8 dB (Loss)[1][5]	1.8 dB (Gain)[6]
LO to RF Isolation	45 dB	47 dB[4]	50 dB[1][5]	>40 dBm
Input IP3	+16 dBm	12.5 - 13.7 dBm[4]	18 dBm[1][5]	28.5 dBm[6]
LO Drive Level	+9 to +13 dBm	+7 to +15 dBm[4]	+15 dBm[1]	0 dBm[6]

Table 2: Performance comparison of the Cmd178 with alternative high-frequency mixers. Note that the ADL5801 is an active mixer and thus has conversion gain.

The Marki Microwave MM1-1044L offers a significantly broader frequency range. The Analog Devices HMC557A operates at a lower frequency band but provides excellent isolation. The Analog Devices ADL5801, being an active mixer, offers the distinct advantage of conversion gain and a very high input IP3, at the cost of higher power consumption.[6]

Experimental Protocols

Accurate characterization of mixer performance is critical for successful system design. The following outlines the general experimental methodologies for measuring key mixer parameters.

Conversion Loss Measurement

Conversion loss is the ratio of the RF input power to the IF output power.

- **Experimental Setup:** A Vector Network Analyzer (VNA) with frequency offset mode or a signal generator and a spectrum analyzer can be used.
- **Procedure:**
 - Apply a known RF signal at a specific frequency and power level to the RF port of the mixer.
 - Apply the specified LO signal to the LO port.
 - Measure the power of the resulting IF signal at the IF port using the spectrum analyzer or VNA.
 - The conversion loss in dB is the difference between the RF input power and the IF output power.

Isolation Measurement

Isolation measures the leakage of a signal from one port to another.

- **Experimental Setup:** A VNA or a signal generator and spectrum analyzer.
- **Procedure (for LO-RF isolation):**

- Apply the LO signal to the LO port.
- Terminate the IF port with a 50-ohm load.
- Measure the power of the LO signal that leaks to the RF port.
- The isolation in dB is the difference between the input LO power and the leaked power at the RF port. Similar procedures are followed for LO-IF and RF-IF isolation.

Third-Order Intercept Point (IP3) Measurement

IP3 is a measure of a mixer's linearity.

- Experimental Setup: Two signal generators, a power combiner, the mixer under test, and a spectrum analyzer.
- Procedure:
 - Apply two closely spaced tones of equal power from the signal generators to the RF port of the mixer via the power combiner.
 - Apply the LO signal to the LO port.
 - Observe the fundamental output signals and the third-order intermodulation products on the spectrum analyzer at the IF port.
 - As the input power is increased, the power of the fundamental output increases linearly, while the power of the third-order products increases at three times the rate.
 - The input IP3 is the theoretical point where the extrapolated power of the fundamental and the third-order products are equal.

Visualizing Circuit Topologies and Workflows

To better understand the concepts discussed, the following diagrams illustrate the logical flow of signals in different mixer configurations and the experimental setup for performance characterization.

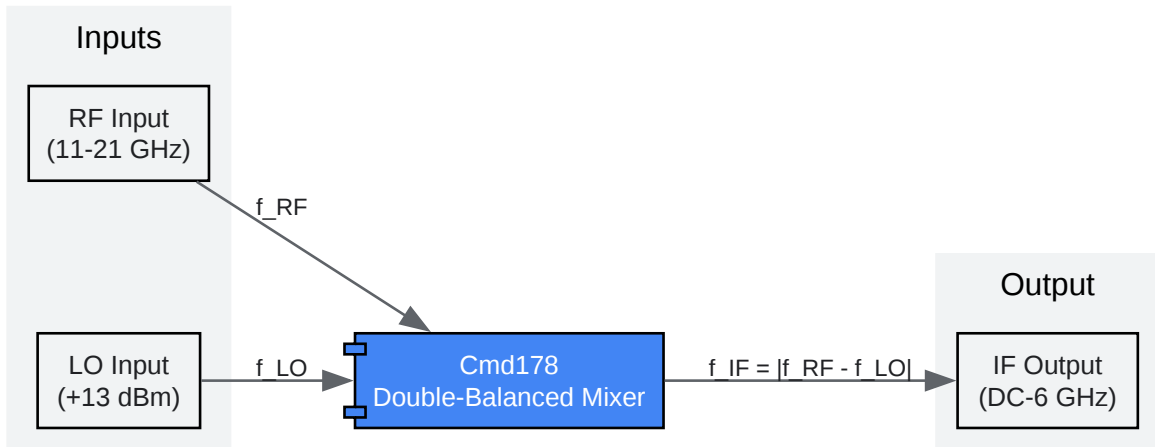

[Click to download full resolution via product page](#)

Signal flow in a standard down-conversion mixer configuration.

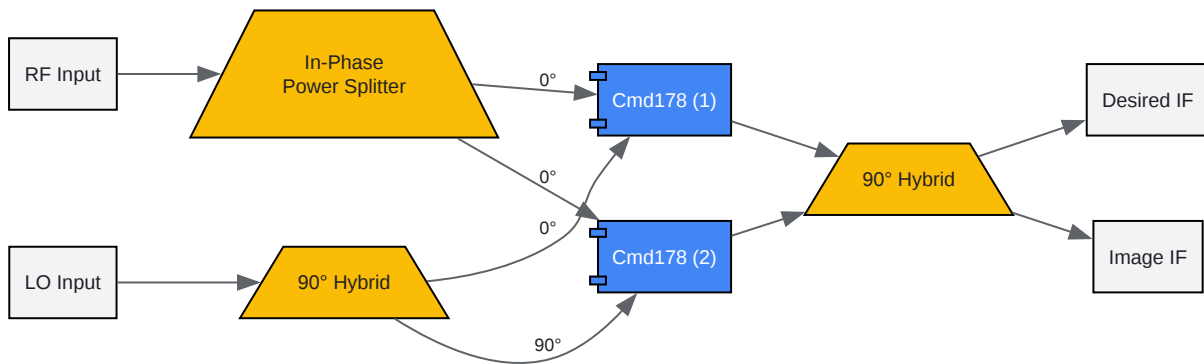

[Click to download full resolution via product page](#)

Block diagram of an Image Reject Mixer (IRM) using two Cmd178 mixers.

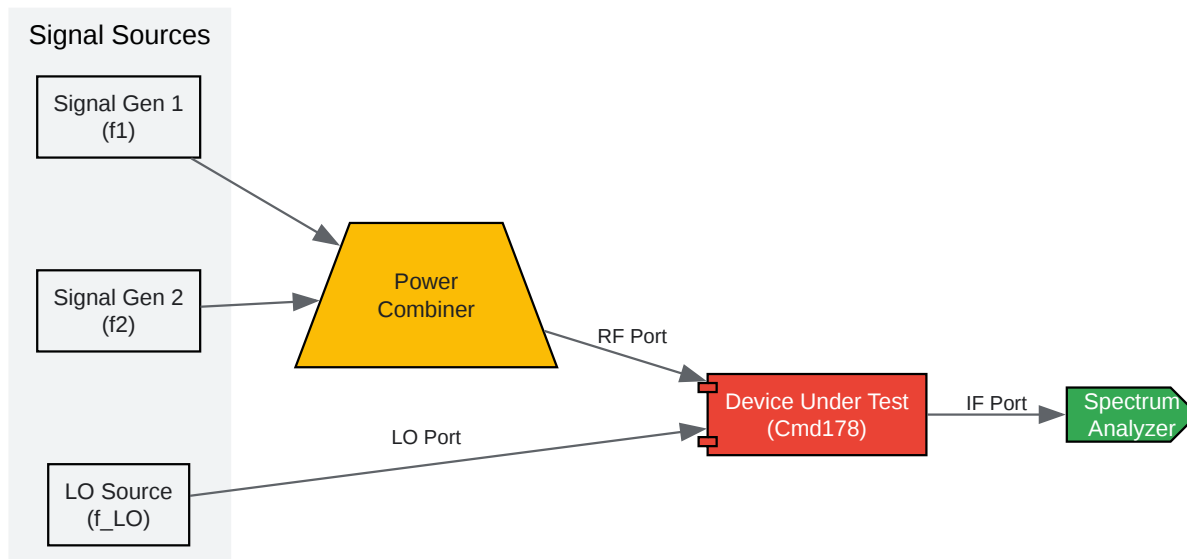

[Click to download full resolution via product page](#)

Experimental workflow for measuring the Third-Order Intercept Point (IP3).

Need Custom Synthesis?

BenchChem offers custom synthesis for rare earth carbides and specific isotopic labeling.

Email: info@benchchem.com or [Request Quote Online](#).

References

- 1. analog.com [analog.com]
- 2. qsl.net [qsl.net]
- 3. rfwireless-world.com [rfwireless-world.com]
- 4. everythingrf.com [everythingrf.com]
- 5. analog.com [analog.com]
- 6. everythingrf.com [everythingrf.com]
- To cite this document: BenchChem. [Cmd178 Performance in Different Circuit Topologies: A Comparative Guide]. BenchChem, [2026]. [Online PDF]. Available at:

[<https://www.benchchem.com/product/b10825517/docs#cmd178-performance-in-different-circuit-topologies-a-comparative-guide>]

Disclaimer & Data Validity:

The information provided in this document is for Research Use Only (RUO) and is strictly not intended for diagnostic or therapeutic procedures. While BenchChem strives to provide accurate protocols, we make no warranties, express or implied, regarding the fitness of this product for every specific experimental setup.

Technical Support: The protocols provided are for reference purposes. Unsure if this reagent suits your experiment?

Need Industrial/Bulk Grade? [Request Custom Synthesis Quote](#)

BenchChem

Our mission is to be the trusted global source of essential and advanced chemicals, empowering scientists and researchers to drive progress in science and industry.

Contact

Address: 3281 E Guasti Rd
Ontario, CA 91761, United States
Phone: (601) 213-4426
Email: info@benchchem.com

[Contact our Ph.D. Support Team for a compatibility check](#)