

optimizing CWP232228 concentration for experiments

Author: BenchChem Technical Support Team. **Date:** April 2026

Compound of Interest

Compound Name: CWP232228

Cat. No.: B10824981

[Get Quote](#)

Technical Support Center: CWP232228

Welcome to the technical support center for **CWP232228**, a selective small-molecule inhibitor of the Wnt/ β -catenin signaling pathway. This guide provides troubleshooting advice and frequently asked questions (FAQs) to assist researchers, scientists, and drug development professionals in optimizing their experiments with **CWP232228**.

Frequently Asked Questions (FAQs)

Q1: What is the mechanism of action of **CWP232228**?

A1: **CWP232228** is a selective inhibitor of the Wnt/ β -catenin signaling pathway. It functions by antagonizing the binding of β -catenin to T-cell factor (TCF) in the nucleus.^{[1][2]} This interaction is crucial for the transcription of target genes involved in cell proliferation, survival, and differentiation. By disrupting this binding, **CWP232228** effectively downregulates the expression of key oncogenes such as c-Myc and cyclin D1.^{[3][4]}

Q2: In which cancer types has **CWP232228** shown efficacy?

A2: **CWP232228** has demonstrated anti-tumor effects in various cancer models, including colorectal cancer, liver cancer, and breast cancer.[3] It has been shown to inhibit tumor growth, induce apoptosis (programmed cell death), and cause cell cycle arrest in cancer cells. Furthermore, it has been observed to preferentially inhibit the growth of cancer stem-like cells.

Q3: What are the typical in vitro effects of **CWP232228** treatment?

A3: In vitro, **CWP232228** treatment typically leads to a dose-dependent cytotoxic effect on cancer cells. This is often accompanied by an induction of apoptosis and arrest of the cell cycle, frequently in the G1 or G2/M phase. Researchers can also expect to see a decrease in the expression of Wnt/ β -catenin target genes.

Troubleshooting Guide

Issue 1: Suboptimal or no cytotoxic effect observed at expected concentrations.

- Possible Cause 1: Cell line resistance. Different cell lines exhibit varying sensitivity to **CWP232228**. The IC50 values can differ significantly between cell types.
 - Solution: Perform a dose-response experiment to determine the optimal concentration for your specific cell line. Start with a broad range of concentrations (e.g., 0.1 μ M to 10 μ M) and narrow down to determine the IC50.
- Possible Cause 2: Incorrect compound handling or storage. **CWP232228**, like many small molecules, may be sensitive to storage conditions.
 - Solution: Ensure the compound is stored as recommended by the manufacturer. Prepare fresh dilutions for each experiment from a stock solution.
- Possible Cause 3: High cell density. A high density of cells can sometimes diminish the apparent effect of a cytotoxic agent.
 - Solution: Optimize cell seeding density to ensure cells are in the logarithmic growth phase during treatment.

Issue 2: High variability between experimental replicates.

- Possible Cause 1: Inconsistent cell seeding. Uneven cell distribution in multi-well plates is a common source of variability.
 - Solution: Ensure thorough mixing of the cell suspension before and during plating. After seeding, gently rock the plate in a cross pattern to ensure even distribution.
- Possible Cause 2: Edge effects in multi-well plates. Wells on the perimeter of a plate are prone to evaporation, which can concentrate the compound and affect cell growth.
 - Solution: Avoid using the outer wells of the plate for experimental conditions. Fill them with sterile PBS or media to maintain humidity.
- Possible Cause 3: Inconsistent treatment duration.
 - Solution: Standardize the incubation time with **CWP232228** across all replicates and experiments.

Data Presentation

Table 1: In Vitro Efficacy of **CWP232228** in Various Cancer Cell Lines

Cell Line	Cancer Type	Parameter	Concentration (μM)	Duration (hours)	Effect
HCT116	Colon Cancer	IC50	4.81	24	Cytotoxicity
HCT116	Colon Cancer	IC50	1.31	48	Cytotoxicity
HCT116	Colon Cancer	IC50	0.91	72	Cytotoxicity
4T1	Breast Cancer	IC50	2	48	Cytotoxicity
MDA-MB-435	Breast Cancer	IC50	0.8	48	Cytotoxicity
Hep3B	Liver Cancer	N/A	Dose-dependent	N/A	Decreased Wnt/β-catenin signaling

Experimental Protocols

1. Cell Viability (Cytotoxicity) Assay

This protocol is based on methodologies described for assessing the cytotoxic effects of **CWP232228**.

- Cell Seeding: Seed cancer cells in a 96-well plate at a predetermined optimal density.
- Incubation: Allow cells to adhere and enter logarithmic growth phase by incubating for 24 hours at 37°C and 5% CO₂.
- Treatment: Prepare serial dilutions of **CWP232228** in complete culture medium. Replace the existing medium with the medium containing the desired concentrations of **CWP232228**. Include a vehicle control (e.g., DMSO) at the same concentration as the highest **CWP232228** concentration.
- Incubation: Incubate the plate for the desired duration (e.g., 24, 48, or 72 hours).
- Viability Assessment: Use a cell viability reagent such as MTS or a cell counting kit-8 (CCK-8) according to the manufacturer's instructions.
- Data Analysis: Measure the absorbance at the appropriate wavelength using a microplate reader. Calculate cell viability as a percentage relative to the vehicle-treated control.

2. Western Blot Analysis for Wnt/ β -catenin Signaling Targets

This protocol is adapted from methods used to assess the impact of **CWP232228** on protein expression.

- Cell Treatment: Seed cells in 6-well plates and treat with **CWP232228** at the desired concentrations for the specified time.
- Cell Lysis: Wash cells with ice-cold PBS and lyse them in RIPA buffer containing protease and phosphatase inhibitors.
- Protein Quantification: Determine the protein concentration of the lysates using a BCA protein assay.

- **SDS-PAGE and Transfer:** Separate equal amounts of protein (e.g., 30 μ g) on an SDS-polyacrylamide gel and transfer the proteins to a PVDF membrane.
- **Blocking:** Block the membrane with 3-5% bovine serum albumin (BSA) in TBST for 1 hour at room temperature.
- **Primary Antibody Incubation:** Incubate the membrane with primary antibodies against β -catenin, c-Myc, Cyclin D1, or other targets overnight at 4°C.
- **Secondary Antibody Incubation:** Wash the membrane and incubate with the appropriate HRP-conjugated secondary antibody for 1 hour at room temperature.
- **Detection:** Visualize the protein bands using a chemiluminescent substrate and an imaging system.

Visualizations

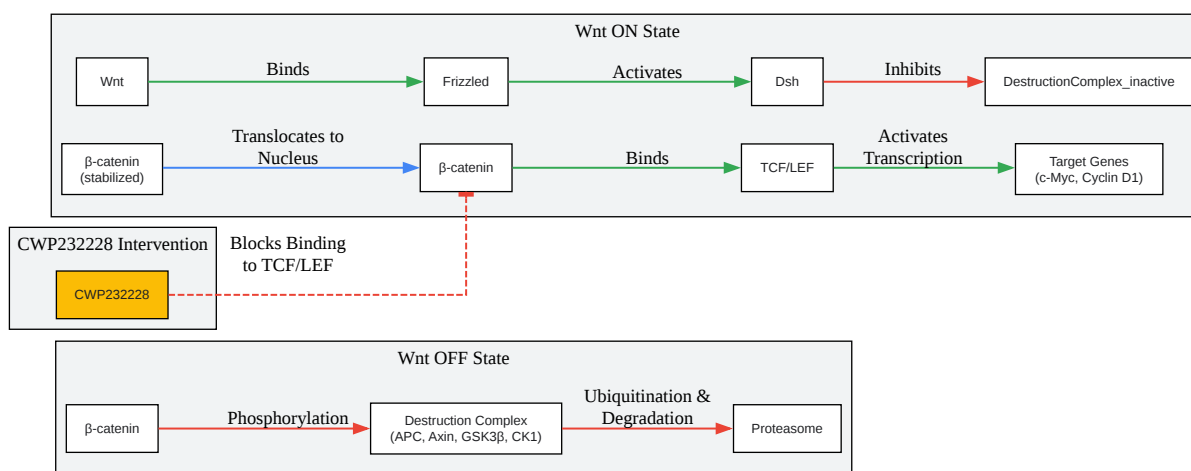

[Click to download full resolution via product page](#)

Caption: Mechanism of action of **CWP232228** in the Wnt/ β -catenin signaling pathway.

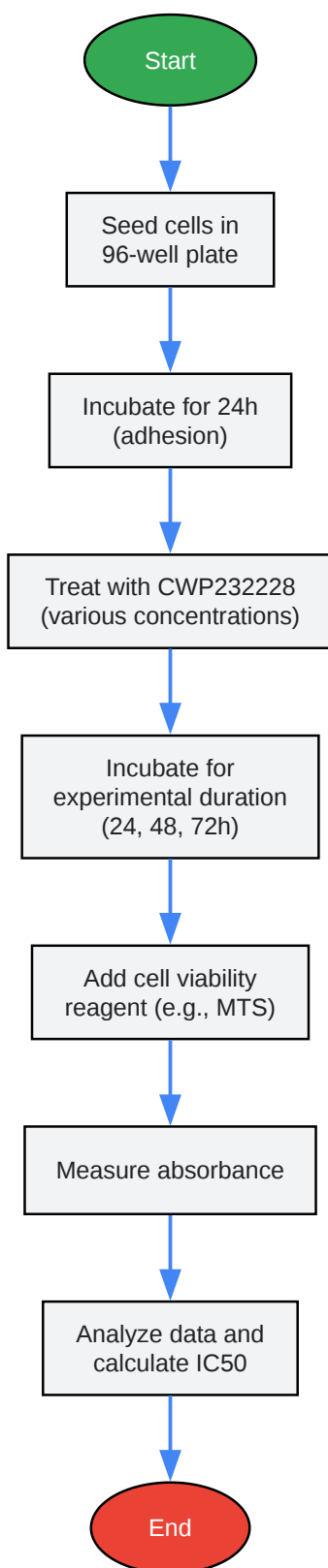

[Click to download full resolution via product page](#)

Caption: Experimental workflow for determining cell viability upon **CWP232228** treatment.

Need Custom Synthesis?

BenchChem offers custom synthesis for rare earth carbides and specific isotopic labeling.

Email: info@benchchem.com or [Request Quote Online](#).

References

- [1. CWP232228 targets liver cancer stem cells through Wnt/ \$\beta\$ -catenin signaling: a novel therapeutic approach for liver cancer treatment - PMC \[pmc.ncbi.nlm.nih.gov\]](#)
- [2. Wnt/ \$\beta\$ -Catenin Small-Molecule Inhibitor CWP232228 Preferentially Inhibits the Growth of Breast Cancer Stem-like Cells - PubMed \[pubmed.ncbi.nlm.nih.gov\]](#)
- [3. ar.iiarjournals.org \[ar.iiarjournals.org\]](#)
- [4. Selective Wnt/ \$\beta\$ -catenin Small-molecule Inhibitor CWP232228 Impairs Tumor Growth of Colon Cancer | Anticancer Research \[ar.iiarjournals.org\]](#)
- To cite this document: BenchChem. [optimizing CWP232228 concentration for experiments]. BenchChem, [2026]. [Online PDF]. Available at: [\[https://www.benchchem.com/product/b10824981/docs#optimizing-cwp232228-concentration-for-experiments\]](https://www.benchchem.com/product/b10824981/docs#optimizing-cwp232228-concentration-for-experiments)

Disclaimer & Data Validity:

The information provided in this document is for Research Use Only (RUO) and is strictly not intended for diagnostic or therapeutic procedures. While BenchChem strives to provide accurate protocols, we make no warranties, express or implied, regarding the fitness of this product for every specific experimental setup.

Technical Support: The protocols provided are for reference purposes. Unsure if this reagent suits your experiment?

Need Industrial/Bulk Grade? [Request Custom Synthesis Quote](#)

BenchChem

Our mission is to be the trusted global source of essential and advanced chemicals, empowering scientists and researchers to drive progress in science and industry.

Contact

Address: 3281 E Guasti Rd

Ontario, CA 91761, United States

Phone: (601) 213-4426

Email: info@benchchem.com

[Contact our Ph.D. Support Team for a compatibility check](#)