

interpreting unexpected results from AI-10-47 experiments

Author: BenchChem Technical Support Team. **Date:** April 2026

Compound of Interest

Compound Name: AI-10-47

Cat. No.: B8143755

[Get Quote](#)

Technical Support Center: AI-10-47 Experiments

This guide provides troubleshooting advice and answers to frequently asked questions for researchers using **AI-10-47**, a small molecule inhibitor of the CBF β -RUNX protein-protein interaction.

Frequently Asked Questions (FAQs)

Q1: What is the mechanism of action for **AI-10-47**?

A1: **AI-10-47** is a small molecule that inhibits the binding of Core-Binding Factor Subunit Beta (CBF β) to Runt-related transcription factor 1 (RUNX1).[1][2] By disrupting this interaction, **AI-10-47** can modulate the transcriptional activity of RUNX1, which is implicated in certain types of cancer.

Q2: What is the recommended solvent and storage condition for **AI-10-47**?

A2: **AI-10-47** is typically soluble in DMSO at high concentrations (e.g., 100 mg/mL).[3] For stock solutions, it is recommended to store them at -80°C for up to 6 months or at -20°C for up to 1 month, protected from light.[1][3]

Q3: What is the reported IC50 for **AI-10-47**?

A3: The reported IC50 for **AI-10-47** in inhibiting the CBF β -RUNX binding is 3.2 μ M.^{[1][2]}

However, the effective concentration in cell-based assays may vary depending on the cell line and experimental conditions.

Troubleshooting Unexpected Results

Issue 1: Lower than Expected Potency in Cell-Based Assays

Question: I am observing a significantly weaker effect of **AI-10-47** on cell viability or target gene expression than anticipated from the published IC50 value. What could be the reason?

Answer: This is a common issue that can arise from several factors, most notably the compound's solubility and stability in aqueous cell culture media. One publication noted that **AI-10-47** weakly reduced CBF β binding to RUNX1 in cells, which may be due to its poor solubility.

^{[1][3]}

Troubleshooting Steps:

- **Verify Stock Solution:** Ensure your stock solution in DMSO is fully dissolved. Gentle warming and vortexing can help.
- **Check Working Concentration:** High concentrations of **AI-10-47** in aqueous media can lead to precipitation. It is advisable to visually inspect the media for any precipitate after adding the compound.
- **Optimize Dilution Series:** When preparing your working dilutions, perform serial dilutions in media and add them to the cells immediately. Avoid storing the compound in aqueous solutions for extended periods.
- **Incorporate a Surfactant:** For in vitro binding assays, a small amount of a non-ionic surfactant like Tween-20 (e.g., 0.01%) in the buffer can help maintain solubility. For cell-based assays, the presence of serum can aid solubility.

- Consider a More Soluble Analog: If solubility issues persist and impact your results, consider using a more potent or soluble analog if available. For instance, AI-10-49 is a bivalent inhibitor derived from a similar chemical scaffold with enhanced activity.[4]

Summary of Potency Observations for AI-10-47

Cell Line	Assay Type	Observed IC50	Potential Cause of Discrepancy
ME-1	Cell Growth	>10 μ M	Poor compound solubility in media
SEM	Co-IP	Weak Inhibition at 10 μ M	Compound precipitation
THP-1	Cell Growth	~5-10 μ M	Sub-optimal dilution protocol

Issue 2: High Variability Between Experimental Replicates

Question: My results with **AI-10-47** are inconsistent across replicate wells or between experiments. Why is this happening?

Answer: High variability is often linked to inconsistent dosing, which can be exacerbated by the compound's solubility challenges. Inaccurate cell seeding and assay timing can also contribute to variability.

Troubleshooting Steps:

- Standardize Compound Addition: Ensure a consistent and thorough mixing of the media after adding **AI-10-47** to each well.
- Cell Density: Maintain a consistent cell density across all wells, as this can significantly influence the drug response.[5]
- Incubation Time: Use a consistent incubation time for all experiments.

- Solubility Check: Before adding to cells, prepare the highest concentration of your dilution series and inspect it under a microscope for signs of precipitation.

Diagrams and Workflows

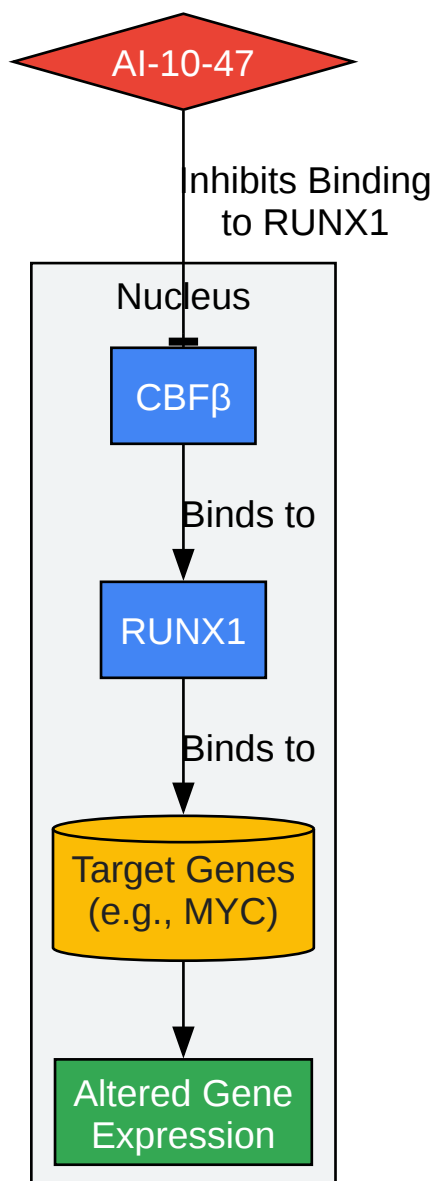

[Click to download full resolution via product page](#)

Caption: Intended signaling pathway and mechanism of action of **AI-10-47**.

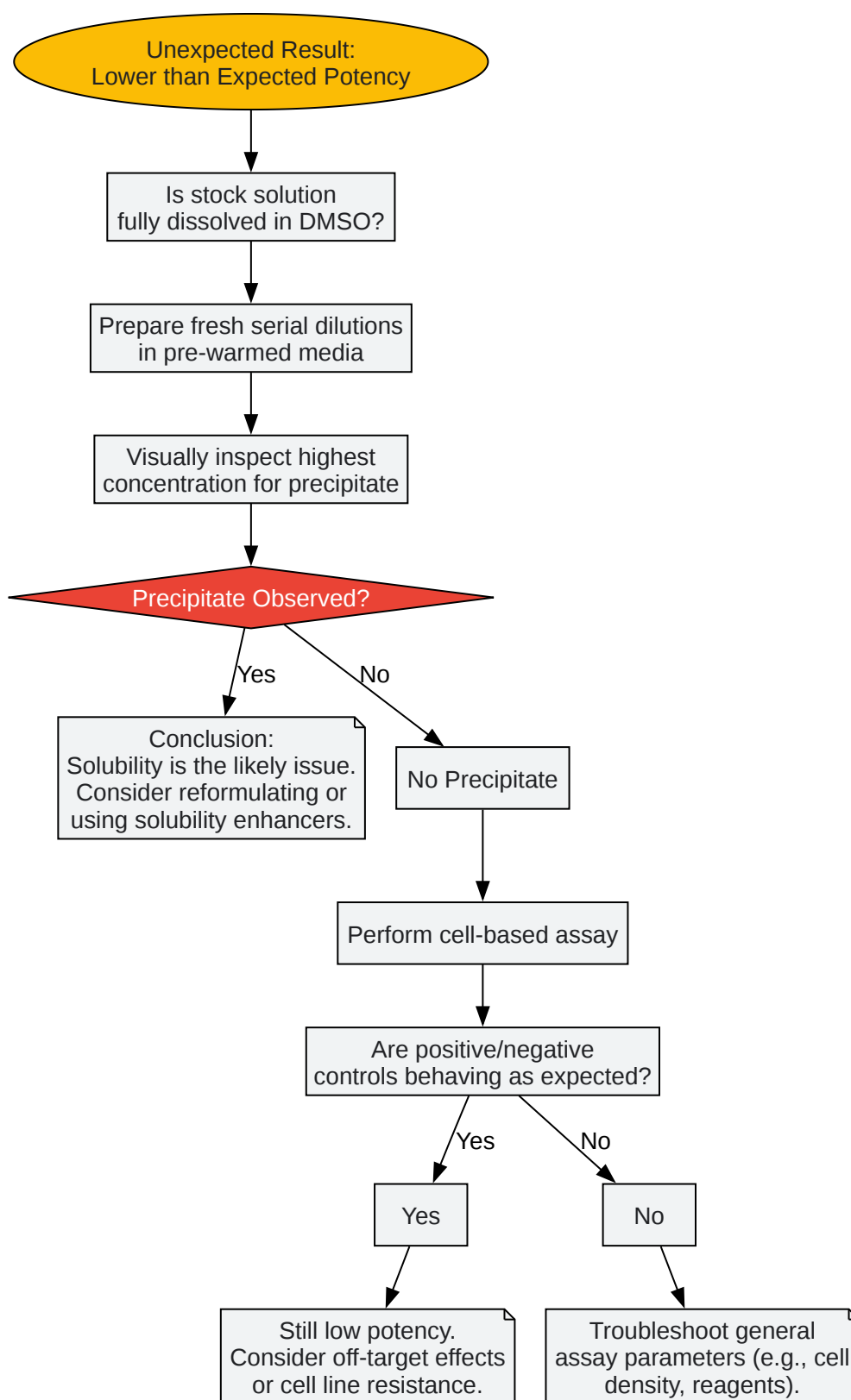

[Click to download full resolution via product page](#)

Caption: Troubleshooting workflow for low potency of **AI-10-47**.

Experimental Protocols

Protocol 1: Preparation of AI-10-47 Stock and Working Solutions

- Stock Solution (10 mM):
 - Allow the vial of **AI-10-47** powder to equilibrate to room temperature before opening.
 - Reconstitute the powder in high-quality, anhydrous DMSO to a final concentration of 10 mM.
 - To ensure complete dissolution, vortex the solution for 1-2 minutes and gently warm to 37°C if necessary.
 - Aliquot the stock solution into smaller volumes to avoid repeated freeze-thaw cycles.
 - Store at -80°C.
- Working Solutions:
 - Thaw an aliquot of the 10 mM stock solution at room temperature.
 - Pre-warm the required volume of cell culture medium to 37°C.
 - Perform serial dilutions of the stock solution directly into the pre-warmed medium to achieve the final desired concentrations.
 - Mix each dilution thoroughly by pipetting up and down before adding to the cell culture plates.
 - Use the working solutions immediately after preparation.

Protocol 2: Western Blot for RUNX1 Target Protein Expression

- Cell Lysis:

- Plate and treat cells with **AI-10-47** or vehicle control (DMSO) for the desired time.
- Wash cells once with ice-cold PBS and lyse with RIPA buffer containing protease and phosphatase inhibitors.
- Scrape the cells and collect the lysate. Centrifuge at 14,000 x g for 15 minutes at 4°C to pellet cell debris.
- Protein Quantification:
 - Determine the protein concentration of the supernatant using a BCA assay.
- SDS-PAGE and Transfer:
 - Normalize protein amounts for all samples and prepare them with Laemmli buffer.
 - Separate proteins on a 4-20% Tris-Glycine gel.
 - Transfer the separated proteins to a PVDF membrane.
- Immunoblotting:
 - Block the membrane with 5% non-fat milk or BSA in TBST for 1 hour at room temperature.
 - Incubate the membrane with a primary antibody against a known RUNX1 target (e.g., MYC) overnight at 4°C.
 - Wash the membrane three times with TBST.
 - Incubate with an appropriate HRP-conjugated secondary antibody for 1 hour at room temperature.
 - Wash the membrane again three times with TBST.
- Detection:
 - Detect the signal using an enhanced chemiluminescence (ECL) substrate and image the blot.

- Normalize the target protein signal to a loading control (e.g., GAPDH or β -actin).

Need Custom Synthesis?

BenchChem offers custom synthesis for rare earth carbides and specific isotopic labeling.

Email: info@benchchem.com or [Request Quote Online](#).

References

- [1. medchemexpress.com](https://www.medchemexpress.com) [[medchemexpress.com](https://www.medchemexpress.com)]
- [2. medchemexpress.com](https://www.medchemexpress.com) [[medchemexpress.com](https://www.medchemexpress.com)]
- [3. file.medchemexpress.com](https://www.file.medchemexpress.com) [[file.medchemexpress.com](https://www.file.medchemexpress.com)]
- [4. A small-molecule inhibitor of the aberrant transcription factor CBF \$\beta\$ -SMMHC delays leukemia in mice - PMC](#) [[pmc.ncbi.nlm.nih.gov](https://pubmed.ncbi.nlm.nih.gov/)]
- [5. researchgate.net](https://www.researchgate.net) [[researchgate.net](https://www.researchgate.net)]
- To cite this document: BenchChem. [interpreting unexpected results from AI-10-47 experiments]. BenchChem, [2026]. [Online PDF]. Available at: [<https://www.benchchem.com/product/b8143755/docs#interpreting-unexpected-results-from-ai-10-47-experiments>]

Disclaimer & Data Validity:

The information provided in this document is for Research Use Only (RUO) and is strictly not intended for diagnostic or therapeutic procedures. While BenchChem strives to provide accurate protocols, we make no warranties, express or implied, regarding the fitness of this product for every specific experimental setup.

Technical Support: The protocols provided are for reference purposes. Unsure if this reagent suits your experiment?

Need Industrial/Bulk Grade? [Request Custom Synthesis Quote](#)

BenchChem

Our mission is to be the trusted global source of essential and advanced chemicals, empowering scientists and researchers to drive progress in science and industry.

Contact

Address: 3281 E Guasti Rd

Ontario, CA 91761, United States

Phone: (601) 213-4426

Email: info@benchchem.com

[Contact our Ph.D. Support Team for a compatibility check](#)