

# Technical Support Center: Limertinib IC50 Determination

**Author:** BenchChem Technical Support Team. **Date:** April 2026

## Compound of Interest

Compound Name: *limertinib*  
CAS No.: *1934259-00-3*  
Cat. No.: *B10824888*

[Get Quote](#)

This technical support center provides troubleshooting guides and frequently asked questions (FAQs) for researchers, scientists, and drug development professionals working with the EGFR inhibitor, **limertinib**. The following information addresses common issues encountered during in vitro experiments, with a specific focus on the impact of cell confluence on IC50 value determination.

## Frequently Asked Questions (FAQs)

Q1: We are observing significant variability in our **limertinib** IC50 values between experiments. What are the potential causes?

A1: Variability in IC50 values for **limertinib** can stem from several factors. One of the most common is inconsistent cell confluence at the time of drug treatment.<sup>[1][2]</sup> The density of the cell culture can significantly influence the drug's efficacy.<sup>[3]</sup> Other contributing factors include:

- Cell Health and Passage Number: Using cells that are unhealthy, in a high passage number, or not in the logarithmic growth phase can lead to inconsistent results.<sup>[4][5]</sup>

- **Inconsistent Seeding Density:** Variations in the initial number of cells seeded per well will result in different cell densities at the time of assay, affecting the IC50 value.[6][7]
- **Reagent Preparation and Handling:** Errors in serial dilutions of **limertinib**, improper storage, or variations in media and supplements can introduce variability.[4]
- **Assay Endpoint and Duration:** The incubation time with the drug can significantly alter the apparent IC50. Ensure this is kept consistent across all experiments.[1]

Q2: How does cell confluence specifically affect the IC50 of an EGFR inhibitor like **limertinib**?

A2: Cell confluence, or the percentage of the culture surface covered by cells, can directly impact the determined IC50 value. Higher cell densities can lead to a phenomenon known as density-dependent chemoresistance.[3] This can result in an artificially inflated IC50 value, making the drug appear less potent. The mechanisms behind this can include:

- **Altered Cell Proliferation Rates:** As cells become more confluent, their proliferation rate can slow down, which may affect the efficacy of drugs that target rapidly dividing cells.[8]
- **Increased Cell-Cell Contact:** Increased contact between cells can trigger signaling pathways that promote survival and resistance to apoptosis.[2]
- **Changes in Drug Availability:** At higher cell densities, the effective concentration of the drug per cell may be reduced.

Q3: What is the recommended cell confluence for an IC50 assay with **limertinib**?

A3: There is no single universal confluence that is optimal for all cell lines. The ideal confluence should be determined empirically for each cell line used. As a general guideline, cells should be in their exponential or logarithmic growth phase and not be overly confluent.[9] A starting point for optimization is to ensure the cells are around 70-80% confluent at the end of the drug treatment period in the vehicle-treated control wells.[7] It is crucial to perform a cell seeding density optimization experiment to determine the optimal conditions for your specific assay.

## Troubleshooting Guides

### Issue: Inconsistent IC50 Values

Potential Cause	Troubleshooting Step
Variable Cell Confluence	Standardize the cell seeding density. Perform a cell density optimization experiment to find the optimal seeding number for your cell line and assay duration. Ensure cells are in the logarithmic growth phase when treated.[6][9]
Inconsistent Cell Health	Use cells within a consistent and low passage number range.[5] Regularly check cell viability before seeding using a method like trypan blue exclusion.[6]
Pipetting Errors	Calibrate pipettes regularly. Use a multichannel pipette for seeding and ensure even cell distribution by letting the plate sit at room temperature on a level surface for 15-20 minutes before incubation.[6]
Reagent Variability	Prepare fresh serial dilutions of limertinib for each experiment. Use consistent lots of media, serum, and other supplements.[4]

## Issue: Higher than Expected IC50 Values

Potential Cause	Troubleshooting Step
High Cell Seeding Density	Reduce the initial cell seeding density. Overly confluent cells can exhibit increased resistance to the drug.[3]
Incorrect Assay Duration	Optimize the drug incubation time. A shorter or longer exposure could affect the apparent IC50.
Compound Solubility Issues	Ensure limertinib is fully dissolved in the stock solution (typically DMSO) and diluted appropriately in the final assay medium to avoid precipitation.

## Quantitative Data

The following table illustrates the potential impact of cell seeding density on the IC<sub>50</sub> of a hypothetical EGFR inhibitor, based on general trends observed in the literature.[3][10] It is crucial to generate similar data for your specific cell line and experimental conditions.

Seeding Density (cells/well)	Cell Confluence at Assay Endpoint (Vehicle Control)	Apparent IC <sub>50</sub> (nM)
2,000	~50%	8.5
5,000	~80%	15.2
10,000	>95% (Overconfluent)	35.8

## Experimental Protocols

### Protocol: Optimizing Cell Seeding Density for Limertinib IC<sub>50</sub> Assay

This protocol outlines the steps to determine the optimal cell seeding density for a **limertinib** IC<sub>50</sub> assay.

- Cell Preparation:
  - Culture the desired cancer cell line (e.g., a non-small cell lung cancer line with an EGFR mutation) in the recommended growth medium.
  - Ensure the cells are healthy, in a logarithmic growth phase, and at a low passage number.
  - Harvest the cells using standard trypsinization methods and perform a cell count to determine the cell concentration and viability.
- Cell Seeding:
  - Prepare a serial dilution of the cell suspension to achieve a range of seeding densities (e.g., 1,000, 2,500, 5,000, 7,500, and 10,000 cells per well) in a 96-well plate.

- Seed the cells in triplicate for each density.
- Include wells with media only as a background control.
- Incubate the plate for the intended duration of the **limertinib** treatment (e.g., 72 hours).
- Cell Viability Assay:
  - At the end of the incubation period, perform a cell viability assay (e.g., MTT, MTS, or CellTiter-Glo®).
  - Measure the absorbance or luminescence according to the assay manufacturer's instructions.
- Data Analysis:
  - Subtract the background reading from all wells.
  - Plot the viability signal (e.g., absorbance) against the number of cells seeded.
  - Identify the linear range of the curve. The optimal seeding density will be within this linear range, where the signal is proportional to the cell number and the cells in the highest density wells are not overconfluent.

## Protocol: Limertinib IC50 Determination

- Cell Seeding:
  - Based on the optimization experiment, seed the cells at the determined optimal density in a 96-well plate.
  - Incubate the plate overnight to allow for cell attachment.
- **Limertinib** Treatment:
  - Prepare a serial dilution of **limertinib** in the appropriate culture medium. The concentration range should span several orders of magnitude around the expected IC50.

- Include a vehicle control (e.g., DMSO at the same final concentration as in the drug-treated wells).
- Remove the old medium from the cells and add the medium containing the different concentrations of **limertinib**.
- Incubate for the desired treatment duration (e.g., 72 hours).
- Cell Viability Assay:
  - Perform a cell viability assay as described in the optimization protocol.
- IC50 Calculation:
  - Normalize the data by setting the vehicle control as 100% viability and a no-cell control as 0% viability.[\[11\]](#)
  - Plot the percentage of cell viability against the logarithm of the **limertinib** concentration.
  - Fit the data to a sigmoidal dose-response curve using a non-linear regression analysis to determine the IC50 value (the concentration of **limertinib** that inhibits cell growth by 50%).  
[\[12\]](#)[\[13\]](#)

## Visualizations

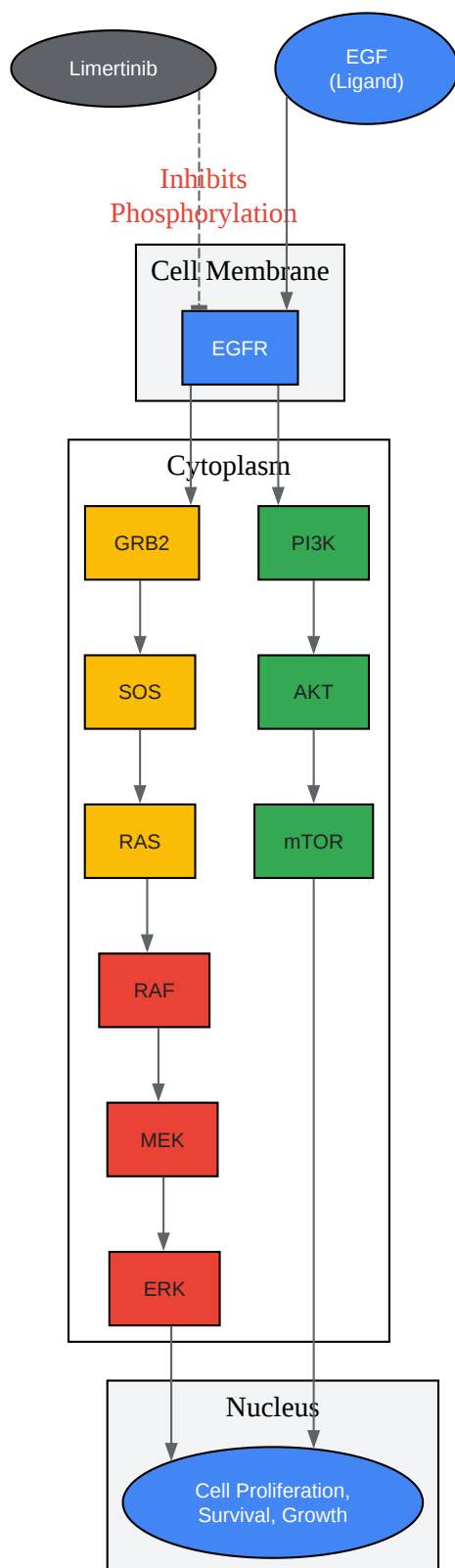

[Click to download full resolution via product page](#)

Caption: Simplified EGFR signaling pathway and the inhibitory action of **limertinib**.

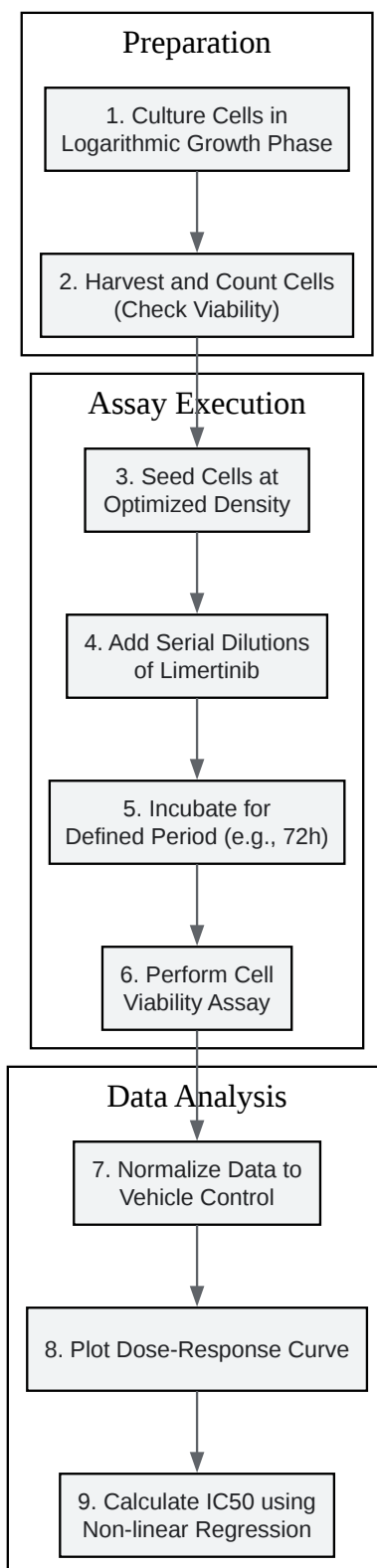

[Click to download full resolution via product page](#)

Caption: Experimental workflow for determining the IC<sub>50</sub> of **limertinib**.

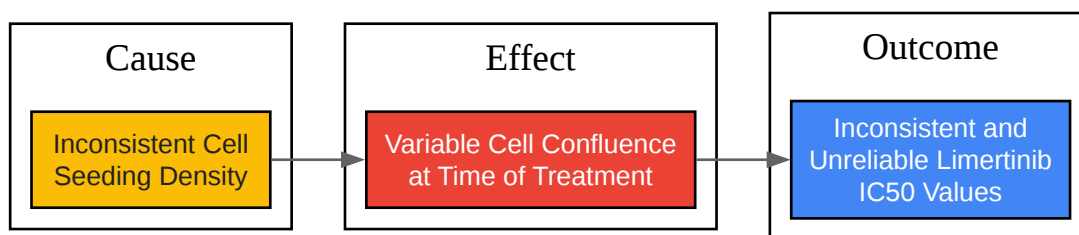

[Click to download full resolution via product page](#)

Caption: Relationship between cell seeding density, confluence, and IC50 variability.

### ***Need Custom Synthesis?***

*BenchChem offers custom synthesis for rare earth carbides and specific isotopic labeling.*

*Email: [info@benchchem.com](mailto:info@benchchem.com) or [Request Quote Online](#).*

## References

- [1. benchchem.com](https://www.benchchem.com) [benchchem.com]
- [2. thrivebio.com](https://www.thrivebio.com) [thrivebio.com]
- [3. Cancer cell seeding density as a mechanism of chemotherapy resistance: a novel cancer cell density index based on IC50-Seeding Density Slope \(ISDS\) to assess chemosensitivity - PMC](#) [pmc.ncbi.nlm.nih.gov]
- [4. biocompare.com](https://www.biocompare.com) [biocompare.com]
- [5. researchgate.net](https://www.researchgate.net) [researchgate.net]
- [6. benchchem.com](https://www.benchchem.com) [benchchem.com]
- [7. researchgate.net](https://www.researchgate.net) [researchgate.net]
- [8. researchgate.net](https://www.researchgate.net) [researchgate.net]
- [9. youtube.com](https://www.youtube.com) [youtube.com]
- [10. researchgate.net](https://www.researchgate.net) [researchgate.net]
- [11. clyte.tech](https://www.clyte.tech) [clyte.tech]
- [12. researchgate.net](https://www.researchgate.net) [researchgate.net]
- [13. researchgate.net](https://www.researchgate.net) [researchgate.net]

- To cite this document: BenchChem. [Technical Support Center: Limertinib IC50 Determination]. BenchChem, [2026]. [Online PDF]. Available at: [<https://www.benchchem.com/product/b10824888/docs#technical-support-center-limertinib-ic50-determination>]

---

### Disclaimer & Data Validity:

The information provided in this document is for Research Use Only (RUO) and is strictly not intended for diagnostic or therapeutic procedures. While BenchChem strives to provide accurate protocols, we make no warranties, express or implied, regarding the fitness of this product for every specific experimental setup.

**Technical Support:** The protocols provided are for reference purposes. Unsure if this reagent suits your experiment?

**Need Industrial/Bulk Grade?** [Request Custom Synthesis Quote](#)

## BenchChem

Our mission is to be the trusted global source of essential and advanced chemicals, empowering scientists and researchers to drive progress in science and industry.

### Contact

Address: 3281 E Guasti Rd  
Ontario, CA 91761, United States  
Phone: (601) 213-4426  
Email: [info@benchchem.com](mailto:info@benchchem.com)

[Contact our Ph.D. Support Team for a compatibility check](#)