

SRI-29329 In Vitro Assay: Application Notes and Protocols for Researchers

Author: BenchChem Technical Support Team. **Date:** April 2026

Compound of Interest

Compound Name: SRI-29329

Cat. No.: B10824542

[Get Quote](#)

For researchers, scientists, and drug development professionals, this document provides detailed application notes and protocols for the in vitro assessment of **SRI-29329**, a potent inhibitor of Cdc2-like kinases (CLKs).

SRI-29329 is a specific inhibitor of CLK1, CLK2, and CLK4, dual-specificity kinases that play a critical role in the regulation of pre-mRNA splicing through the phosphorylation of serine/arginine-rich (SR) proteins. Dysregulation of CLK activity has been implicated in various diseases, making it a compelling target for therapeutic intervention. These notes offer a guide to understanding and quantifying the inhibitory action of **SRI-29329** in biochemical and cellular assays.

Quantitative Data Summary

The inhibitory activity of **SRI-29329** against its primary kinase targets has been determined through in vitro kinase assays. The half-maximal inhibitory concentration (IC₅₀) values are summarized in the table below for easy comparison.

Target Kinase	IC50 (nM)
CLK1	78
CLK2	16
CLK4	86

Signaling Pathway and Experimental Workflow

The following diagrams illustrate the signaling pathway affected by **SRI-29329** and a general workflow for assessing its in vitro activity.

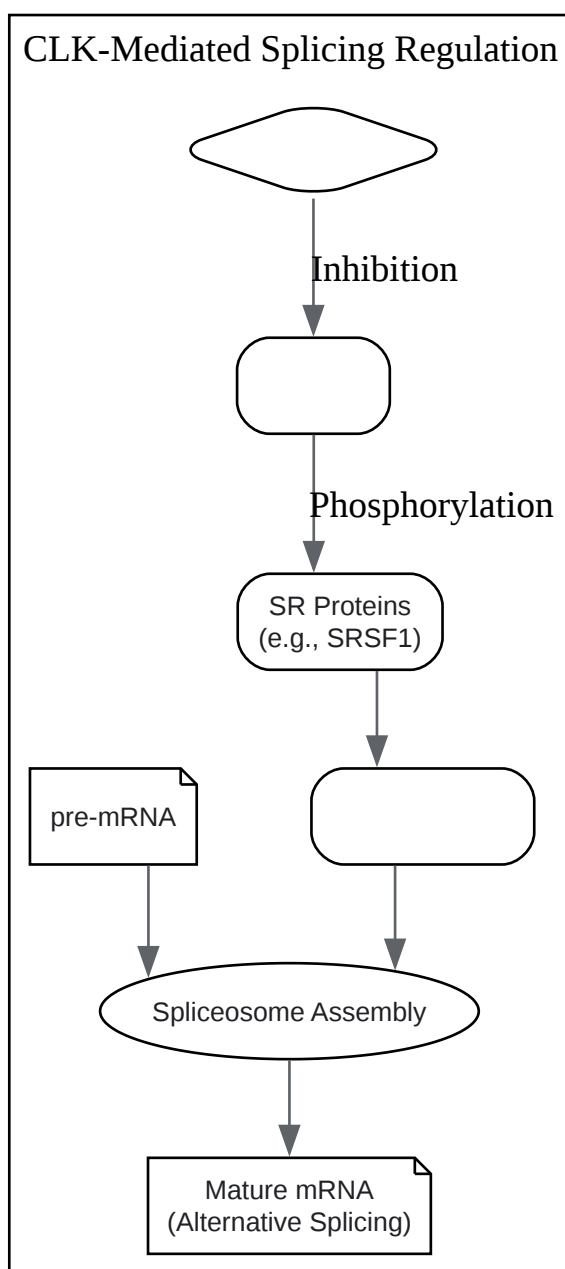

[Click to download full resolution via product page](#)

Caption: CLK Signaling Pathway Inhibition by **SRI-29329**.

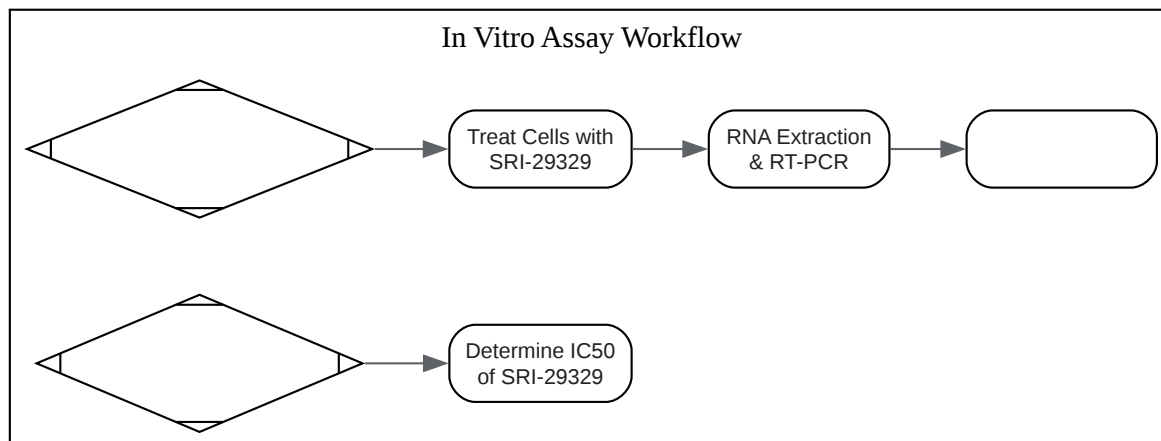

[Click to download full resolution via product page](#)

Caption: General workflow for in vitro evaluation of **SRI-29329**.

Experimental Protocols

In Vitro Kinase Inhibition Assay (ADP-Glo™ Format)

This protocol is adapted from commercially available kinase assay kits and is suitable for determining the IC₅₀ of **SRI-29329** against CLK1, CLK2, and CLK4.

Materials:

- Recombinant human CLK1, CLK2, or CLK4 enzyme
- Myelin Basic Protein (MBP) as a substrate
- **SRI-29329**
- ADP-Glo™ Kinase Assay Kit (Promega)
- Kinase Buffer (e.g., 40 mM Tris, pH 7.5, 20 mM MgCl₂, 0.1 mg/mL BSA)
- ATP

- DMSO
- White, opaque 96-well or 384-well plates

Procedure:

- **Compound Preparation:** Prepare a serial dilution of **SRI-29329** in DMSO. A typical starting concentration is 10 mM. Further dilute the compound in kinase buffer to achieve the desired final concentrations for the assay.
- **Reaction Setup:**
 - Add 5 μ L of kinase buffer containing the respective CLK enzyme to each well of the microplate.
 - Add 2.5 μ L of **SRI-29329** dilution or vehicle (DMSO) to the wells.
 - Add 2.5 μ L of a solution containing the substrate (MBP) and ATP. The final ATP concentration should be at or near the K_m for the specific CLK kinase.
- **Kinase Reaction:** Incubate the plate at 30°C for 60 minutes.
- **Assay Detection:**
 - Add 5 μ L of ADP-Glo™ Reagent to each well to stop the kinase reaction and deplete the remaining ATP. Incubate at room temperature for 40 minutes.
 - Add 10 μ L of Kinase Detection Reagent to each well to convert ADP to ATP and generate a luminescent signal. Incubate at room temperature for 30 minutes.
- **Data Acquisition:** Measure the luminescence using a plate reader.
- **Data Analysis:** Calculate the percent inhibition for each **SRI-29329** concentration relative to the vehicle control. Determine the IC50 value by fitting the data to a four-parameter logistic curve.

Cell-Based Alternative Splicing Assay (RT-PCR)

This protocol allows for the assessment of **SRI-29329**'s effect on the alternative splicing of a target gene in a cellular context.

Materials:

- A relevant cell line (e.g., HCT116, MDA-MB-468)
- Cell culture medium and supplements
- **SRI-29329**
- DMSO (vehicle control)
- RNA extraction kit (e.g., RNeasy Mini Kit, Qiagen)
- Reverse transcription reagents
- PCR reagents and primers flanking the alternative splicing event of a target gene (e.g., S6K)
- Agarose gel electrophoresis system

Procedure:

- Cell Culture and Treatment:
 - Seed cells in 6-well plates and allow them to adhere and grow to 70-80% confluency.
 - Treat the cells with various concentrations of **SRI-29329** or DMSO as a vehicle control. A typical treatment duration is 24 hours.
- RNA Extraction:
 - Following treatment, harvest the cells and extract total RNA using a commercial kit according to the manufacturer's instructions.
- Reverse Transcription (RT):
 - Synthesize cDNA from the extracted RNA using reverse transcriptase and random hexamers or oligo(dT) primers.

- Polymerase Chain Reaction (PCR):
 - Perform PCR using primers that flank the exon(s) subject to alternative splicing in a gene known to be regulated by CLKs (e.g., S6K).
 - The PCR conditions should be optimized for the specific primers and target. A typical protocol involves an initial denaturation step, followed by 25-35 cycles of denaturation, annealing, and extension, and a final extension step.
- Analysis of Splicing Variants:
 - Separate the PCR products on a 2% agarose gel.
 - Visualize the bands corresponding to the different splice variants (e.g., exon inclusion vs. exon skipping) using a gel documentation system.
 - Quantify the intensity of the bands to determine the relative abundance of each splice variant in response to **SRI-29329** treatment.
- To cite this document: [BenchChem. \[SRI-29329 In Vitro Assay: Application Notes and Protocols for Researchers\]. BenchChem, \[2026\]. \[Online PDF\]. Available at: \[https://www.benchchem.com/product/b10824542/docs#sri-29329-in-vitro-assay-application-notes-and-protocols-for-researchers\]](#)

Disclaimer & Data Validity:

The information provided in this document is for Research Use Only (RUO) and is strictly not intended for diagnostic or therapeutic procedures. While BenchChem strives to provide accurate protocols, we make no warranties, express or implied, regarding the fitness of this product for every specific experimental setup.

Technical Support: The protocols provided are for reference purposes. Unsure if this reagent suits your experiment?

Need Industrial/Bulk Grade? [Request Custom Synthesis Quote](#)

BenchChem

Our mission is to be the trusted global source of essential and advanced chemicals, empowering scientists and researchers to drive progress in science and industry.

Contact

Address: 3281 E Guasti Rd
Ontario, CA 91761, United States
Phone: (601) 213-4426
Email: info@benchchem.com

[Contact our Ph.D. Support Team for a compatibility check](#)