

# Navigating the Landscape of Casein Kinase Inhibition: A Comparative Guide

**Author:** BenchChem Technical Support Team. **Date:** April 2026

## Compound of Interest

Compound Name: CK156  
Cat. No.: B10824041

[Get Quote](#)

Initial investigations into the efficacy of a compound designated "**CK156**" as a Casein Kinase (CK) inhibitor have revealed no scientific literature or supplier information identifying it as such. The identifier "**CK156**" appears to be associated with unrelated commercial products. Therefore, this guide will focus on a comparative analysis of well-established and characterized inhibitors of the two primary families of Casein Kinases: Casein Kinase 1 (CK1) and Casein Kinase 2 (CK2).

This guide is intended for researchers, scientists, and drug development professionals, providing a comprehensive comparison of the efficacy of selected inhibitors for CK1 and CK2. The content includes quantitative data, detailed experimental methodologies, and visualizations of key signaling pathways and experimental workflows to facilitate a deeper understanding of these critical therapeutic targets.

## Casein Kinase Families: An Overview

Casein Kinases are a group of serine/threonine-selective protein kinases that play crucial roles in a multitude of cellular processes.<sup>[1]</sup> The two main families, CK1 and CK2, are implicated in distinct yet sometimes overlapping signaling pathways.

Casein Kinase 1 (CK1) is involved in the regulation of various cellular processes, including Wnt signaling, Hedgehog signaling, Hippo signaling, circadian rhythms, and DNA repair.[2][3][4] Dysregulation of CK1 activity has been linked to several types of cancer.

Casein Kinase 2 (CK2) is a highly pleiotropic kinase that phosphorylates a vast number of substrates, influencing pathways such as PI3K/AKT/mTOR, NF- $\kappa$ B, and JAK/STAT.[5][6] Its anti-apoptotic and pro-proliferative functions make it a prominent target in cancer therapy.[7][8]

## Comparative Efficacy of Selected CK1 and CK2 Inhibitors

To provide a clear comparison, we have selected two well-characterized inhibitors for each kinase family based on their potency and frequent use in research. For CK1, we will examine PF-670462 and D4476. For CK2, we will compare Silmitasertib (CX-4945) and TBB.

The following table summarizes the in vitro potency of these inhibitors, primarily focusing on their half-maximal inhibitory concentration (IC50) and binding affinity (Ki).

Inhibitor	Target Kinase Family	Specific Isoform(s)	IC50	Ki	Mechanism of Action
PF-670462	CK1	CK1ε, CK1δ	7.7 nM (CK1ε), 14 nM (CK1δ)[9][10]	Not widely reported	ATP-competitive
D4476	CK1	CK1	0.3 μM (300 nM)[11][12]	Not widely reported	ATP-competitive[1][2]
Silmitasertib (CX-4945)	CK2	CK2α, CK2α'	1 nM[9][13][14][15]	0.38 nM (CK2α)[13][16][17]	ATP-competitive[1][3][16]
TBB	CK2	CK2	0.15 μM (150 nM) for rat liver CK2[9][18][19], 0.9 μM - 1.6 μM for human recombinant CK2[20][21]	80 nM - 210 nM[20]	ATP/GTP-competitive[1][8][19][20]

## Signaling Pathways

The following diagrams illustrate the central roles of CK1 and CK2 in key signaling pathways.

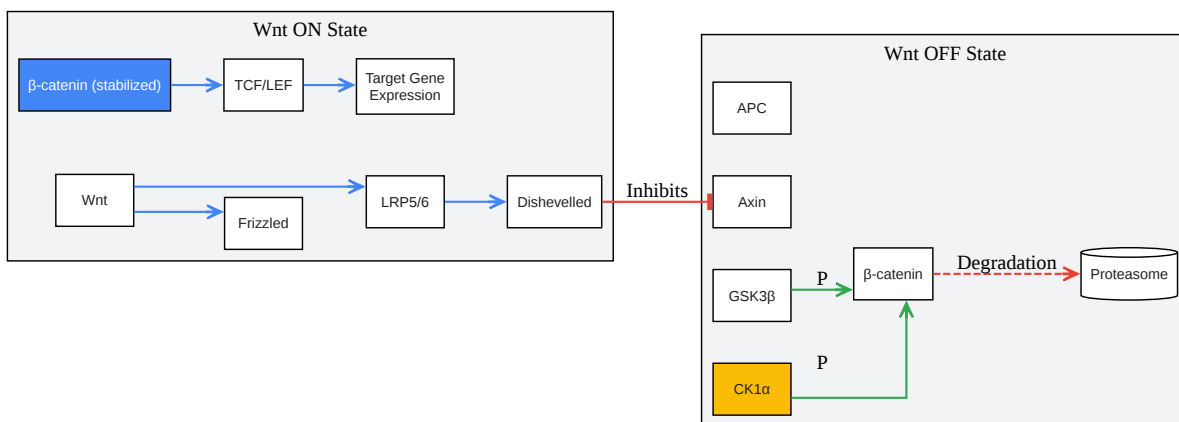

[Click to download full resolution via product page](#)

CK1 in the Wnt/ $\beta$ -catenin signaling pathway.

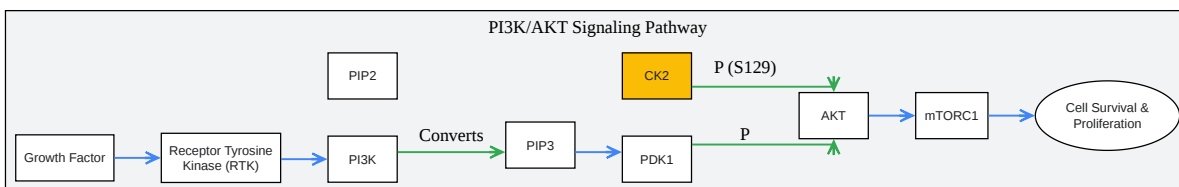

[Click to download full resolution via product page](#)

CK2 involvement in the PI3K/AKT signaling pathway.

## Experimental Protocols

The determination of IC<sub>50</sub> and K<sub>i</sub> values for kinase inhibitors is crucial for their characterization. A common method employed is a kinase inhibition assay. The following is a generalized protocol for such an assay.

**Objective:** To determine the concentration of a test compound that inhibits 50% of the kinase activity (IC<sub>50</sub>).

**Materials:**

- Purified recombinant kinase (e.g., CK1δ, CK2α)
- Kinase-specific substrate (peptide or protein)
- Test compound (inhibitor) at various concentrations
- ATP (adenosine triphosphate), often radiolabeled (e.g., [ $\gamma$ -<sup>33</sup>P]ATP) or a system to detect ADP production.
- Kinase reaction buffer (containing Mg<sup>2+</sup>)
- Phosphoric acid (to stop the reaction)
- Filter paper or other separation matrix
- Scintillation counter or luminescence plate reader

**Procedure:**

- Preparation of Reagents:
  - Prepare a stock solution of the test compound in a suitable solvent (e.g., DMSO).
  - Perform serial dilutions of the test compound to create a range of concentrations for testing.
  - Prepare a master mix containing the kinase reaction buffer, purified kinase, and substrate.
- Kinase Reaction:

- In a multi-well plate, add the serially diluted test compound to individual wells. Include a control well with solvent only (no inhibitor) and a blank well with no kinase.
- Initiate the kinase reaction by adding the master mix to each well.
- Start the phosphorylation reaction by adding ATP (e.g., [ $\gamma$ - $^{33}\text{P}$ ]ATP).
- Incubate the plate at a constant temperature (e.g., 30°C) for a specific period (e.g., 20-30 minutes), ensuring the reaction is in the linear range.
- Stopping the Reaction and Separation:
  - Terminate the reaction by adding a stopping reagent, such as phosphoric acid.
  - Spot an aliquot of the reaction mixture from each well onto a filter paper.
  - Wash the filter paper multiple times with a suitable buffer to remove unincorporated ATP, leaving only the phosphorylated substrate bound to the paper.
- Detection and Data Analysis:
  - Quantify the amount of phosphorylated substrate. For radiolabeled assays, this is done using a scintillation counter to measure radioactivity. For non-radioactive assays (e.g., ADP-Glo™), luminescence is measured.[\[22\]](#)
  - Plot the percentage of kinase inhibition versus the logarithm of the inhibitor concentration.
  - Fit the data to a sigmoidal dose-response curve to determine the IC50 value.

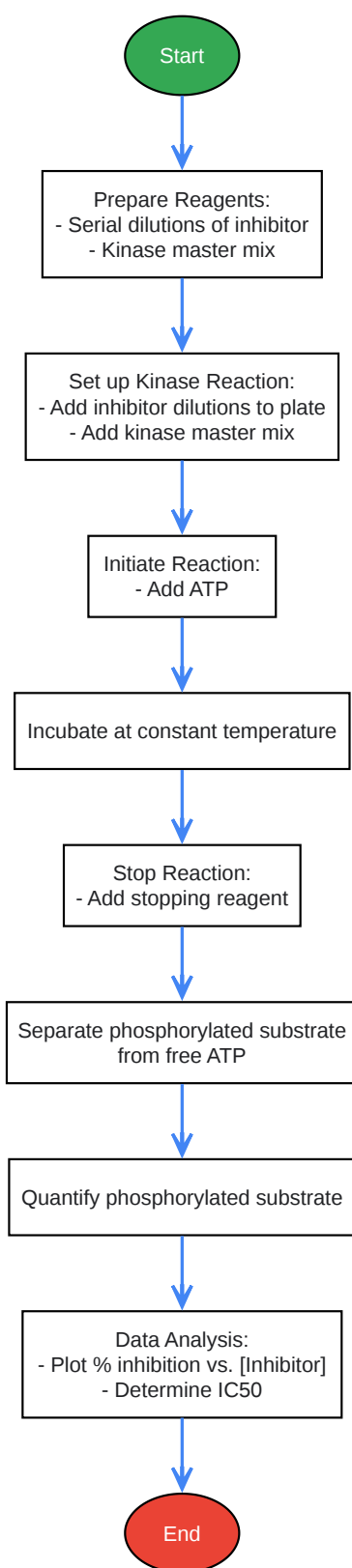

[Click to download full resolution via product page](#)

General workflow for a kinase inhibition assay.

### Need Custom Synthesis?

BenchChem offers custom synthesis for rare earth carbides and specific isotopic labeling.

Email: [info@benchchem.com](mailto:info@benchchem.com) or [Request Quote Online](#).

## References

- [1. Casein kinase 1 - Wikipedia \[en.wikipedia.org\]](#)
- [2. CK1: Casein kinase 1 - Creative Enzymes \[creative-enzymes.com\]](#)
- [3. The Role of the Casein Kinase 1 \(CK1\) Family in Different Signaling Pathways Linked to Cancer Development | Semantic Scholar \[semanticscholar.org\]](#)
- [4. CK1 in Developmental signaling: Hedgehog and Wnt - PMC \[pmc.ncbi.nlm.nih.gov\]](#)
- [5. researchgate.net \[researchgate.net\]](#)
- [6. researchgate.net \[researchgate.net\]](#)
- [7. Casein Kinase 2 Signaling in White Matter Stroke - PMC \[pmc.ncbi.nlm.nih.gov\]](#)
- [8. journals.asm.org \[journals.asm.org\]](#)
- [9. medchemexpress.com \[medchemexpress.com\]](#)
- [10. Casein Kinase compound \(inhibitors, antagonists\)-ProbeChem.com \[probechem.com\]](#)
- [11. D4476 | Apoptosis | Casein Kinase | Autophagy | ALK | TargetMol \[targetmol.com\]](#)
- [12. medchemexpress.com \[medchemexpress.com\]](#)
- [13. selleckchem.com \[selleckchem.com\]](#)
- [14. medchemexpress.com \[medchemexpress.com\]](#)
- [15. ZFIN ChEBI: CX-4945 \[zfin.org\]](#)
- [16. cellagentech.com \[cellagentech.com\]](#)
- [17. Silmitasertib \(CX4945\) | CK2 \$\alpha\$  inhibitor | Probechem Biochemicals \[probechem.com\]](#)
- [18. TBB - tcsc1079 - Taiclone \[taiclone.com\]](#)
- [19. medchemexpress.com \[medchemexpress.com\]](#)
- [20. TBB | Casein Kinase 2 | Tocris Bioscience \[toocris.com\]](#)
- [21. TBB | GSK-3 | Casein Kinase | CDK | TargetMol \[targetmol.com\]](#)
- [22. ulab360.com \[ulab360.com\]](#)

- To cite this document: BenchChem. [Navigating the Landscape of Casein Kinase Inhibition: A Comparative Guide]. BenchChem, [2026]. [Online PDF]. Available at: [<https://www.benchchem.com/product/b10824041/docs#navigating-the-landscape-of-casein-kinase-inhibition-a-comparative-guide>]

---

### Disclaimer & Data Validity:

The information provided in this document is for Research Use Only (RUO) and is strictly not intended for diagnostic or therapeutic procedures. While BenchChem strives to provide accurate protocols, we make no warranties, express or implied, regarding the fitness of this product for every specific experimental setup.

**Technical Support:** The protocols provided are for reference purposes. Unsure if this reagent suits your experiment?

**Need Industrial/Bulk Grade?** [Request Custom Synthesis Quote](#)

## BenchChem

Our mission is to be the trusted global source of essential and advanced chemicals, empowering scientists and researchers to drive progress in science and industry.

### Contact

Address: 3281 E Guasti Rd  
Ontario, CA 91761, United States  
Phone: (601) 213-4426  
Email: [info@benchchem.com](mailto:info@benchchem.com)

[Contact our Ph.D. Support Team for a compatibility check](#)